

Instruction Manual
For
Model B2F, B3 Center-Flue System
Boiler and Burner

Saito Seisakusho Co., Ltd.
22-7, Tokagi 3-chome
Ichikawa city, Chiba pref. 272-0024
Japan

The description should be started with our gratitude for your patronage of our products. Mainly aiming at installation on board, our products are designed and manufactured taking compactness, high efficiency, easy handling and safety into full consideration. They can be said to provide "Best Matching" with our steam engines and boat kits.

Features

1. Center Flue System

Although various boiler heating manners are available, types commonly use for models are shown below.

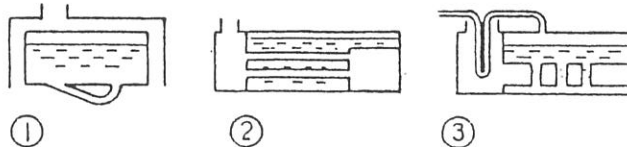

Features of the 3 types can be compared with each other as follows:-

- ① Smith Type -The boiler construction is rather simple but because of the under heating system, the height comes to larger and a cover is needed in order to exhaust waste gas, resulting in increased size due its heat insulation required and in poor thermal efficiency.
- ② Smoke Tube Type -This type is used for steam locomotives. It provides good thermal efficiency, however, the construction is somewhat complicated to difficulty of making in compact.
- ③ Center Flue Type -This type allows considerably simple construction with good ventilation of waste gas. The combustion chamber is surrounded by water and this provides good thermal efficiency in cooperation with the penetrating water tubes. Accordingly, it can be said the most suitable for model.

2. Super Heater (Superheated Tube)

The steam (Saturated steam) taken out of the regulator valve is again sent back to the combustion chamber to heat and made into dry steam. Compared with the original steam, this steam has high energy provided with various advantages.

3. Burner

This burner is a type of injecting combustion system where alcohol is preheated, gasified and burnt provided with high and stable heating power based on our development, the burner is easy and safe in handling.

Functions and Particulars

<u>Model</u>	<u>B2F</u>	<u>B3</u>
<u>BOILER</u>		
Type	Center Flue System	
Boiler Capacity	400 c.c.	500 c.c.
Normal Pressure	1.5 - 2.0 kg/CM2	
Safety Valve Working Pressure	2 kg/CM2 approx.	
Number Safety Valve	2	
Regulator Valve	Lever type attached with a whistle nozzle	
Attached Equipment	Superheaters Smoke Emitting Equipment	
<u>BURNER</u>		
Type	Alcohol-injecting combustion system	
Applicable Fuel	Methanol (Or Fuel Alcohol)	
Tank Capacity	100 scales of attached cup	140 scales of attached cup
Burning Time	20 minutes approx.	
Normal Pressure	0.4 kg/CM2 approx.	
Safety Valve Working Pressure	1.5 kg/CM2 approx.	
Dimension	300 x 75 x 120 m/m L. W. H.	350 x 75 x 120 m/m L. W. H.
Weight	1,260 gram	1,600 gram
Adaptable Engine	T2DR and T3DR	T2DR and T3DR
Adaptable Hull	1 - 1.3 meter (Hercules, Kamome and Polar Star)	1.2 - 1.4 meter (Kamome, Polar Star and Chiba Star)

B2F, B3 Part Drawing

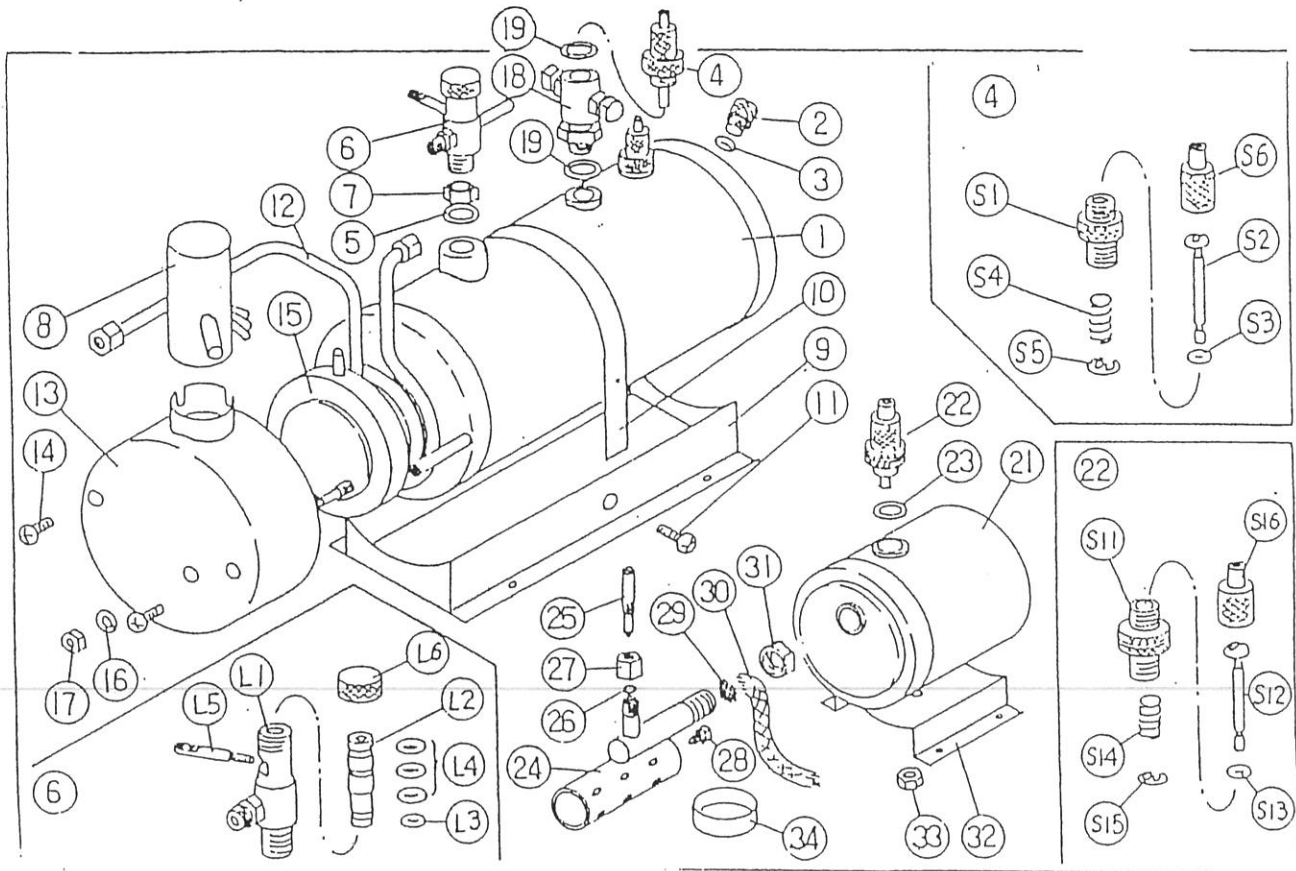

(18) & (19) of B2F should be mounted onto the safety valve pads on the burner side.

(4) Boiler Safety Valve

(6) Regulator Valve

(22) Burner Safety Valve

Installation and Piping

Refer to the figure below. For installation on board of our hull, see the drawing in the kit.

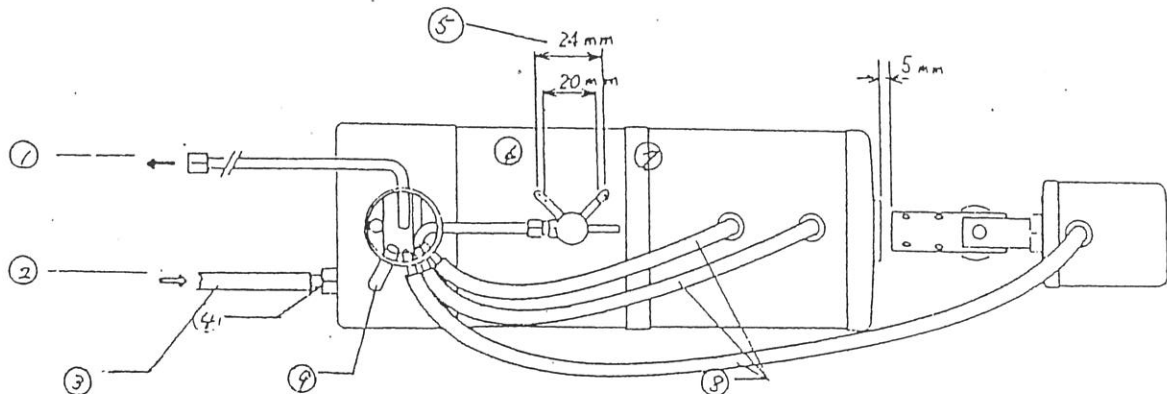

- (1) To engine feeding steam.
- (2) From engine exhaust.
- (3) 2.3m/m Neoprene Tube
- (4) Smoking Device
- (5) Stroke
- (6) Open
- (7) Close
- (8) 2.3m/m Neoprene Tube
- (9) Discharging from drain tank

Boiler Part List

No.	Name	Q'ty	No.	Name	Q'ty
1	Boiler Body	1	2	WATER level inspection hole plug	1
3	"O" Ring P3	1	4	Safety Valve	2
5	"O" Ring P6	1	6	Regulator Valve	1
7	Lock Nut	1	8	Funnel	1
9	Boiler Base	1	10	Boiler Band	1
11	Machine Screw M3	1	12	Superheated Tube	1
13	Smoke Chamber	1	14	Smoke Chamber Fitting Machine Screw	2
15	Smoke Emitting Device	1	16	Washer	1
17	Nut	1	18	Pressure Gauge Adaptor	1
19	"O" Ring P6	3	(6)	<u>Regulator Valve Parts</u>	
(4)	<u>Safety Valve Parts for 2 sets</u>		L1	Valve Body	1
S1	Valve Body	2	L2	" Piece	1
S2	Stem	2	L3	"O" Ring P2	1
S3	"O" Ring P2	2	L4	" " P3	3
S4	Spring	2	L5	Lever	1
S5	"E" Ring	2	L6	Cap	1
S6	Cover	2			

Burner Part List

21	Tank	1	32	Burner Base	1
22	Safety Valve	1	33	Nut	1
23	"O" Ring P6	1	34	Preheating plate	1
24	Combustion Cylinder	1			
25	Needle Valve	1	(22)	<u>Safety Valve Parts</u>	
26	Ground Packing	1	S11	Valve Body	1
27	" Nut	1	S12	Stem	1
28	Plug	1	S13	"O" Ring P2	1
29	Filter	1	S14	Spring	1
30	Suction String	1	S15	"E" Ring	1
31	Lock Nut	1	S16	Cover	1

Operation

Follow the procedure in order of water (Boiler water supplying), oil (Lubrication for engine, etc.) and alcohol (Burner fuel oil supplying) to prevent the burner from empty burning.

1. Boiler Water Supplying

Remove the water level inspection hole plug and the safety valve, place the boiler roughly horizontal and fill the boiler with water until it overflows through the safety valve seat hole and the water level inspection hole. Water volume is to be about 400 c.c. for B2F and about 500 c.c. for B3. After completion of supplying water, attach the plug and safety valve to the boiler.

2. Burner Fuel Oil Supplying

After removing the safety valve, fill the burner with methanol (Or fuel alcohol) by 100 scales for B2F and 140 scales for B3 by means of the attached cup and mount the safety valve. (Do not use gasoline, thinner or kerosene).

3. Inspection

Prior to ignition, the following matters should be checked:-

- 1 That the needle valve of the burner is closed.
- 2 That the safety valve of the burner is correctly mounted and operates normally.
- 3 That the safety valve of the boiler is correctly mounted and operates normally.
- 4 That the water level inspection hole plug of the boiler is correctly fitted.
- 5 That the regulator valve of the boiler is closed.

4. Preheating of Burner

Pour about 5 - 6 c.c. (As much as two fillers attached) of methanol into the preheating plate and ignite it. The volume should be somewhat increased under the cold weather in winter. In windy outdoors, hold the flame sufficiently touching the combustion cylinder by means of a windbreak.

5. Ignition on Burner

Ignition should be made slowly opening the needle valve at a point as the fuel in the preheating plate is being burnt out. If the flame in the preheating plate has gone out before ignition, make ignition directly on the burner by means of a match or the like. Perfect ignition can be confirmed by blue flame accompanied by continuous combustion sound "bahh-----".

6. Adjustment of Needle Valve

After ignition achieved, go on gradual opening the needle valve, keeping the burner at a stable burning state to increase heating power.

Stop operating the valve under a condition where the heating power comes to showing no increment even if further opening the valve (the maximum heating power). The valve opening at this point is equivalent to a quarter turn. Rapid opening of the needle valve will cause unstable burning or sometimes flame going out.

7. Steam-up (Steam is ready to output)

Time required for boiler pressure to rise to 1.5 -2.0 kg/CM² is about 3 - 4 minutes for both B2F and B3, however, there would be some variation according to seasonal reason such as winter or to condition of a burner.

8. Operation of Regulator Valve

The lever turned to the left (Counter-clockwise) will open and that to the right will close, the regulator valve. It is so arranged that steam also emits out of the whistle nozzle over a range between a point a little before the full open and a point of the full open.

Adjustment and Maintenance

1. Care for Safety Valve

At every water and lubricating oil supply, make sure of the operation of valve by applying several motions. Fur and dust, if any, should be eliminated. Replace "O" Rings, if excessively deformed (Roughly round in the section in new one), lost of elasticity, injured or cracked. If practicable, inspection by means of a pressure gauge will be the best way.

Note: The safety valve working pressure is about 2.0 kg/CM² for boiler and about 1.5 kg/CM² for burner. The body of safety valve for burner is red painted for identification. As for the safety valve, it is advised not to make remodelling, especially to increase the rated working pressure.

2. Care for Burner

The function of boiler definitely depends on how to adjust and maintain the burner. At every several runnings, eliminate oxidized substances from the nozzle portion by use of a cleaning pin attached.

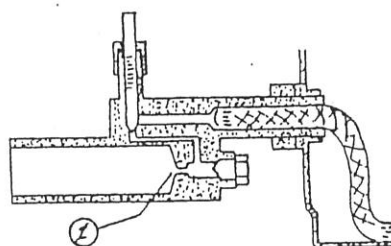

① Nozzle portion

Optional Accessories

Pressure Gauge (Attached with a fitting and piping), Smoke Tank (Attached with piping)

Common Troubles on Burner and Remedies

<u>Condition</u>	<u>Cause</u>	<u>Remedy</u>
No gas emitting	No fuel	Replenish fuel
	Chocked combustion cylinder nozzle	Eliminate oxidized substances by putting a cleaning pin through.
Emitting of green gas (Misty, Liquid)	Insufficient pre-heating	Again, perform preheating.
Unstable burning (Fire goes out in the course of running)	Excessive needle valve opening ($\frac{1}{4}$ turn at Maximum)	Throttle needle valve. Otherwise, clean nozzle.
	Excessive preheating	First throttle needle valve.
	If happened from the beginning.	After a while watching burning condition, gradually open needle valve.
	If happened in the course of running.	When installed on board, a poor ventilation within a boat forces a temperature surrounding burner to rise, resulting in overheated fuel tank. (For own make hulls in particular, attention is required). Better ventilation is required.
Weak heating power	Fuel mixed with water	Exchange fuel oil
	Chocked nozzle of combustion cylinder	Eliminate oxidized substances by putting a cleaning pin through.
	Poor suction of fuel by the suction string	Remove safety valve, put a bar in to it and make the suction string reach the tank bottom. (See the section drawing in the previous page)
No pressure rise	Weak heating power of burner	Refer to "Common Troubles on Burner and Remedies"
	Leak from safety valve	Eliminate fur, dust, etc. Otherwise, exchange O rings.
	Leak from regulator valve	- ditto -
	Leak through safety valve seat, regulator valve seat or water level inspection hole	Replace packings (O Rings)

B2F.B3

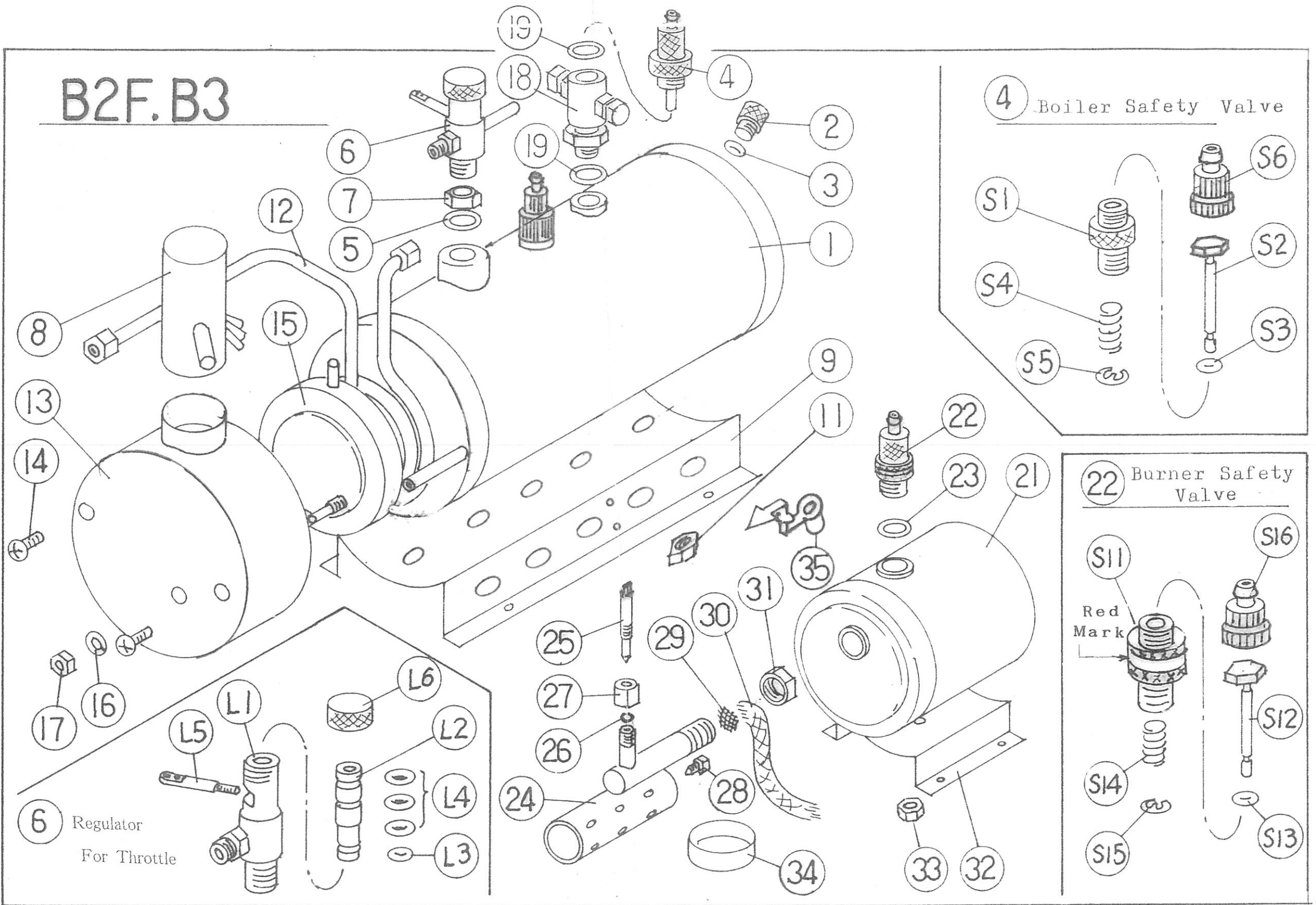

B2F. B3 Parts List

NO		Description	Q' ty	NO		Description	Q' ty
1		Boiler Body	1	16		Washer	1
2		Outlet For Overflow Plug	1	17		Nut	1
3		O-Ring 「P-3」	1	18		Adopter For Pressure Gauge	1
4		Safety Valve For Boiler	2	19		O-Ring 「P-6」	3
	S 1	Safety Valve Body	2	21		Alcohol Tank For Burner	1
	S 2	Stem	2	22		Safety Valve For Burner	2
	S 3	O-Ring 「P-2」	2		S11	Safety Valve Body	1
	S 4	Spring	2		S12	Stem	1
	S 5	E-Ring	2		S13	O-Ring 「P-2」	1
	S 6	Cover	2		S14	Spring	1
5		O-Ring 「P-6」	1		S15	E-Ring	1
6		Regulator Complete	1		S16	Cover	1
	L 1	Regulator Body	1	23		O-Ring 「P-6」	1
	L 2	Valve	1	24		Combustion Cylinder	1
	L 3	O-Ring 「P-2」	1	25		Needle Valve	1
	L 4	O-Ring 「P-3」	3	26		Gland Packing	3
	L 5	Lever	1	27		Gland Nut	1
	L 6	Cap	1	28		Plug	1
7		Lock Nut For Regulator	1	29		Filter	1
8		Funnel	1	30		Suction String	1
9		Boiler Mount	1	31		Lock Nut	1
11		Fixed Nut For Boiler Mount	2	32		Burner Mount	1
12		Superheated Tube	1	33		Fixed Nut For Burner Mount	1
13		Smoke Chamber	1	34		Heating Tray	1
14		Smoke Chamber Fitting Screw	2	35		Indicator	1
15		Smoke Emitting Device	1				