

# TRAXXAS



## ATON

MODEL 7908

## ATON+

MODEL 7909

**OWNER'S MANUAL**  
**MANUEL DU PROPRIÉTAIRE**  
**MANUAL DEL USUARIO**  
**BEDIENUNGSANLEITUNG**

## CONTENTS

INTRODUCTION.....	2
INCLUDED SUPPORT EQUIPMENT.....	2
MODEL ORIENTATION.....	2
KNOW BEFORE YOU FLY.....	3
FLIGHT CONTROLS.....	4
SAFETY PRECAUTIONS.....	5
PREPARING FOR FLIGHT.....	6
FLYING YOUR MODEL.....	7

AUTO TAKE-OFF.....	7
RETURN TO HOME.....	7
FLIGHT MODES.....	10
FILM MODE.....	10
SPORT MODE.....	11
EXPERT MODE.....	12
CARING FOR YOUR HELICOPTER.....	12
ROTOR BLADE INSTALLATION.....	12
TROUBLESHOOTING GUIDE.....	13

All instructions and precautions outlined in this manual should be strictly followed to ensure safe operation of your model. Failure to comply with the warnings, instructions, and precautions in this manual could lead to product damage and personal injury.

## INTRODUCTION

Thank you for purchasing the Traxxas Aton quad rotor high performance helicopter. This manual contains the instructions you will need to operate and maintain your model. Even if you are an experienced R/C enthusiast, it's important to read and follow the procedures in this manual so that you are fully knowledgeable on the operation and care of your Aton. We want you to feel confident that you own one of the best-performing models in the market and that it is backed by a team of professionals who aim to provide the highest level of factory support possible. Our Customer Support team is with you every step of the way. If you have any questions about your model or its operation, call the Traxxas Technical Support Line toll-free at: 1-888-TRAXXAS (1-888-872-9927) (Toll-free support is available to U.S. residents only).

## QUICK START GUIDE

See the included Quick Start Guide for initial setup of your helicopter. The Quick Start Guide is not intended to replace the full operating instructions available in this manual. Please read this entire manual to become familiar with the controls and operations of the model before attempting to fly it the first time.

## INCLUDED SUPPORT EQUIPMENT

- High capacity LiPo iD battery
- LiPo battery charger with AC power cord
- 4 Traxxas AAA alkaline batteries
- Landing gear with hardware
- Camera mounting bracket with hardware (designed for use with GoPro® action cameras\*)
- 2mm hex wrench (to assist with repairs)
- Spare rotor blade set
- Spare hardware
- Transmitter sticks (interchangeable with the thumb pads)

## MODEL ORIENTATION

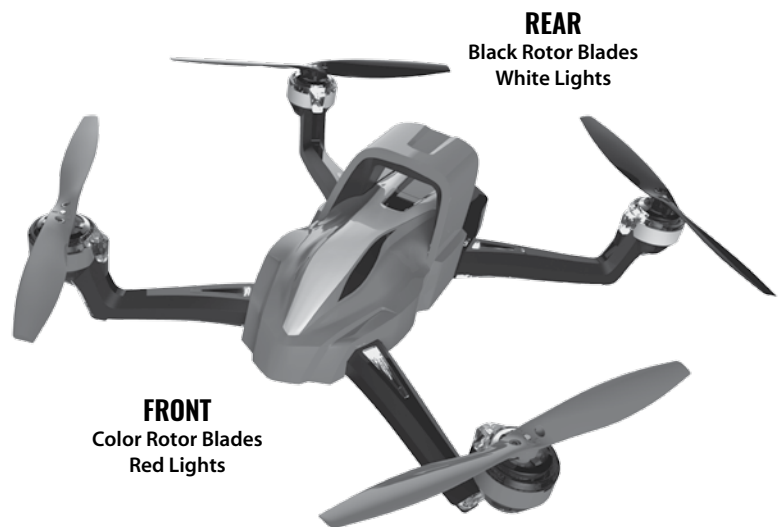

\*Camera not included



## KNOW BEFORE YOU FLY

Welcome to the world of fun and excitement with model aviation. The Åton is designed for the purpose of easily capturing beautiful and exciting imagery or to explore the freedom of flight just for the fun of it. The included Quick Start Guide contains an overview of the operation of the Åton and the steps you need to take to get flying quickly. We recommend that you review both the Quick Start Guide and this full Owner's Manual so that you are fully knowledgeable on the operation and care of your Åton. This will help you maintain and enjoy the model for years to come. Traxxas support is always available to answer your questions and help you with any issues you may encounter. Our contact information is on the previous page.

The Åton is a high performance model that has tremendous power and capability. With that comes the responsibility to read, understand, and follow all warnings, precautions, and instructions to ensure the safe operation of the model. Failure to operate the model in a safe and responsible manner may result in property damage and serious injury to yourself and others. **As the pilot, you alone are responsible for ensuring that all instructions and precautions are adhered to.**

### Your Important Responsibility as a Pilot

The Åton must operate in shared air space with other model aircraft and more importantly, full-sized aircraft. It is critically important to choose a flying/filming location that meets the rules and regulations that have been established by local and national regulating bodies so that you will not create a hazard for any other aircraft in flight or person on the ground.

### Where Can I Fly:

Choose a location that offers plenty of open space, away from people. Your Åton is controlled by radio which is subject to interference from sources beyond your control. Fly in locations that minimize any possible risk to people or property if you somehow lose control of your model.

1. Some areas such as parks or schools may be restricted for operation of radio control models. Look for posted signs or check with local authorities.
2. Look for natural or man-made obstacles that can interfere with your flight or block your line of sight to the model. Examples include:
  - Tree lines
  - Power lines
  - Buildings
  - Light poles
  - Water towers
3. You must be able to maintain line of sight to your model at all times during flight.

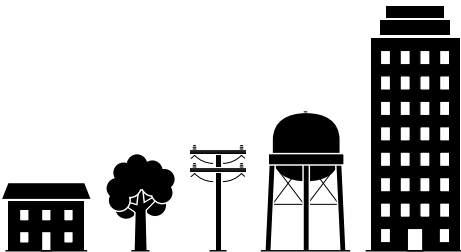

### Places You Should Not Fly:

The Federal Aviation Administration (FAA) governs the use of US airspace. The FAA classifies the Åton as an unmanned aircraft system (UAS) and RC model pilots are expected to comply with FAA regulations and restrictions for UASs.

- **Do Not Fly** over roads or highways where your model could disrupt or distract passing traffic.
- **Do Not Fly** within a 5-mile radius of an airport without first contacting the tower or airport authorities.
- **Do Not Interfere** with manned aircraft operations, and you must see and avoid other aircraft and obstacles at all times. If you are able to

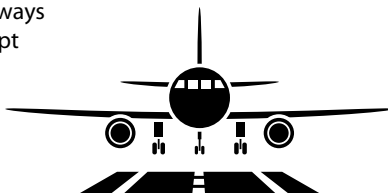

fly near manned aircraft then it is likely you are flying in a restricted area. Land immediately and find another location.

- **Do Not Fly** in areas with temporary flight restrictions. Examples of temporary flight restrictions include but are not limited to:

- Sports stadiums and other similar venues
- Racetracks
- Disaster and hazard areas (such as fires or traffic accidents)
- Large public gatherings

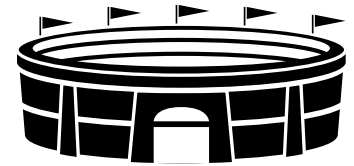

- **Consult** with local airport officials to determine if there are flight restrictions where you intend to fly.

- **Do Not Fly** near or over sensitive infrastructure or property such as power stations, water treatment facilities, correctional facilities, heavily traveled roadways, government facilities, etc.

- **Limit** your altitude to 400 feet (122 meters) maximum.

- **Check and Follow** all local laws and ordinances before flying or filming over private property.

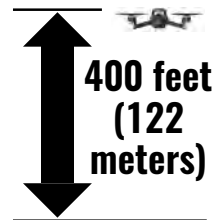

### Safety for Everyone

- **Do Not Fly** while impaired by any substance or physical ailment.
- **Do Not** intentionally fly over unprotected persons or moving vehicles, and remain at least 25 feet (7.5 meters) away from individuals and vulnerable property.
- **Do Not Fly** in adverse weather conditions such as in high winds or reduced visibility.
- **Keep** your model in sight at all times.
- **Do Not** conduct surveillance or photograph persons in areas where there is an expectation of privacy without the individual's permission.
- **Maintain** your model to prevent mechanical problems.
- **Do Not Attempt** to rescue your model in dangerous areas or conditions. If the model does get tangled in trees, power lines, or lands on rooftops, in water, and so on, do not risk personal injury or death to yourself or others attempting to retrieve the model.
- **Know How** to disarm your model. If a bystander approaches the model while in operation, land and disarm immediately to prevent injury. Spinning props are dangerous. Keep spectators and bystanders well clear of the model while in operation.

### Who is Know Before You Fly?

Know Before You Fly is an education campaign founded by the Association for Unmanned Vehicle Systems International (AUVSI), the Academy of Model Aeronautics (AMA), and the Small UAV Coalition in partnership with the Federal Aviation Administration (FAA) to educate prospective users about the safe and responsible operation of unmanned aircraft systems (UAS). At the Know Before You Fly website you will find additional information and useful links to learn even more about safe flying. For more information visit [www.knowbeforeyoufly.org](http://www.knowbeforeyoufly.org)

### No Commercial Use

The Åton is intended for personal recreational use. At the time this publication was created, the FAA requires anyone using an unmanned aircraft system for non-hobby purposes to acquire authorization from the FAA. Non-hobby purposes include but are not limited to commercial activities such as for-hire film and photography services, real estate and wedding photography, commercial film and television production, and for-hire inspection and survey services. For more information on what types of activities constitute non-hobby use and how to obtain authorizations and exemptions, visit [www.faa.gov/uas](http://www.faa.gov/uas).

For operation outside of the US, be sure to consult regulations specific to your country and/or local region..

### Pre-Flight Checklist

- Read all manufacturer supplied instructions and precautions before attempting to operate the model.
- Make sure that you as a pilot are competent and proficient in the operation of your model. It is important to become familiar with the controls and operations of the model before attempting to operate it the first time.
- Make sure that your batteries are charged and the model is fully operational. Do not operate a damaged or malfunctioning model.
- Make sure you have a GPS satellite signal.
- Make sure the operating environment is safe.

### Controls (Mode 2 Operation)

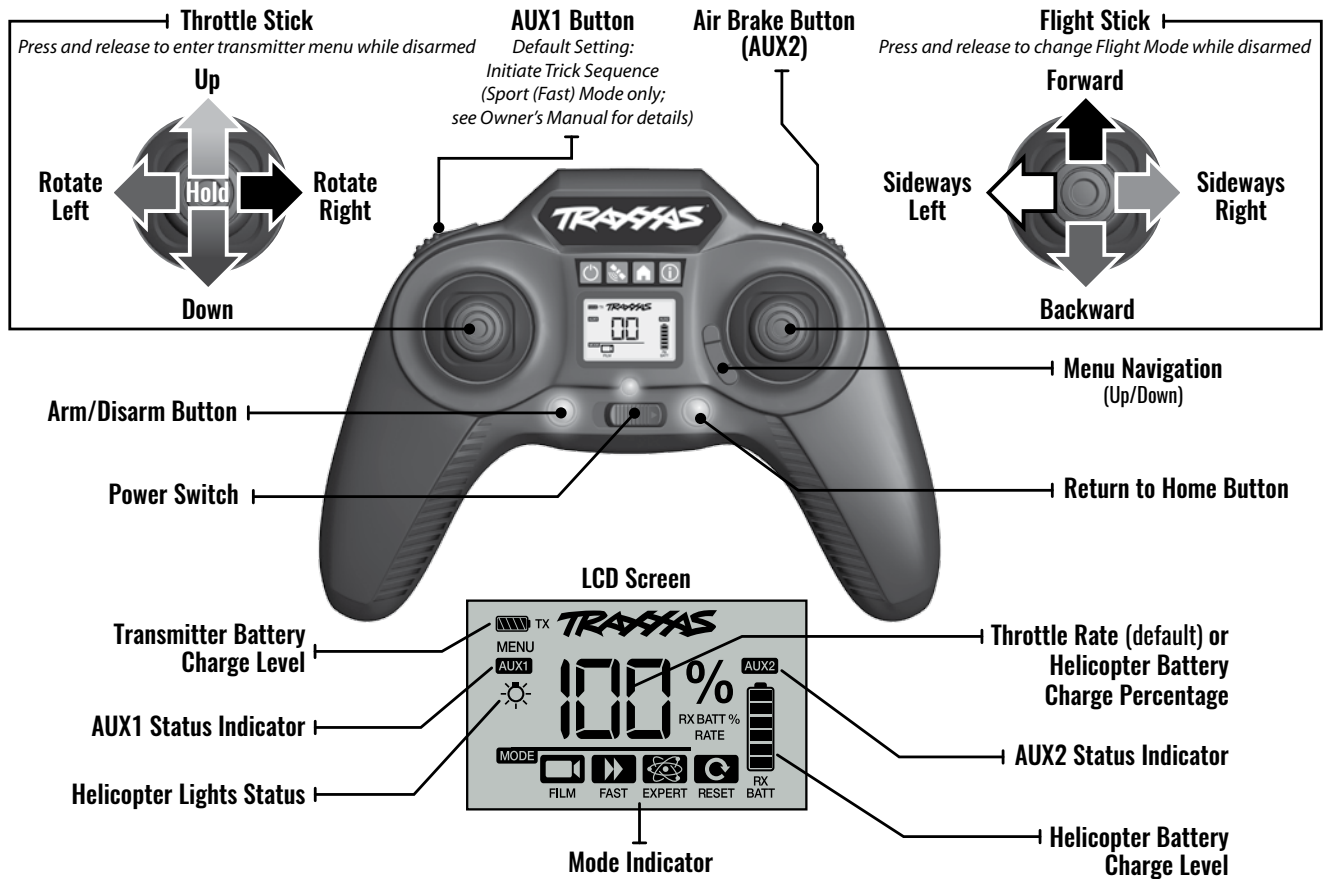
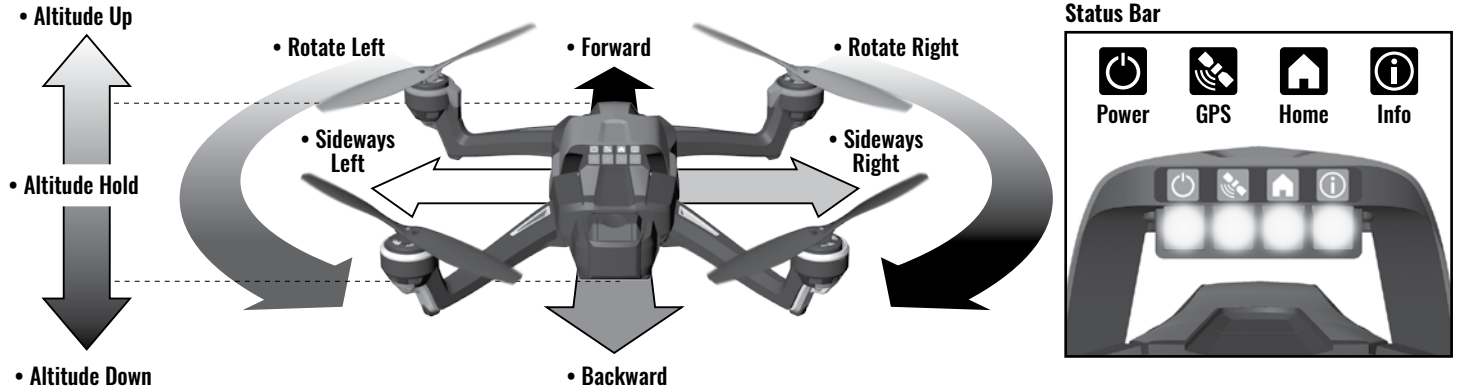



## SAFETY PRECAUTIONS

- Never fly the helicopter with low batteries. Low battery indicators include:
  - The transmitter or the receiver battery level indicator on the transmitter LCD starts flashing, and the transmitter starts beeping continuously.
  - The rear-facing green *Info* Status LED on the helicopter is flashing.
  - The helicopter loses power and lands itself (low voltage cutoff).
  - Alert tones from the transmitter.
  - Automatic return to home.
- The helicopter has rotating blades that move at high speed, posing danger of damage and injury. Pilots are responsible for any actions that result in damage or injury from the improper operation of the helicopter. Choose an adequate flying space without obstacles. Do not operate the helicopter near buildings, crowds of people, high-voltage power lines, or trees to ensure the safety of yourself, others, and your model. Wear eye protection when operating your helicopter and keep your hands, face, hair, loose clothing, and foreign objects away from the rotating blades.
- This model has small parts that may pose a choking hazard. Keep all small parts and electrical devices out of the reach of children and animals.
- Pets can become excited by radio-controlled models. Keep pets away from your model at all times.
- Your *Åton* is controlled by radio which is subject to interference from sources beyond your control. Radio interference can cause momentary losses of radio control; always allow a safety margin in all directions around the model to prevent collisions.
- Do not attempt to rescue your model in dangerous areas or conditions. If the model does get tangled in trees, power lines, or lands on rooftops, in water, and so on, do not risk personal injury or death to yourself or others attempting to retrieve the model.
- Do not fly while impaired by any substance or physical ailment.
- Moisture causes damage to electronics. Avoid exposing your model, transmitter, and battery to water.
- The motor, batteries, and speed control can become hot during use. Allow parts to cool before handling.
- Do not leave the model unattended while it is turned on. Immediately turn the model and the transmitter off after you have safely landed the model.
- **Most importantly, use good common sense at all times.**

**TERMS OF USE** - The buyer assumes all risk associated with using this product. Traxxas, its affiliates, manufacturers, distributors, and retail partners cannot control the use, application, charging or installation of this product and shall not be held responsible for any accident, injury to persons, or damage to property resulting from the use of this product.

After reading all, if you do not agree with these terms and conditions and are not prepared to accept complete liability for the use of this product, return this product immediately in new/unused condition to your place of purchase. Your retailer absolutely cannot accept product for return or exchange if it has been used in any way.

If you have any questions, call Traxxas Customer Support at 1-888-TRAXXAS (1-888-872-9927). Outside the US, call +1-972-549-3000 or e-mail support@traxxas.com.

## WARNING! CAUTION! DANGER!



**FIRE HAZARD!** Charging and discharging batteries has the potential for fire, explosion, serious injury, and property damage if not performed per the instructions. In addition, Lithium Polymer (LiPo) batteries pose a SEVERE risk of fire if not properly handled per the instructions and require special care and handling procedures for long life and safe operation. **WARNING:** LiPo batteries are intended only for advanced users that are educated on the risks associated with LiPo battery use. Traxxas does not recommend that anyone under the age of 14 use or handle LiPo battery packs without the supervision of a knowledgeable and responsible adult. Dispose of used batteries according to the instructions.

- Your model requires the use of LiPo batteries. LiPo batteries have a minimum safe discharge voltage threshold that should not be exceeded. The Traxxas *Åton* is equipped with built-in Low-Voltage Detection that alerts the pilot when LiPo batteries have reached their minimum voltage (discharge) threshold. It is the pilot's responsibility to stop immediately to prevent the battery pack from being discharged below its safe minimum threshold.
- Low-Voltage Detection is just one part of a comprehensive plan for safe LiPo battery use. It is critical to follow all instructions for safe and proper charging, use, and storage of LiPo batteries. Make sure you understand how to use your LiPo batteries. If you have questions about LiPo battery usage, please consult with your local hobby dealer or contact the battery manufacturer. As a reminder, all batteries should be recycled at the end of their useful life.
- The included LiPo battery pack must be charged ONLY with a Lithium Polymer (LiPo) balance charger, such as the included LiPo balance charger, the Traxxas EZ-Peak Plus, part #2970, or the Traxxas EZ-Peak Dual, part #2972. Only use a LiPo charger compatible with Traxxas iD batteries. If you are using a LiPo balance charger that is not compatible with Traxxas iD batteries, the Traxxas balance adapter (part #2938) is required.
- DO NOT use a charger designed for NiMH or NiCad batteries. Failure to use the correct charger may result in battery damage, fire, personal injury, and/or property damage.
- The use of a NiMH or NiCad charger or charge mode will damage the batteries and may cause fire and personal injury.
- ALWAYS inspect your LiPo batteries carefully before charging. Do not use or charge battery packs that have been damaged in any way (bent, dented, swollen, torn covering, or otherwise damaged).
- DO NOT remove or change the connector on Traxxas iD batteries. Changing the connector could remove the ability to balance charge the battery pack.
- BEFORE you charge, ALWAYS confirm that the charger settings exactly match the type (chemistry), specification, and configuration of the battery to be charged. DO NOT exceed the maximum manufacturer recommended charge rate. DO NOT attempt to charge non-rechargeable batteries (explosion hazard), batteries that have an internal charge circuit or a protection circuit, or batteries that have been altered from original manufacturer configuration.
- While charging or discharging, ALWAYS place the battery (all types of batteries) in a fire retardant/fire proof container and on a non-flammable surface such as concrete.
- ALWAYS charge batteries in a well-ventilated area.
- Charge the battery in a safe area away from flammable materials. Monitor the charging process and never leave batteries unattended while charging. Do not allow small children to charge or handle LiPo batteries.
- DO NOT disassemble, crush, short circuit, or expose the batteries to flame or other source of ignition.
- DO NOT let any exposed battery contacts or wires touch each other. This will cause the battery to short circuit and create the risk of fire.
- DO NOT leave the charger and battery unattended while charging, discharging, or anytime the charger is ON with a battery connected. If there are any signs of a malfunction, unplug the power source and/or stop the charging process immediately.
- ALWAYS unplug the charger from the wall outlet and disconnect the battery when not in use.
- Never charge LiPo battery packs in series or parallel with this charger. Charging packs in series or parallel may result in improper charger cell recognition and an improper charging rate that may lead to overcharging, cell imbalance, cell damage and fire.
- If a battery gets hot to the touch during the charging process (temperature greater than 110°F / 43°C), immediately disconnect the battery from the charger and discontinue charging.
- DO NOT store or charge LiPo batteries with or around other batteries or battery packs of any type, including other LiPos.
- Store and transport your LiPo batteries in a cool dry place. DO NOT store in direct sunlight. DO NOT allow the storage temperature to exceed 140°F or 60°C or the cells may be damaged and risk of fire created. ALWAYS store battery packs safely out of the reach of children and pets.
- Keep a Class D fire extinguisher nearby in case of fire.
- DO NOT disassemble LiPo batteries or cells. DO NOT disassemble the charger.
- DO NOT attempt to build your own LiPo battery pack from loose cells.
- REMOVE the battery from your model or device before charging.
- DO NOT expose the charger to water or moisture.



## PREPARING FOR FLIGHT

### 1. Charge the battery pack

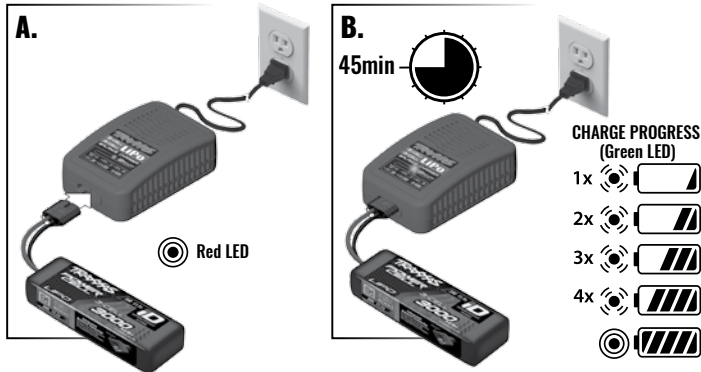

**WARNING!** It is critical to follow all instructions for safe and proper use, charging, and storage of LiPo batteries (see page 5).

### 2. Install batteries in the transmitter



### 3. Turn on the transmitter

The transmitter will emit a rising musical tone. Always turn the transmitter on first, before connecting the helicopter battery.

Green LED on LCD screen flashing "00"

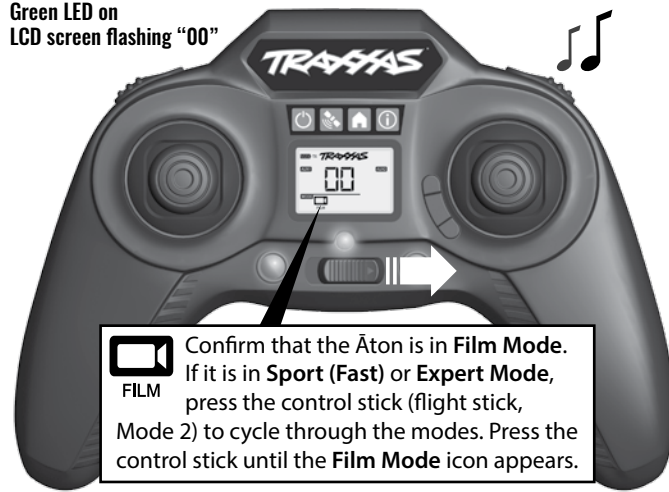

 Confirm that the Aton is in **Film Mode**. If it is in **Sport (Fast)** or **Expert Mode**, press the control stick (flight stick, Mode 2) to cycle through the modes. Press the control stick until the **Film Mode** icon appears.

### 4. Turn on the helicopter

Open the battery compartment (A). Install the fully charged battery with the wires facing the rear of the model. Connect the battery. The helicopter will emit a musical tone and the rear-facing *Power* and *Info* Status LEDs on the helicopter will glow solid. The *GPS* Status LED will blink slowly (B).

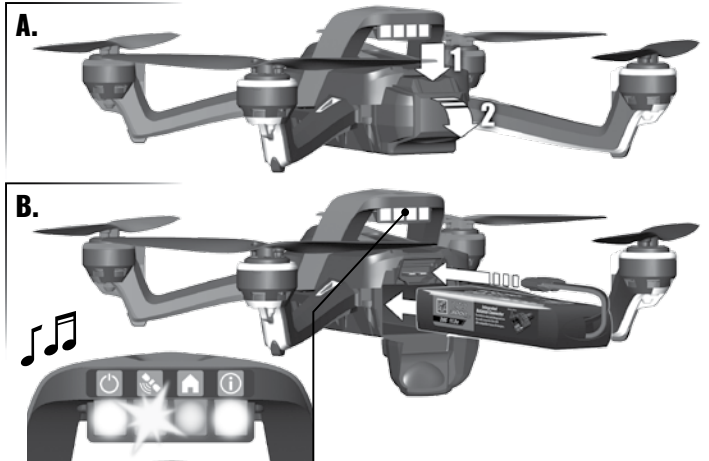

### 5. Locating GPS Satellites

Aton is intended for outdoor flight. Select a flying location with a clear, unobstructed view of the sky. Place the helicopter on a level surface with the Status Bar facing you (nose out).

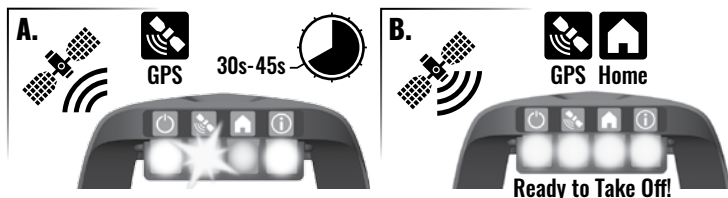

The helicopter will sound a descending tone indicating that the flight system is ready. The *GPS* Status LED on the Status Bar will continue to blink slowly while the helicopter is searching for GPS satellites (A). Once the GPS position is established (usually about a minute), it will also glow solid.

The *Home* Status LED on the Status Bar will then glow solid indicating that the current position of the helicopter has been set as the Return to Home location (B). **When all four LEDs on the Status Bar are solid green, you are ready to take off!**

**Note:** If a GPS signal can not be found, move the helicopter to a different location. We recommend that you do not fly the model without GPS or a Return to Home location (see "Flying without GPS" on page 9). These features are critical to help prevent loss of your helicopter.

### 6. Arm your helicopter for flight

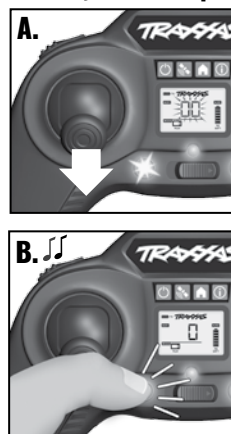

Move the throttle stick to the full down position. The helicopter will not arm unless the throttle stick is in the down position (A). Press and release the *Arm/Disarm* button on the transmitter to arm your model for take off (B). The transmitter will emit a tone and the *Arm/Disarm* button will glow solid green. The helicopter will emit a long tone and all four rotors will spin at idle speed (C). The helicopter is armed and ready for take off.

**Note:** While idling, the helicopter will automatically disarm when the throttle stick is left in the full down position (zero on the LCD screen) for 2 seconds in **Film Mode** or 15 seconds in **Sport Mode**, one or more of the rotors are obstructed, or the helicopter detects an impact.



## AUTO TAKE-OFF

*(Film Mode only)* With the helicopter armed and idling, gently raise the throttle stick to the center position (the LCD screen will read 50%). The transmitter will emit a descending tone until you reach the center position. The center position activates **Auto Take-Off**. The helicopter will automatically take off and maintain hover at 8-10 feet (2-3 meters).



## CONTROLLING ĀTON (FILM MODE)

Your helicopter is set by default to **Film Mode**. Film Mode is the easiest to fly and will allow you to quickly become familiar with the controls.



- **Fly Higher:** Raise the throttle stick past the center position and the helicopter will gain altitude. The transmitter will beep a high tone alerting you that it is climbing. The farther up you move the stick, the faster it will climb. When the desired altitude is reached, move the stick back to the center position (no sound) and the model will maintain altitude.



- **Fly Lower:** Lower the throttle stick past the center position and the helicopter will lose altitude. The transmitter will beep a low tone alerting you that it is descending. The farther down you move the stick, the faster it will descend. When the desired altitude is reached, move the stick back to the center position (no sound) and the model will maintain altitude.



- **Rotating (Yaw):** Move the throttle stick left or right to rotate the model around its center axis. This has no effect on the altitude.



- **Maneuvering:** Move the control stick in the direction you want the model to travel. The farther you move the stick, the faster it will travel. Note that if the helicopter has been rotated so that the front is facing you (nose in), then the controls will seem reversed.

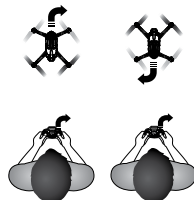

## LANDING

When you are finished flying, either press the Return to Home button to automatically land the helicopter (see *Return to Home below*) or manually land the helicopter in a safe location by gently lowering the throttle stick to the full down position. Once you have safely landed, press and hold the fast blinking green *Arm/Disarm* button on the transmitter for 2 seconds to disarm your model. The helicopter will not disarm unless the throttle stick is in the down position.

## RETURN TO HOME

When all four status LEDs are glowing solid, you can automatically return to your original take-off location at any time during flight by pressing the *Return to Home* button on the transmitter (A).

The *Home* status LED on the Status Bar and the *Home* button on the transmitter will blink slowly (B). The helicopter will position itself with the Status Bar facing the Return to Home location (nose out); then, it will rapidly move in a straight flight path back to the home location, descend, land, and disarm. The transmitter will emit a low-high-mid tone indicating that the model is returning to home. If the helicopter was flying at an altitude below 45 feet (14 meters), it will ascend to this altitude; if it was flying at an altitude above 45 feet (14 meters), it will maintain its current altitude while returning. **Note:** While the helicopter is descending, the control stick can be used to land the Āton in a different location other than the set home position.

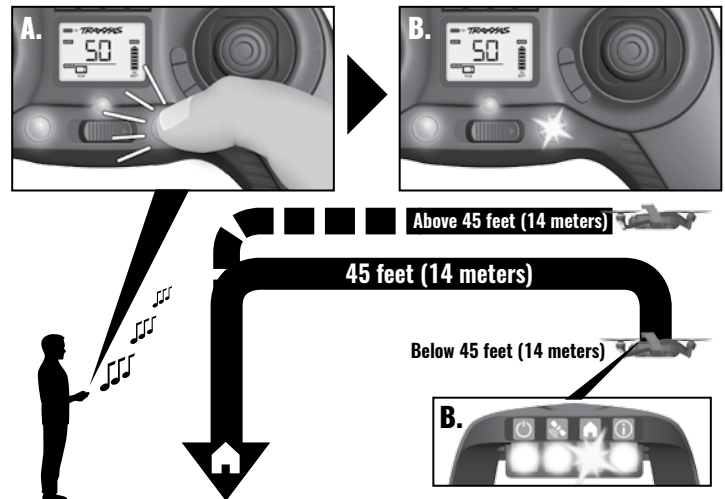

**Note:** The pilot may at any time cancel Return to Home by pressing the *Air Brakes* button. If you press and hold the *Air Brakes* button, the Āton will stop and hover in place. When you release the *Air Brakes* button, the Āton will be operating in **Film Mode**. Depending on where the throttle stick is located, Āton may be moving up or down. If necessary, adjust the throttle stick to move up, move down, or hover. Use this feature to navigate around an obstacle in the Return to Home path of the model. Press the *Return to Home* button on the transmitter to reactivate.

## Resetting Home Location

When you land and disarm the helicopter away from the original home location, the *Home* Status LED and the *Return to Home* button on your transmitter will both blink fast (A).

You can set the new position as the Return to Home landing location by pressing the blinking *Return to Home* button on the transmitter (B).

**Note:** If you do not wish to reset your home landing location, arm the helicopter and continue flying. Āton will retain the original home location.

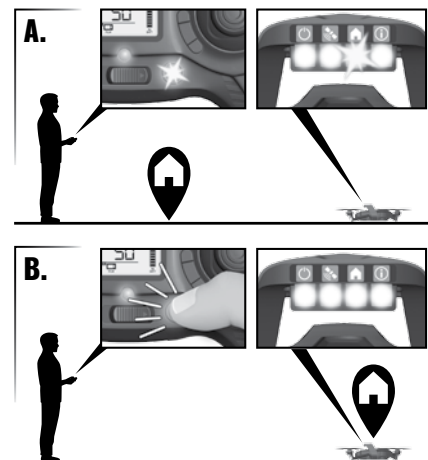



### Return to Home - Out of Radio Control Range Failsafe

The transmitter and helicopter are equipped with an automatic fail-safe system. In the event of signal loss or interference, the transmitter will automatically switch to **Film Mode** and the transmitter will emit the Return to Home sound (low-high-mid tone followed by a beep). The helicopter will automatically return to the home location, land, and disarm (with a set home location) or immediately land and disarm (without a set home location; see "Flying without GPS" on page 9). Determine the reason for signal loss and resolve the problem before operating the helicopter again.

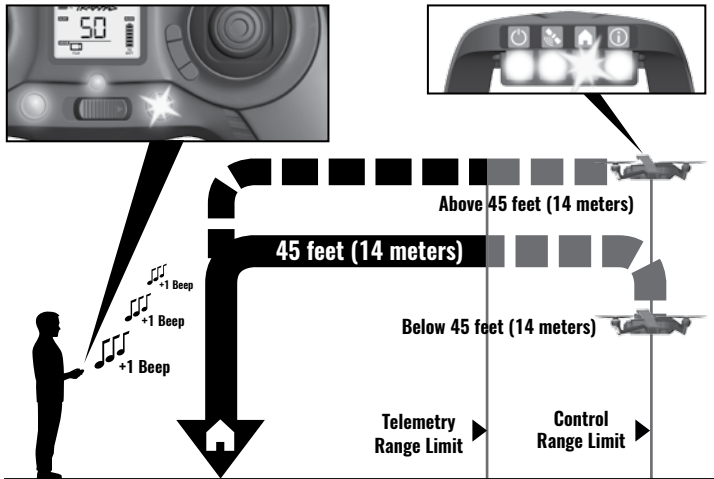

**Note:** If a control signal is reestablished between the transmitter and receiver along the return to home flight path, you may cancel Return to Home by pressing the Air Brakes button (see "Air Brakes" on page 11). Release the button to regain complete control of the model in **Film Mode**.

### Return to Home - Geofence Breach

Åton comes configured with a GPS-controlled boundary (geofence) with a radius of approximately 500 feet (150 meters). When Åton flies beyond this boundary, it will automatically return to home. The transmitter will emit the Return to Home sound followed by 2 beeps, indicating a geofence breach. Once inside the geofence, you may press the Air Brakes button to cancel return to home and continue flying in **Film Mode**. The geofence boundary does not represent the control range of the radio system. You may use the Traxxas Flight Link application to modify the distance of or remove the geofence boundary. Removing the geofence boundary can create situations where the Åton at far distances may perform autonomous behavior (such as Return to Home) and won't be able to communicate to the operator what it is doing until it is back within telemetry range. The geofence boundary keeps Åton approximately within telemetry range for two-way communication between Åton and the operator.

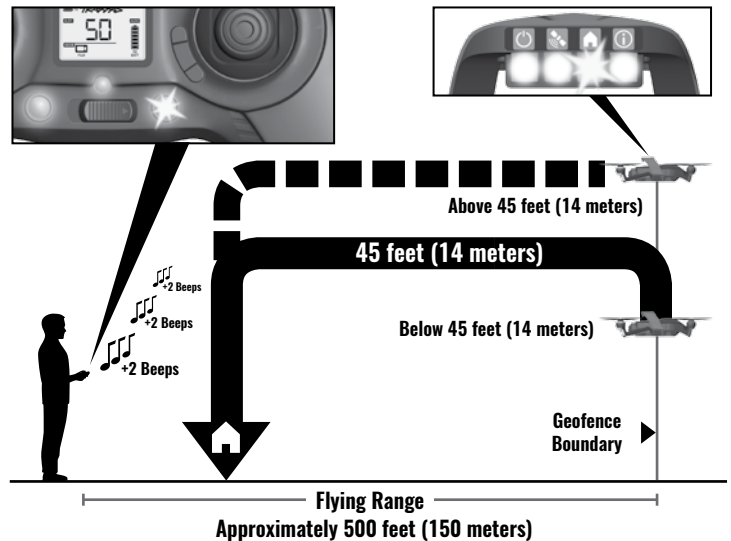

### Return to Home - Low Voltage Failsafe (Telemetry)

Within a range of about 500 feet (150 meters), the helicopter has 2-way communication with the transmitter and will alert you when the battery level is low. When the battery is nearly discharged (approximately 30 seconds before entering low voltage emergency reserve mode), the transmitter will emit a tone every 5 seconds. Immediately fly the helicopter to a safe location and land it. In the last 5 seconds, the tone will be continuous. After that, the transmitter will emit the Return to Home sound (low-high-mid tone followed by 3 beeps) and the helicopter will automatically return to the home location, land, and disarm. If necessary, use the Air Brakes button to cancel Return to Home to steer around unexpected obstacles in the return to home path. Once clear, press the Return to Home button again to continue, or maneuver and land the Åton on your own as quickly and safely as possible. **WARNING: DO NOT** always rely on the emergency reserve return to home function to land. Conditions such as distance, wind, and temperature can affect the battery's end of charge reserve, resulting in a shutdown in flight. **DO NOT** ignore the first battery low voltage warning, but safely return and land as soon as possible. To prevent permanent damage to your battery pack, **ALWAYS** disconnect the battery whenever the helicopter is not in use. Please note that if you have disabled or increased the radius of the default geofence, this will affect your ability to receive battery alerts. Refer to the section "Flying without the Geofence Protection" on page 9 for more information.

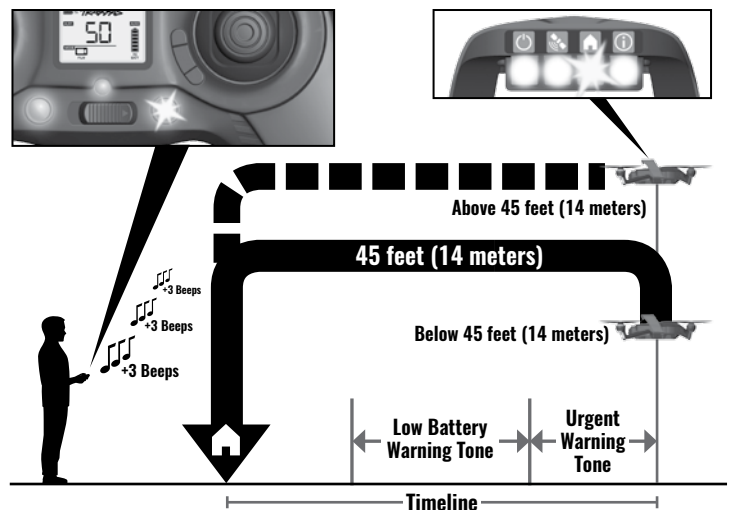

## Return to Home is Your Extra Security

Āton's sophisticated Return to Home functions are there to help whenever you need it. If you ever encounter a difficult or uncomfortable situation, such as losing directional orientation, loss of visual contact, high winds, flying too high and so on, simply press the *Return to Home* button. Let Āton bring itself back to you quickly and safely. Āton's Return to Home function can be especially helpful if you are learning how to fly for fun in **Sport** or **Expert Modes**.

## Flying without GPS (without a Return to Home Location)

**WARNING:** The Āton has tremendous power and capability; it can very easily get out of your line of sight. Flying the helicopter without a satellite GPS signal and a set Return to Home location has the risk of losing your helicopter. We do not recommend flying Āton without GPS fully enabled and functioning. If the helicopter encounters an emergency situation during flight without GPS, such as loss of the radio control signal or critically low battery, Āton will attempt to safely land and disarm. This can result in loss of the Āton if it is, for example, over water or some other area where it can't be retrieved. To help prevent problems, always fly with GPS enabled and avoid flying over areas where an unexpected emergency landing could endanger the Āton or nearby people and property.

If for some reason you decide it is necessary to operate Āton without GPS, you can override the satellite search function by pressing and holding the *Arm/Disarm* button on the transmitter for 2 seconds. This will arm the helicopter for flight, but the Return to Home function will be deactivated (the *GPS Status LED* on the Status Bar will continue to blink green slowly during flight).

When you are finished flying, land the helicopter in a safe location. Move the throttle stick to the full down position. Press and hold the fast blinking green *Arm/Disarm* button on the transmitter for 2 seconds to disarm your model. The helicopter will not disarm unless the throttle stick is in the full down position.

**Note:** If a satellite GPS signal is found during flight, the *GPS Status LED* on the Status Bar will glow solid green indicating that the Return to Home function is now active. This location will be set as the Return to Home location. To choose a different location, land the helicopter, disarm it, and then follow the instructions in the "Resetting Home Location" section on page 7.

## Flying without the Geofence Protection

The Āton is programmed with default geofence protection that keeps Āton within the range of the telemetry communication. The geofence radius is set to about 500 feet (150 meters) and can be adjusted or removed using the Traxxas Flight Link App. If you remove the geofence, you can encounter situations where the Āton is flying autonomously (such as Return to Home) without providing information to the pilot about its actions until it flies within telemetry range. Once in range, the transmitter will provide alerts to the pilot. For example, if the Āton's battery reaches the end of its charge while the Āton is flying beyond telemetry range, the pilot will not receive the progression of prompts from the transmitter to return and land. When the battery reaches its critical threshold, Āton will return to home automatically without alerting the pilot until Āton is inside telemetry range with the Return to Home sound followed by three beeps. When you observe the Āton flying autonomously and returning to home, do not cancel return to home until you receive an alert that informs you of the reason it is returning to home. If the reason is a low battery, then allow Āton to return and land on its own. We recommend that pilots do not disable or extend the geofence range unless they are fully familiar and confident in how the Āton responds to different circumstances.

**i** If one or more of the rotor blades are obstructed, the helicopter will disarm itself. Move the helicopter to a clear area, remove the obstruction, arm the helicopter again, and continue flying. If the helicopter will not fly correctly, unplug the battery and inspect the helicopter for damage.

## "FIND ME" BEEPER

If the helicopter lands and disarms out of your line of sight, it is equipped with a beeper to help determine its location. To activate the beeper, move the throttle stick on the transmitter to the full down position (the beeper will not activate unless the throttle stick is in the down position); then, move the flight stick right and back.

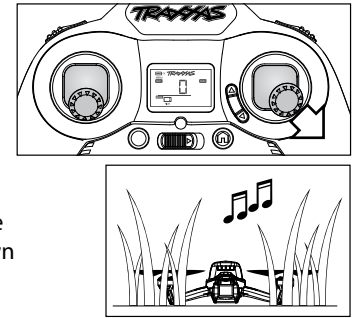

## HELPFUL FLYING TIPS

**Controls are reversed as the model flies toward you.**

- When your model is flying away from you, the helicopter reacts to direction changes just as you command. If you command the model to move right, it will move to your right as you commanded.
- When the helicopter is coming toward you and you command the model to move right, the model will move to your left. Always remember that the model flies forward, reverse, right, and left relative to the position of itself, not relative to your position.
- Until you become used to reversing your control inputs as the model changes direction, allow yourself extra flying room to accommodate pilot error.
- To help with directional control, it may help to imagine yourself sitting in the cockpit of the helicopter.
- The model will react quickly to your commands. At first, move the controls SLOWLY and make small, gentle control movements to avoid loss of control. If you ever feel you don't have complete control of the helicopter, maintain altitude with the throttle stick and release the opposite stick to return to level flight (**Film** and **Fast Mode**).
- Fly the Āton with the Status Bar facing you (nose out) until you become familiar with the flight controls and different behaviors of the helicopter.
- Fly at least 8-10 feet (2-3 meters) above the ground to avoid ground turbulence for a more stable and controllable flight.

**i** **Be prepared for altitude changes as you fly.** Forward/reverse and left/right movements may increase or reduce lift, causing the helicopter to gain or lose altitude. Be prepared to react to altitude changes by adjusting the throttle as you fly the model.



## CAPTURING VIDEO

### Film Mode

The transmitter will always power up in **Film Mode**. Film Mode is the easiest to fly (see "Controlling Aton" on page 7 for flight control instructions).

Install the included landing gear and fixed camera mount to the Aton; then, use your GoPro® or other action camera and accessories (not included)\* to capture aerial video.

**IMPORTANT:** Consult local laws and ordinances before installing and operating any type of photograph-capable or video recording device on this model.

**WARNING:** To prevent radio interference and loss of control, always disable Wi-Fi on your GoPro® or other action camera (if so equipped) BEFORE flying the Aton.

**WARNING:** Some GoPro® cameras, specifically the Hero 3 and Hero 4 series with LCD screen, are known to produce radio frequency emissions that could interfere with Aton's ability to acquire GPS satellite communications. The Aton is equipped with shielding to help protect it from these radio frequency emissions. Use caution with these cameras and test in a safe area to be sure Aton is acquiring GPS satellites and setting a Return to Home location when these cameras are attached, powered on, and recording video. DO NOT operate Aton with these cameras if you are not connected to GPS (four green LEDs on the Status Bar).

### 1. LANDING GEAR INSTALLATION

Use the included 2.6x8mm screws to mount the front and rear landing gear to the helicopter.

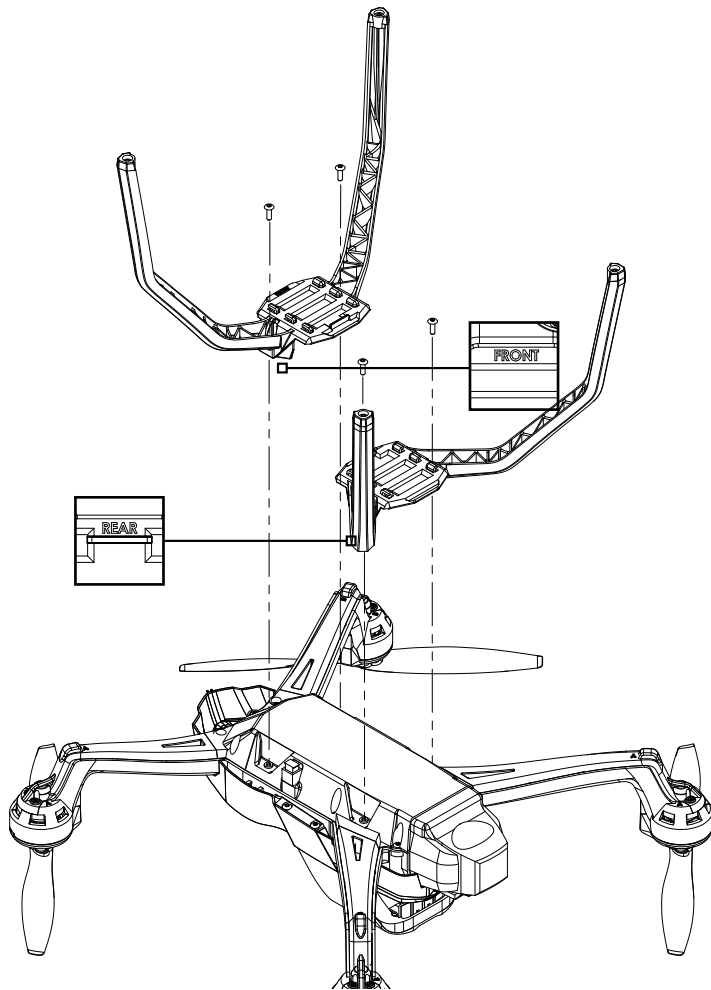

### 2. CAMERA BRACKET INSTALLATION

Attach the fixed camera mount to the front landing gear by aligning the tabs. Slide the mount toward the rear of the helicopter until the tabs snap into place.

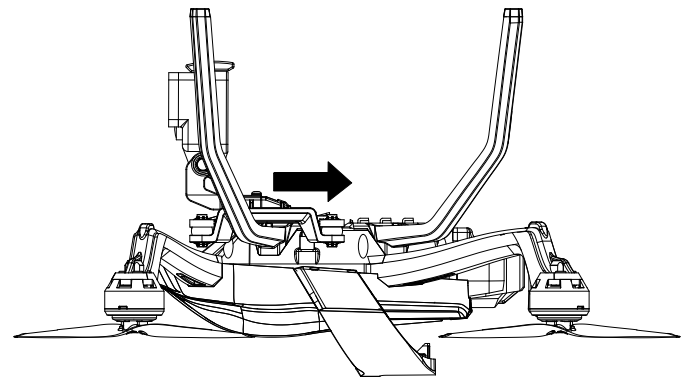
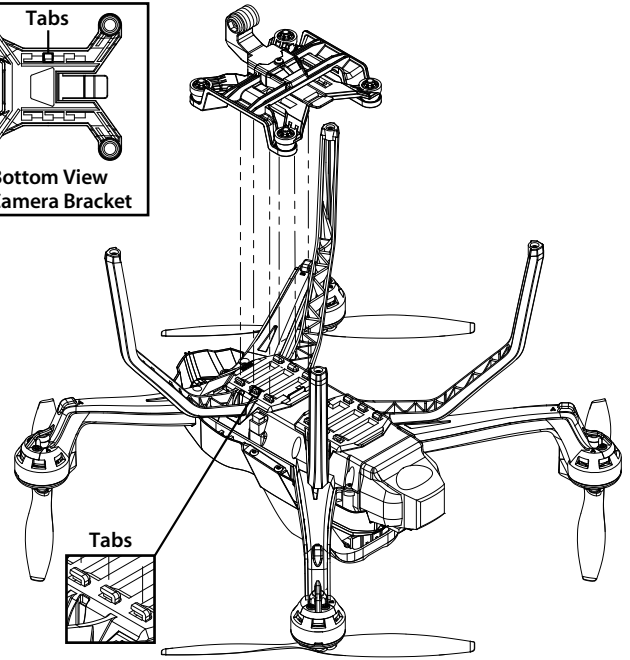
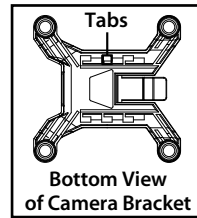

### FINAL ASSEMBLY

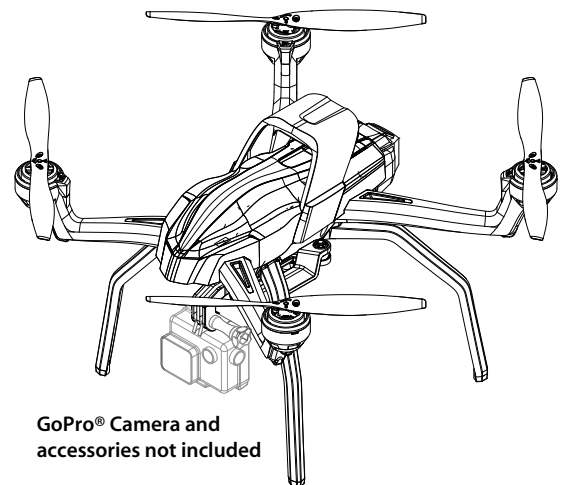

GoPro® Camera and accessories not included

**Note:** The following instructions are for Mode 2 transmitters (throttle stick on the left, flight control stick on the right).

## Sport Mode

For those that want to go beyond simply directing Āton in the sky and explore what it's like to actually take more control and fly, Āton is equipped with **Sport Mode**.

Sport (Fast) Mode uses the full capability of the 6-axis flight control system (auto leveling) for high-speed sport flying. Altitude hold is disabled and both altitude and throttle are controlled by the throttle stick (left stick, Mode 2). Sport Mode also enables trick functions.

To enter Sport Mode, the Āton should be powered on and disarmed. Press to click the flight control stick (right stick) once to toggle the Āton into Sport Mode. The transmitter will beep 2 times, the green LED will begin flashing, and the LCD will display FAST.

### Performing tricks

In Sport (Fast) Mode, Āton can perform automated expert flips and rolls when you press the AUX1 button, and then enter a quick stick command in the chosen direction. **Do not attempt these flight tricks until you are able to fly confidently in Sport Mode.** Choose an area that will provide a soft landing and maintain enough altitude to allow room to recover control as you practice flipping the model. The number of flips and rolls performed can be set using the Traxxas Flight Link App (see page 14 for more information).

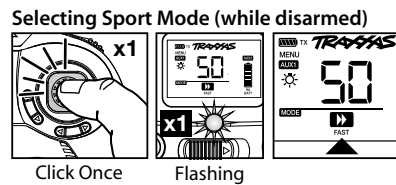

There are also menu functions in the transmitter that allow you to customize the settings. Refer to the instructions online for using the transmitter menu.

**Note:** Always remove camera frame and landing gear BEFORE attempting flight tricks.

## AIR BRAKES

If you lose control of Āton at any point, press and hold the *Air Brakes* button and Āton will come to a stop and hover in place. When you are ready, release the *Air Brakes* button and continue flying in the currently selected mode (Film, Sport, or Expert).

## RETURN TO HOME

The *Return to Home* button may be pressed at anytime to stabilize Āton and return it to you. You may cancel return to home by pressing and releasing the *Air Brakes* button. Āton will then be flying in **Film Mode** under your control.

## ADVANCED: CHANGING MODES DURING FLIGHT

Advanced pilots may find it helpful to be able to change modes during flight. For example, if you are flying in **Sport Mode**, use Return to Home, and then cancel return to home. Āton will then be flying in **Film Mode**. You can switch back to **Sport Mode** and continue flying by pressing and holding the *Air Brakes* button, and then pressing (clicking) the flight control stick to toggle through the modes...one click for **Sport Mode**, 2 clicks for **Expert Mode**. Release the *Air Brakes* button to continue flying in the selected mode.

### Front and Back Flips

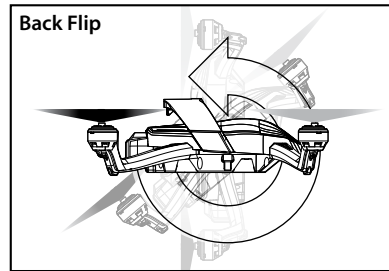
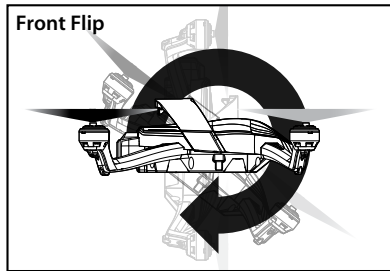
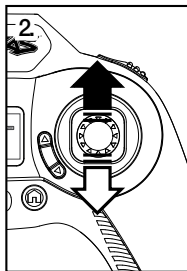
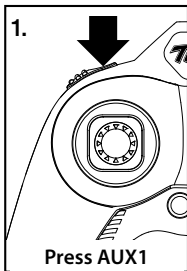

### Diagonal Front and Back Flips

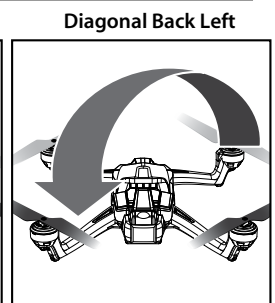
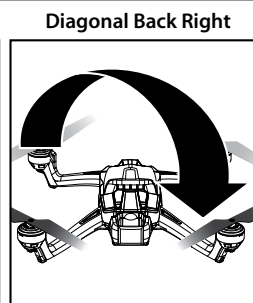
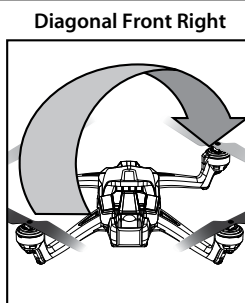
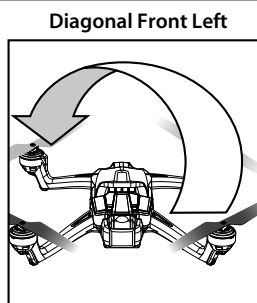
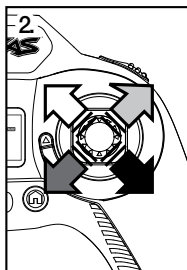
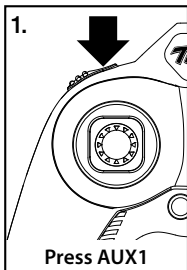

### Side Flips

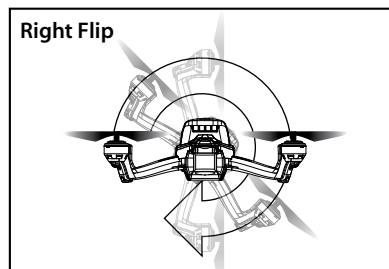
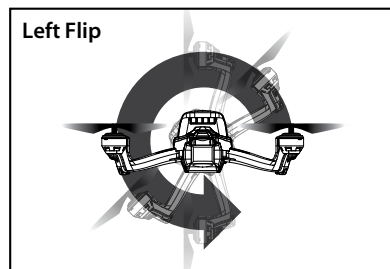
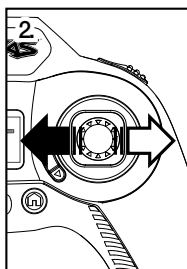
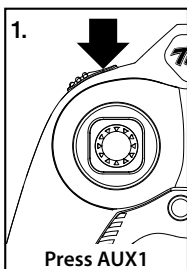

## Expert Mode

In **Expert Mode**, the 6-axis flight control system (auto leveling) is disabled, allowing the pilot to have full control over all aspects of flight. Expert Mode is truly for experts. If you find yourself flying **Āton** out of control, press and hold the *Air Brakes* button or press the *Return to Home* button. When flying in Expert Mode, move the flight stick toward the highest side of the helicopter (left or right) to level it. Choose a location that allows you to fly over grass or another soft surface.

From Film Mode with the helicopter landed and disarmed, click the flight stick twice to activate Expert Mode. The transmitter will beep 3 times, the green LED will begin double flashing, and the LCD will display EXPERT.

**WARNING: This mode is intended for expert level pilots only! For more information on how to perform expert tricks and flips and learn how to access the menu and advanced controls, visit [Traxxas.com](http://Traxxas.com) for additional details and instructions.**

## CARING FOR YOUR HELICOPTER

- After each flight and immediately after any crash, inspect your model for worn or damaged parts. If required, parts are available from your local Traxxas hobby dealer or at [Traxxas.com](http://Traxxas.com). For a complete parts list and exploded view of your model, refer to the Service and Support Guide in this manual.
- When not in use, store your model in its original packaging with the batteries removed from the transmitter and helicopter.
- If you do not plan to fly your model for a week or more, store the battery approximately 50% charged to maintain battery performance and life. To achieve a 50% charge, fly the model until the battery requires recharging. Charge the battery for half the time typically required to fully charge the battery or fly the model until a 50% charge remains.

**WARNING!** Do not store or attempt to charge a swollen or damaged battery! See "Safety Precautions" on page 5 for more information on LiPo batteries.

## ROTOR BLADE INSTALLATION

The **Āton's** rotor blades are not identical. Each blade is labeled with an A or B. When installing replacement rotor blades, be certain to install the rotor blades with the corresponding A or B for each of the legs (A or B labels for the legs are molded on the LED lens). The helicopter will not fly if the rotor blades are not installed in the proper locations.

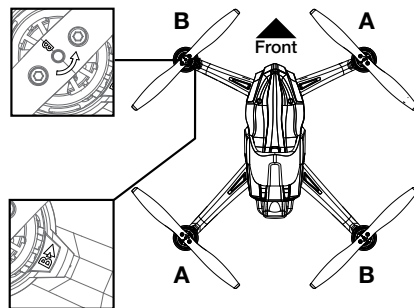

### Selecting Expert Mode (while disarmed)

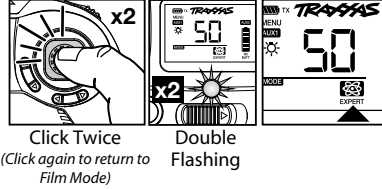

## LED STATUS BAR

The LED Status Bar on the model is your flight information center. The chart below defines common Status Bar messages.

	Power	GPS	Home	Info
<b>On</b> (Working / Available)	Linked to transmitter	GPS signal acquired	Home location set	All systems normal, Ready to Fly
<b>Off</b> (Not Available)	Battery disconnected	–	Return to Home not available	Battery disconnected
<b>Slow Flashing</b> (Active)	Looking for transmitter signal	Searching for satellites	Return to Home active	Low battery
<b>Fast Flashing</b> (User Action Needed)	Transmitter signal lost	–	Helicopter has landed away from the set home location	–

## TRANSMITTER CODES

- Home Button Fast Flashing:** Helicopter has landed away from set home location
- Home Button Slow Flashing:** Helicopter returning to home landing location
- Arm/Disarm Button Flashing:** Helicopter is disarmed
- Power Indicator Flashing:** Low batteries in transmitter; land immediately

## RETURN TO HOME REFERENCE GUIDE

Tone/Beep Pattern	Name	Description
Low-mid-high tone	Return to Home	Return to Home button pressed
Low-mid-high tone + 1 beep	Out of Radio Control Range	Radio signal loss or interference
Low-mid-high tone + 2 beeps	Geofence Breach	Āton has flown beyond GPS-controlled boundary (geofence)
Low-mid-high tone + 3 beeps	Low-Voltage Failsafe	Transmitter or helicopter battery is nearly discharged.

## TROUBLESHOOTING GUIDE

- **The helicopter can't find a satellite GPS signal.**
  1. Certain surfaces can cause signal interference between the helicopter and GPS satellites. Move the helicopter to different launch locations and away from buildings, parked cars, and other obstructions until a signal can be established. **We don't recommend flying without a GPS signal.**
- **The transmitter and the helicopter are on, but the helicopter won't fly.**
  1. The model is not armed or has timed-out. See step 6 of the "Flying Your Model" section to arm your helicopter.
- **The helicopter does not perform a trick when the AUX1 button is pressed and then a stick command is given.**
  1. The transmitter is not in Fast Mode. See the "Flight Modes" section.
- **The helicopter landed by itself, and now the throttle will not respond.**
  1. The helicopter battery needs to be recharged (low voltage).
- **The LED is blinking on the transmitter, and the transmitter will not control the model.**
  1. **The transmitter is in binding mode.** Confirm that the helicopter is powered on and the transmitter is in binding mode (blinking LED, LCD displays rotating segments). Move the transmitter to within one foot of the helicopter. The transmitter and helicopter should bind (indicated by a tone from the transmitter, solid green LED on the transmitter, solid green *Power* and *Info* Status LED on the helicopter, and the Disarmed Flight Screen on the transmitter LCD).
  2. **There was a problem with the binding process.** Power down the transmitter and the helicopter, and then power them on again (transmitter first, then helicopter). The transmitter and helicopter should bind (indicated by a tone from the transmitter, solid green LED on the transmitter, solid green *Power* and *Info* Status LEDs on the helicopter, and the Disarmed Flight Screen on the transmitter LCD).
  3. **The model is not armed or has timed-out.** To arm your helicopter, see step 6 of the "Preparing for Flight" section on page 6.
- **The transmitter settings have been adjusted incorrectly for optimal flight.**
  1. Return the transmitter to the default settings.
    - A. Ensure the transmitter is off.
    - B. Press and hold the AUX2 button and the Menu Down button.
    - C. While holding both buttons, turn the transmitter on.
    - D. Continue holding both buttons for 3 seconds until the transmitter beeps. Release both buttons.
    - E. The transmitter is reset and is in bind mode (blinking LED, LCD displays rotating segments).
    - F. Confirm that the helicopter is powered on and is in binding mode (*Info* Status LED blinking fast green).
    - G. Move the transmitter to within one foot of the helicopter. The transmitter and helicopter should bind (indicated by a tone from the transmitter, solid green LED on the transmitter, solid green *Power* and *Info* Status LEDs on the helicopter, and the Disarmed Flight Screen on the transmitter LCD).
- **The helicopter battery is fully charged and the rotor blades are spinning, but the helicopter will not lift off.**
  1. The rotor blades have been installed incorrectly. See "Rotor Blade Installation."
- **The helicopter does not fly as expected or the helicopter performs erratically in Film Mode.**
  1. The helicopter has lost the GPS signal. Fly the helicopter to a suitable flying area with a clear view of the sky to reestablish the GPS signal.
- **The helicopter does not fly as expected or the helicopter performs erratically in Fast or Expert Mode.**
  1. **The accelerometer or flight compass needs to be reset.** Go to Traxxas.com for additional information and instructions or call the Traxxas Technical Support Line toll-free at: 1-888-TRAXXAS (1-888-872-9927).

## ADVANCED TUNING GUIDE

Programming your helicopter with your Apple iPhone, iPad, iPod Touch, or Android device

The Aton is equipped with Bluetooth®. This transforms your Apple® iPhone®, iPad®, iPod touch®, or Android™ device into a powerful tool that equips the Aton with an intuitive, high-definition, full-color graphical user interface.

### Traxxas Flight Link™ App

The powerful Traxxas Flight Link App (available in the Apple App Store™ or on Google Play™) makes it easy to learn, understand, and access powerful tuning and adjustment options. Use the app to verify flight status and GPS connection or confirm transmitter and receiver radio signal. Adjust flight controls and settings by simply touching and dragging the sliders on the screen.



- Check helicopter flight status
- Adjust Film Mode speeds
- Navigate the transmitter Menu Tree
- Program the AUX1 button functions
- Modify geofence boundaries
- Adjust helicopter LED light settings
- Select and save user profiles
- Upgrade the helicopter firmware



The Traxxas Flight Link app contains step-by-step instructions for pairing the app with your Aton via Bluetooth®.

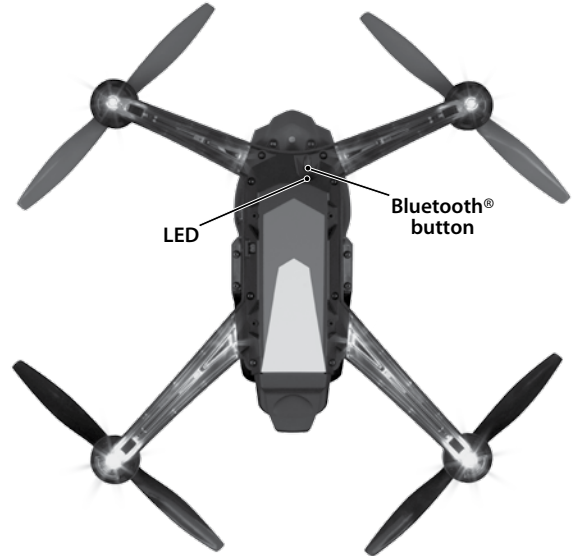

If you do not have a smart phone or similar device, the transmitter contains a menu that allows you to adjust flight settings and customize buttons. Visit [Traxxas.com](http://Traxxas.com) for a guide to using the built-in transmitter menu functions.

### Updating Firmware:

Your Aton has the ability to receive firmware updates that can add new features and capabilities. Firmware updates are performed via a microSD card (not included) that installs on the main board. The microSD card slot can be accessed by removing the front canopy (two screws). Visit [Traxxas.com](http://Traxxas.com) for the latest firmware updates and instructions for how to install them on your model.

### Ground Control Station:

Aton's autonomous flight control is open source and it is compatible with ground control station applications, such as Mission Planner, available at [www.dronecode.org](http://www.dronecode.org). With Mission Planner you can review flight logs, overlay your path onto maps, and see your altitude.\*

\*Viewing flight logs requires a desktop PC and installation of a micro SD card (not included).

© 2015 Google – Map data © TeleAtlas, imagery © 2015 TerraMetrics

**Aton software contains open source components. Please visit [Traxxas.com/](http://Traxxas.com/) open-source for license information.**

Compatible with:	iPhone 4S
iPod touch (5th generation and later)	iPhone 5
iPad (3rd generation and later)	iPhone 5C
iPad mini	iPhone 5S
Android 4.4 (and later)	iPhone 6
	iPhone 6 Plus

Apple, the Apple logo, iPhone, iPad, and iPod touch are trademarks of Apple Inc., registered in the U.S. and other countries. App Store is a service mark of Apple Inc. Android and Google Play are trademarks of Google Inc.





## TRAXXAS SERVICE AND SUPPORT

Phone: 1-888-TRAXXAS (1-888-872-9927) (US residents only) \*  
1-972-549-3000 \*

Online: [Traxxas.com/support](http://Traxxas.com/support)

E-mail: [support@Traxxas.com](mailto:support@Traxxas.com)

\*Monday through Friday from 8:30am to 9:00pm central time.

### Warranty Coverage

Your new helicopter is considered to be a hobby-class model. We have made every effort in component design, material selection, and assembly to make our products as durable as possible. Because our products are not considered to be "toys," no warranties are expressed or implied that cover damage caused by normal use or wear, or cover or imply how long any part will last before requiring replacement due to wear. Parts will wear from use and occasionally require replacement. The helicopter and its components are only covered against manufacturer's defects in materials, workmanship, or assembly when new (before being used).

If any component is found to be defective, incorrectly made, or incorrectly assembled within the warranty coverage time period (where applicable), it will be repaired or replaced at the sole discretion of Traxxas. This will be done within a reasonable time period and free of charge. If you believe a defect in materials, workmanship, or assembly was not apparent when the product was new and only became evident after the product was used, then please contact Traxxas Technical Support. We stand behind our products and reputation and pledge to do our best to make sure you are satisfied with your Traxxas product.

### Electronic Components

Traxxas electronic components are warranted to be free from defects in materials and workmanship for a period of thirty (30) days from the date of purchase. Electronic components consist of the radio system (transmitter, receiver, servos, switches, chargers, adapters, and receiver battery holders) and any other Traxxas electronic component. See the additional limitations that apply.

### Limitations

Any and all warranty coverage does not cover replacement of parts and components damaged by abuse, neglect, improper or unreasonable use, crash damage, water or excessive moisture, chemical damage, improper or infrequent maintenance, accident, unauthorized alteration or modification, or items that are considered consumable. Traxxas will not pay for the cost of shipping or transportation of a defective component to us. This warranty is limited to the charger only and does not cover batteries, vehicles, and other accessories used in conjunction with the charger.

### Your Hobby Dealer's Role

All warranty claims are handled directly by Traxxas. Your dealer can assist you in contacting Traxxas and determining which components might be defective, but he is under no obligation to provide free replacement parts or service. Traxxas does not authorize dealers to make over-the-counter exchanges or refunds for Traxxas products that have been used. Traxxas will make the sole and final determination if a product or component can be covered under warranty.

### Limitations of Liability

Traxxas makes no other warranties expressed or implied, including the implied warranties of MERCHANTABILITY or FITNESS FOR A PARTICULAR PURPOSE. Traxxas shall not be liable for any special, indirect, incidental, or consequential damages arising out of the assembly, installation, or use of their products or any accessory or chemical required to use their products. By the act of operating/using the product, the user accepts all resulting liability. In no case shall Traxxas' liability exceed the actual purchase price paid for the product. Traxxas reserves the right to modify warranty provisions without notice. All warranty claims will be handled directly by Traxxas. This warranty gives the customer specific legal rights and possibly other rights that vary from state to state. All dollar amounts stated are in United States dollars. The term "lifetime" shall refer to the product's production life at Traxxas. Traxxas is not obligated to provide upgraded products at a reduced rate when a previous product's production cycle has ended.

*Traxxas encourages you to register your model online at [Traxxas.com/register](http://Traxxas.com/register).*

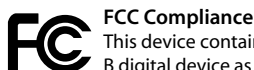

### FCC Compliance

This device contains a module that complies with the limits for a Class B digital device as described in part 15 of the FCC rules. Operation is subject to the following two conditions: (1) This device may not cause harmful interference, and (2) this device must accept any interference received, including interference that may cause undesired operation.

The limits for a Class B digital device are designed to provide reasonable protection against harmful interference in residential settings. This product generates, uses, and can radiate radio frequency energy, and, if not operated in accordance with the instructions, may cause harmful interference to radio communications.

The user is cautioned that changes or modifications not expressly approved by the party responsible for compliance could void the user's authority to operate the equipment.

### Canada, Industry Canada (IC)

This Class B digital apparatus complies with Canadian ICES-003 and RSS-210. This device complies with Industry Canada license exempt RSS standard(s). Operation is subject to the following two conditions: This device may not cause interference, and this device must accept any interference, including interference that may cause undesired operation of the device.

### Radio Frequency (RF) Exposure Information

This equipment complies with radio frequency exposure limits set forth by FCC and Industry Canada for an uncontrolled environment. This equipment should be installed and operated with a minimum distance of 20 centimeters between the radiator and your body or bystanders and must not be co-located or operated in conjunction with any other antenna or transmitter.



### Battery Recycling (for U.S.A.)

The Rechargeable Battery Recycling Corporation (RBRCTM) seal on your model's included battery indicates that Traxxas is voluntarily participating in an industry program to collect and recycle these batteries at the end of their useful lives, when taken out of service within the United States. The RBRCTM program provides a convenient alternative to placing used NiMH batteries into the trash or municipal waste system, which is illegal in some areas. Please call 1-800-8-BATTERY (1-800-8-228-8379) for information on battery recycling in your area. Traxxas' involvement in this program is part of its commitment to protecting the environment and natural resources that we all share. RBRCTM is a trademark of the Rechargeable Battery Recycling Corporation.



### CE Compliance for Users in the European Union

**WEEE Compliance:** Please help the environment by disposing of your product responsibly at the end of its life. The wheeled bin symbol indicates that this product should not be disposed of in your household waste containers. Instead, the product should be disposed of by using a designated collection point for the recycling of waste electrical and electronic equipment. The Waste of Electrical and Electronic Equipment (WEEE) Directive (2002/96/EC) requires that the best available recycling techniques be employed to minimize the impact on the environment.

Recycling electronics helps by keeping harmful chemicals out of the environment, and also saves money by reusing precious metals. Remove any batteries and dispose of them and the product at your local authority's recycling facility. For more information about where you can drop off your waste equipment for recycling, please contact your local city office, your household waste disposal service, or the location where you purchased this product.

### Declaration of Conformity for R&TTE Directive In accordance with IEC 17050-1

This is to certify that the following products conform to the requirements of the R&TTE Directive 99/5/EC and that all essential test suites have been carried out.

**Product: Traxxas Áton (7908) / Áton Plus (7909) Quad Rotor Helicopter)**  
Operating Frequency Range: 2406MHz to 2453MHz

### Standards applied:

EN 300 328 v1.8.1:2012	EN 55014-1:2006+A1:2009+A2:2011
EN 300 440-1 v1.6.1:2010	EN 55014-2:1997+A1:2001+A2:2008
EN 300 440-2 v1.4.1:2010	EN 61000-3-2:2014
EN 301 489-1 v1.9.2:2011	EN 61000-3-3:2013
EN 301 489-3 v1.6.1:2013	EN 60335-1:2012+A11:2014
EN 301 489-17 v2.2.1:2012	EN 60335-2-29:2004+A2:2010
EN 55022:2010/AC:2011	EN 62233:2008
EN 60950-1:2006+A11:2009+A1:2010+A12:2011+A2:2013	

Signed: Date: **December 11, 2015**

Traxxas, 6250 Traxxas Way, McKinney, Texas 75070

THIS MODEL IS NOT INTENDED FOR USE BY CHILDREN UNDER THE AGE OF 14 WITHOUT THE SUPERVISION OF A RESPONSIBLE ADULT.

### WARNING!

POTENTIAL CHOKING HAZARD! KEEP THIS MODEL, ITS TRANSMITTER, AND EXTRA EQUIPMENT OUT OF THE REACH OF CHILDREN UNDER 3 YEARS OF AGE!



**MODEL 7908/7909**

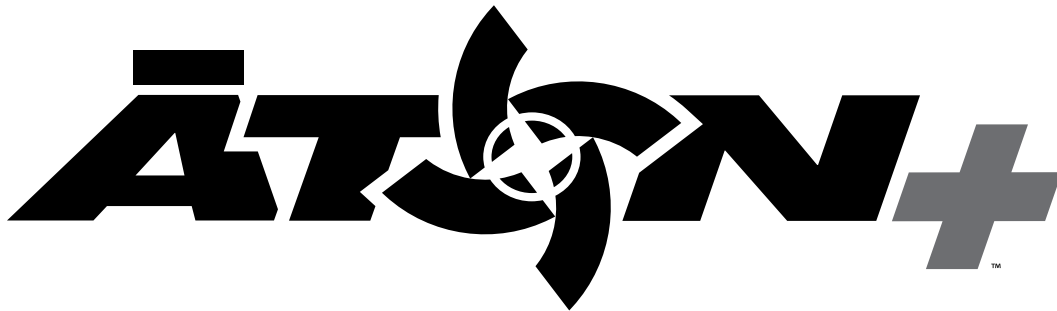

Traxxas, 6250 Traxxas Way, McKinney, Texas 75070 • Phone: 972-549-3000 • 1-888-TRAXXAS (U.S. Only) • Traxxas.com • E-mail: support@Traxxas.com  
©2015 Traxxas. No part of this manual may be reproduced or distributed in print or electronic media without the express written permission of Traxxas. The product may vary from the images contained within. Specifications are subject to change without notice. Aucune partie de ce manuel ne peut être reproduite ou distribuée dans les médias imprimés ou électroniques sans l'autorisation expresse écrite de Traxxas. Le produit peut différer des images qu'il contient. Les spécifications sont sujettes à changement sans préavis. Ninguna parte de este manual puede ser reproducido o distribuido en medios impresos o electrónicos sin autorización expresa por escrito de Traxxas. El producto puede diferir de las imágenes que contiene. Las especificaciones están sujetas a cambios sin previo aviso. Kein Teil dieses Handbuchs darf kopiert oder verbreitet werden in Print-oder elektronischen Medien ist ohne ausdrückliche schriftliche Genehmigung von Traxxas. Die Spezifikationen können ohne Ankündigung geändert werden. Das Produkt kann von den Bildern enthaltenen variieren.