

Futaba

GYA460

6-axis Flight Control

Instruction Manual



S.BUS



Thank you for purchasing the GYA460. Before using your new gyro, please read this manual thoroughly and use the gyro properly and safely. After reading this manual, store it in a safe place.

INTRODUCTION

The GYA460 is a flight attitude controller and stabilizer designed exclusively for model aircraft. In addition to control by 3 axis gyro sensor, flight attitude is controlled by a 3 axis G-sensor. Besides a beginners mode, which assists flight by beginners by automatic horizontal level return control and flight attitude angle control, a gyro-mode and gyro off mode can also be selected.

FEATURES

- Low profile, small size and light weight.
- Easy setup
- S.BUS compatible. Only one connection is necessary between the S.BUS receiver and GYA460.
- Three flight modes can be selected by transmitter switch.
- Sensitivity adjustment can set aileron, elevator, and rudder separately by GYA460 trimmer.
- Parameters can be set by GYA460 SET button and LED.
- Tailless wing compatible.

*Attitude cannot be controlled in the stalled state in which the rudder is ineffective.

*2-Aileron, flaperon, air brake mixing can't be used.

*Always use only genuine Futaba transmitters, receivers, servos and other optional accessories.

SPECIFICATIONS

- Gyro sensor: MEMS vibrating structure gyro
- Operating voltage : DC4.0 ~ 8.4V
- Current drain : 44 mA
- Operating temperature range :
-10° ~ +45°
- Dimensions : 35 × 27 × 12mm
- Weight : 10g

SET CONTENTS

- ① GYA460 × 1
- ② Double Sided Tape × 1
- ③ 3-Signal Cord × 1
- ④ Extension Cord × 2
- ⑤ Mini Screwdriver × 1
- ⑥ Manual × 1
- ⑦ Quick Reference × 1

①

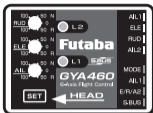

②



③

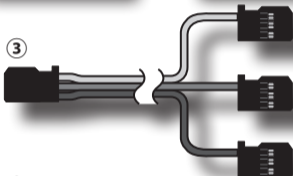

④

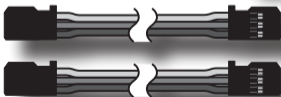

⑤



PRECAUTIONS

WARNING

Failure to follow these safety precautions may result in severe injury to yourself and others.

- ❗ **Check that there is sufficient transmitter battery capacity for flight.**

- Determine the operating time of the receiver, gyro, and servo battery in the adjustment stage and decide the number of flights with a margin to spare.

- ❗ **Always check the direction of operation of the gyro.**

- Attempting to fly with the operating direction reversed is extremely dangerous. Always check your gyro's direction to ensure safe flights.

- ⊘ **Do not strike the gyro with a hard object. Do not drop it onto a concrete surface or other hard floor.**

- The sensor may become damaged during strong impacts.
-

⊘ **Do not use the GYA460 for applications other than RC electric airplanes.**

- This gyro is designed for RC electric airplanes only. Do not use it for other applications.
-

ⓘ **The GYA460 assists flight by beginners. However, this does not mean that RC model aircraft can be flown alone by a completely unexperienced flyer. Inexperienced flyers should fly safely under the guidance of an instruction.**

ⓘ **The GYA460 stabilizes the flight attitude, but this does not mean that any model aircraft can be flown. Use it with a model that was made properly and can fly reliably.**

NAME and FUNCTION of EACH PART

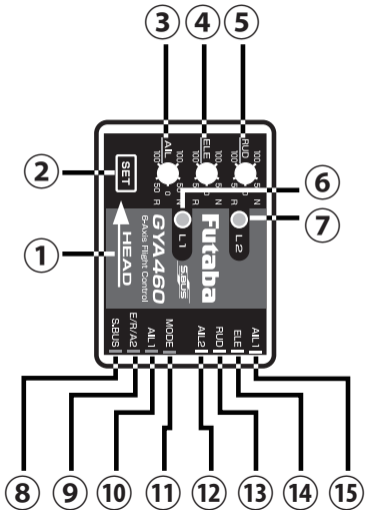

- ① Head direction mark
- ② Set button
- ③ Aileron gyro gain trimmer
- ④ Elevator gyro gain trimmer
- ⑤ Rudder gyro gain trimmer
- ⑥ LED1
- ⑦ LED2
- ⑧ S.BUS input port
- ⑨ ELE/RUD/AIL2 input port
- ⑩ Aileron1 input port
- ⑪ MODE input port
- ⑫ Aileron2 servo PWM output port
- ⑬ Rudder servo PWM output port
- ⑭ Elevator servo PWM output port
- ⑮ Aileron1 servo PWM output port

CONVENTIONAL CONNECTION

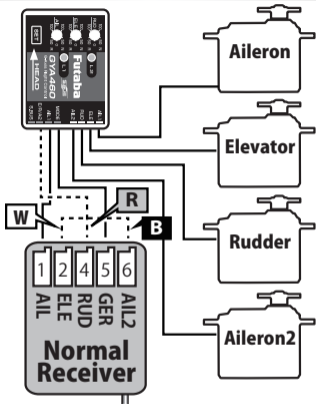

- GYA460 : MODE ⇔ **Extension Cord** ⇔ Rx : CH5
- GYA460 : AIL1 ⇔ **Extension Cord** ⇔ Rx : CH1(AIL)
- GYA460 : E/R/A2 ⇔ **3-Signal Cord** ⇔
White : ELE Red : RUD Black : AIL2

S.BUS CONNECTION

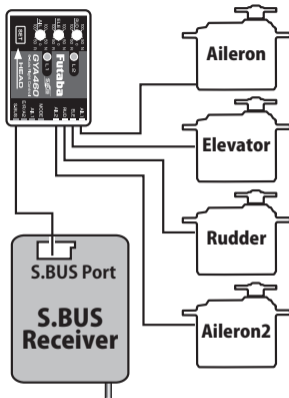

- GYA460 : S.BUS ⇔ **Extension Cord** ⇔ RECEIVER : S.BUS

Transmitter function

1CH : AIL1 2CH : ELE 3CH : THR
4CH : RUD 5CH : GEAR 6CH : AIL2

MOUNTING to the AIRPLANE

Firmly stick the gyro to the chassis with the double sided tape supplied. Install the gyro at a level place near the center of gravity where there is little vibration. It can also be installed at the side or rear of the chassis.

In this case, change the chassis gyro mounting direction setting.

Mount the gyro facing forward in the fuselage.

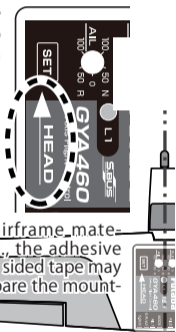

*Depending on the airframe material such as balsa, etc., the adhesive strength of the double sided tape may drop. In this case, prepare the mounting surface well.

*Do not use a product other than the double sided tape supplied. There is the danger of the plane being operated uncontrollably by vibration.

SETTING

1. Transmitter Setting

Assign transmitter CH5 to a 3-position switch, and set the function to "GEAR". This setting enables use of the Beginner MODE, GYRO-OFF MODE, and GYRO-MODE by switching a switch. When you want to change the direction of operation of the switch, perform reverse setting at the transmitter.

5CH Switch

MODE <LED>

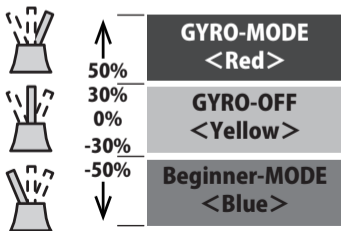

Beginner-MODE

<Blue>

- This mode is suitable for level flight training of beginners.
- Control is implemented by gyro sensor and acceleration sensor.
- The fuselage flight attitude angle is limited to approximately $\pm 80^\circ$.
- When the transmitter sticks (except the throttle) are set to neutral, automatic horizontal level control returns the airplane to the level state.
- The limit angle is linked with transmitter dual rate. For instance, if dual rate is set to 50%, the limit is then restricted to 50%. So maximum angle would be 40 degrees.

GYRO-OFF

<Yellow>

- In this mode, the plane is not controlled by gyro sensor.

GYRO-MODE <Red>

- This mode is suitable for inverted flight and aerobatics.
- The plane is controlled by gyro sensor only.
- Fuselage attitude angle limit and automatic horizontal level control are not active.

◆ When there are no 3-position switch in a transmitter.

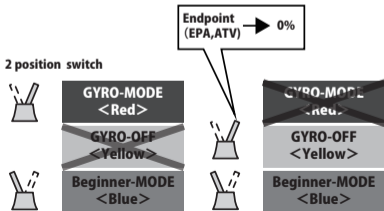

LED1 State

	Status	LED1(L1)	Pattern
1	Start initializes	Green	Blink
2	Initializes completion	Green	Solid
3	No signal	Red	Solid

LED2 State

	Status	LED2(L2)	Pattern
1	To Beginner-MODE	Blue	Solid → OFF
2	To GYRO-OFF-MODE	Yellow	Solid → OFF
3	To GYRO-MODE	Red	Solid → OFF

2. GYRO setting

The parameters can be set by GYA460 SET button.

- ① Turn on the GYA460 power.**
- ② Press the GYA460 SET button for at least 2 seconds to enter the setting mode.**
- ※ When the setting mode is entered, LED1 lights blue.**
- ③ When the SET button is pressed, the color of LED2 changes and the setting is changed.**
- ④ When the SET button is double clicked, the color of LED1 changes and the setting item changes.**
- ⑤ When the SET button is pressed for at least 2 seconds, the setting mode ends.**

Time of GYRO setting LED1 • LED2

Item		Value			
LED1(L1)		LED2(L2)			
		Blue (Default)	Green	Red	Yellow
Green	Tail type	Normal	Flying Wing	—	—
Blue	Install-Direction	Face up	Face down	Face right	Face left

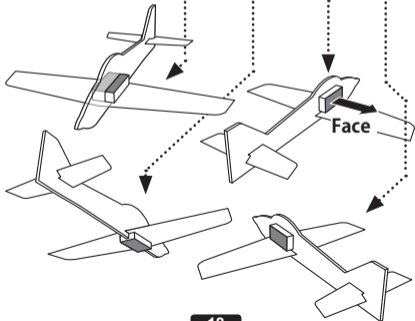

3. Gyro Gain and Direction

Aileron, elevator, and rudder gyro gain adjustment and gyro operating direction are set by flight control trimmer. The center of the scale becomes the gyro low gain position, and gyro gain adjustment and gyro operating direction setting are performed by turning the trimmers to the left or right.

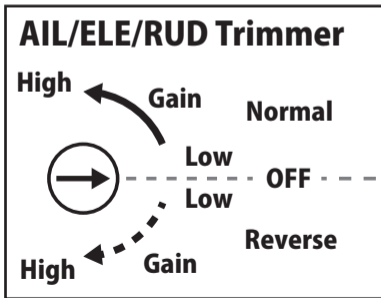

PRE-FLIGHT SETTING

- ① Set the aileron, elevator, and rudder gyro gain trimmers to about 45° .
- ② In the state in which the gyros are operative, move the transmitter sticks and check that each control surface moves in the proper direction. If a control surface moves in the opposite direction of stick operation, set transmitter reverse.
- ③ Without any transmitter input, turn the model on the aileron, elevator, and rudder rotating axis direction and check if each control surface moves in the direction opposite the rotating direction (direction in which the plane returns). If the direction of the steering angle correction rudder is reversed, change the trimmer to 45° of the opposite side.

GYRO DIRECTION CHECK

Tilt the airplane to the right on the ground and check that the rudder operate to the left.

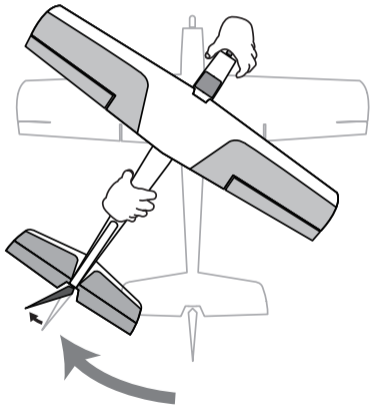

Tilt the airplane to the left on the ground and check that the ailerons operate to the right.

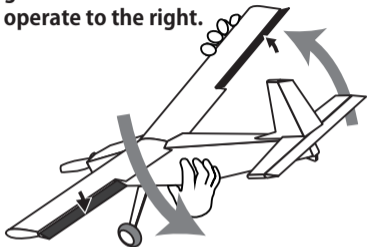

Tilt the airplane to the up on the ground and check that the elevator operate to the down.



FLIGHT SETTING

1. Trim setting

- ① Turn on the power in the **GYRO OFF-MODE** or **GYRO-MODE**.
- ② Fly the plane in the **GYRO OFF-MODE** or **GYRO-MODE** and adjust the trimmers.
- ③ Land the plane and turn off the gyro power.
- ④ Turn on the gyro power again in the **GYRO OFF-MODE** or **GYRO-MODE**. This memorizes the trim position at the gyro.

2. Flight Gain setting

Adjust the gyro gain so that hunting (deflection of the aircraft in small increments) does not occur in the control axis direction. The gyro gain is different depending on the area of the aircraft rudder (aileron/elevator), air speed, and gyro used. Initially try changing the gain in 5% steps. If hunting is excessive, the aircraft may be damaged. Hunting tends to stop when the airspeed is lowered.

※ GYA460 mounting angle

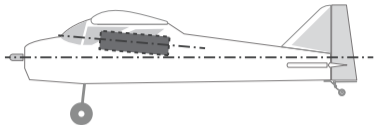

For example, if the gyro is mounted facing upward,

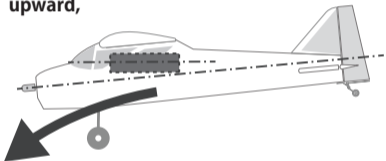

in the beginner mode, the nose will tend to drop.

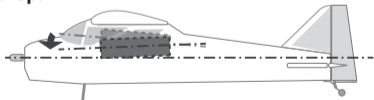

In this case, adjust so that the GYA460 is mounted slightly downward.

TAILLESS WING

This product is compatible with Tailless wing mixing (elevon). The setting method is described below.

● CONNECTION

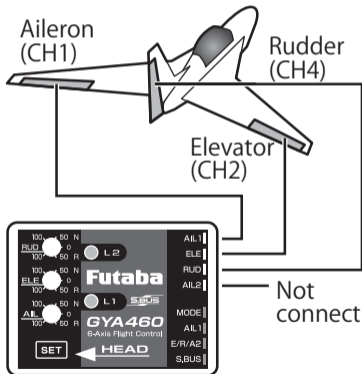

- ① **Set the transmitter in accordance with page 13. Set the transmitter model to normal tail 1 aileron.**
- ※ **Tailless wing mixing is performed at the gyro.**
- ② **Set the gyro to Tailless wing in accordance with pages 17 and 18.**
- ③ **After checking plane operation, make a flight.**

FUTABA CORPORATION

1060 Yabutsuka, Chosei-mura, Chosei-gun, Chiba-ken,
299-4395, Japan

Phone: +61 475 32 6962, Facsimile: +61 475 32 6963

©FUTABA CORPORATION 2015, 5 (1)