

1/10 LUXURY ELECTRIC TRUGGY

XRAY XT4

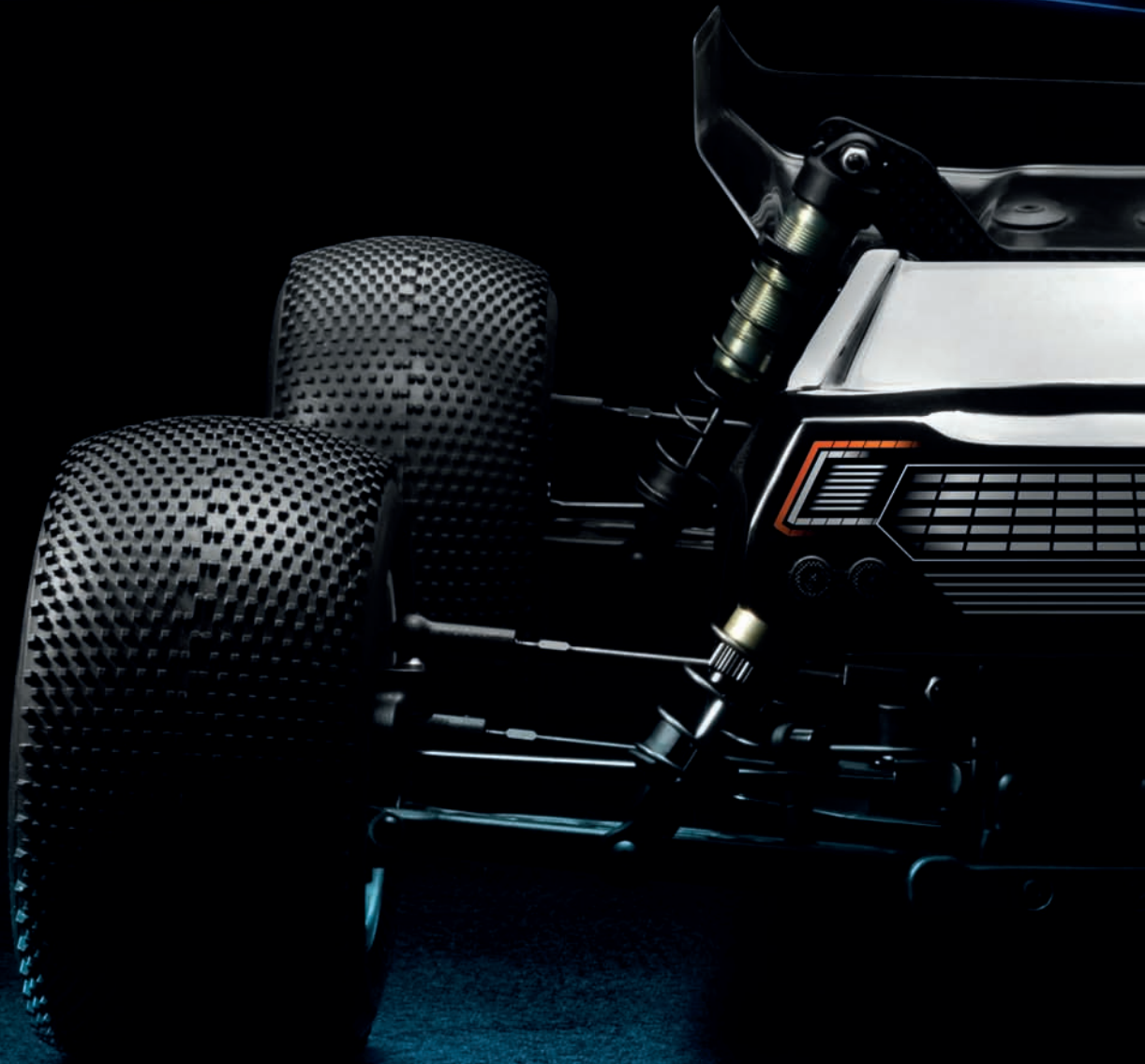

INSTRUCTION MANUAL

BEFORE YOU START

This is a high-competition, high-quality RC car intended for persons aged 16 years and older with previous experience building and operating RC model racing cars. This is not a toy; it is a precision racing model. This model racing car is not intended for use by beginners, inexperienced customers, or by children without direct supervision of a responsible, knowledgeable adult. If you do not fulfill these requirements, please return the kit in unused and unassembled form back to the shop where you have purchased it.

Before building and operating your XRAY, YOU MUST read through all of the operating instructions and instruction manual and fully understand them to get the maximum enjoyment and prevent unnecessary damage.

CUSTOMER SUPPORT

We have made every effort to make these instructions as easy to understand as possible. However, if you have any difficulties, problems, or questions, please do not hesitate to contact the XRAY support team at info@teamxray.com. Also, please visit our Web site at www.teamxray.com to find the latest updates, set-up information, option parts, and many other goodies. We pride ourselves on taking excellent care of our customers.

You can join thousands of XRAY fans and enthusiasts in our online community at: www.teamxray.com

Read carefully and fully understand the instructions before beginning assembly.

Make sure you review this entire manual, download and use set-up book from the web, and examine all details carefully. If for some reason you decide this is not what you wanted or expected, do not continue any further. Your hobby dealer can not accept your kit for return or exchange after it has been partially or fully assembled.

Contents of the box may differ from pictures. In line with our policy of continuous product development, the exact specifications of the kit may vary without prior notice.

XRAY Europe

K Vystavisku 6992
91101 Trenčín
Slovakia, EUROPE
Phone: 421-32-7401100
Fax: 421-32-7401109
E-mail: info@teamxray.com

XRAY USA

RC America, 2030 Century Center Blvd #15
Irving, TX 75062
USA
Phone: (214) 744-2400
Fax: (214) 744-2401
E-mail: xray@rcamerica.com

FAILURE TO FOLLOW THESE INSTRUCTIONS WILL BE CONSIDERED AS ABUSE AND/OR NEGLECT.

SAFETY PRECAUTIONS

Contains:

LEAD (CAS 7439-92-1) ANTIMONY (CAS 7440-36-0)

WARNING: This product contains a chemical known to the state of California to cause cancer and birth defects or other reproductive harm.

CAUTION: CANCER HAZARD

Contains lead, a listed carcinogen. Lead is harmful if ingested. Wash thoroughly after using. DO NOT use product while eating, drinking or using tobacco products. May cause chronic effects to gastrointestinal tract, CNS, kidneys, and blood. MAY CAUSE BIRTH DEFECTS.

When building, using and/or operating this model always wear protective glasses and gloves.

Take appropriate safety precautions prior to operating this model. You are responsible for this model's assembly and safe operation! Please read the instruction manual before building and operating this model and follow all safety precautions. Always keep the instruction manual at hand for quick

reference, even after completing the assembly. Use only genuine and original authentic XRAY parts for maximum performance. Using any third party parts on this model will void guaranty immediately.

Improper operation may cause personal and/or property damage. XRAY and its distributors have no control over damage resulting from shipping, improper construction, or improper usage. XRAY assumes and accepts no responsibility for personal and/or property damages resulting from the use of improper building materials, equipment and operations. By purchasing any item produced by XRAY, the buyer expressly warrants that he/she is in compliance with all applicable federal, state and local laws and regulation regarding the purchase, ownership and use of the item. The buyer expressly agrees to indemnify and hold harmless XRAY for all claims resulting directly or indirectly from the purchase, ownership or use of the product. By the act of assembling or operating this product, the user accepts all resulting liability. If the buyer is not prepared to accept this liability, then he/she should return this kit in new, unassembled, and unused condition to the place of purchase.

IMPORTANT NOTES - GENERAL

- This product is not suitable for children under 16 years of age without the direct supervision of a responsible and knowledgeable adult.
- Carefully read all manufacturers warnings and cautions for any parts used in the construction and use of your model.
- Assemble this kit only in places away from the reach of very small children.
- First-time builders and users should seek advice from people who have building experience in order to assemble the model correctly and to allow the model to reach its performance potential.
- Exercise care when using tools and sharp instruments.
- Take care when building, as some parts may have sharp edges.
- Keep small parts out of reach of small children. Children must not be allowed to put any parts in their mouth, or pull vinyl bag over their head.
- Read and follow instructions supplied with paints and/or cement, if used (not included in kit).
- Immediately after using your model, do NOT touch equipment on the model such as the motor and speed controller, because they generate high temperatures. You may seriously burn yourself seriously touching them.
- Follow the operating instructions for the radio equipment at all times.
- Do not put fingers or any objects inside rotating and moving parts, as this may cause damage or serious injury as your finger, hair, clothes, etc. may get caught.
- Be sure that your operating frequency is clear before turning on or running your model, and never share the same frequency with somebody else at the same time. Ensure that others are aware of the operating frequency you are using and when you are using it.
- Use a transmitter designed for ground use with RC cars. Make sure that no one else is using the same frequency as yours in your operating area. Using the same frequency at the same time, whether it is driving, flying or sailing, can cause loss of control of the RC model, resulting in a serious accident.
- Always turn on your transmitter before you turn on the receiver in the car. Always turn off the receiver before turning your transmitter off.
- Keep the wheels of the model off the ground when checking the operation of the radio equipment.
- Disconnect the battery pack before storing your model.
- When learning to operate your model, go to an area that has no obstacles that can damage your model if your model suffers a collision.
- Remove any sand, mud, dirt, grass or water before putting your model away.
- If the model behaves strangely, immediately stop the model, check and clear the problem.
- To prevent any serious personal injury and/or damage to property, be responsible when operating all remote controlled models.
- The model car is not intended for use on public places and roads or areas where its operation can conflict with or disrupt pedestrian or vehicular traffic.
- Because the model car is controlled by radio, it is subject to radio interference from many sources that are beyond your control. Since radio interference can cause momentary loss of control, always allow a safety margin in all directions around the model in order to prevent collisions.
- Do not use your model:
 - Near real cars, animals, or people that are unaware that an RC car is being driven.
 - In places where children and people gather
 - In residential districts and parks
 - In limited indoor spaces
 - In wet conditions
 - In the street
 - In areas where loud noises can disturb others, such as hospitals and residential areas.
 - At night or anytime your line of sight to the model may be obstructed or impaired in any way.

To prevent any serious personal injury and/or damage to property, please be responsible when operating all remote controlled models.

IMPORTANT NOTES - ELECTRICAL

- Insulate any exposed electrical wiring (using heat shrink tubing or electrical tape) to prevent dangerous short circuits. Take maximum care in wiring, connecting and insulating cables. Make sure cables are always connected securely. Check connectors for if they become loose. And if so, reconnect them securely. Never use RC models with damaged wires. A damaged wire is extremely dangerous, and can cause short-circuits resulting in fire. Please have wires repaired at your local hobby shop.
- Low battery power will result in loss of control. Loss of control can occur due to a weak battery in either the transmitter or the receiver. Weak running battery may also result in an out of control car if your car's receiver power is supplied by the running battery. Stop operation immediately if the car starts to slow down.
- When not using RC model, always disconnect and remove battery.
- Do not disassemble battery or cut battery cables. If the running battery short-circuits, approximately 300W of electricity can be discharged, leading to fire or burns. Never disassemble battery or cut battery cables.
- Use a recommended charger for the receiver and transmitter batteries and follow the instructions correctly. Over-charging, incorrect charging,

or using inferior chargers can cause the batteries to become dangerously hot. Recharge battery when necessary. Continual recharging may damage battery and, in the worst case, could build up heat leading to fire. If battery becomes extremely hot during recharging, please ask your local hobby shop for check and/or repair and/or replacement.

- Regularly check the charger for potential hazards such as damage to the cable, plug, casing or other defects. Ensure that any damage is rectified before using the charger again. Modifying the charger may cause short-circuit or overcharging leading to a serious accident. Therefore do not modify the charger.
- Always unplug charger when recharging is finished.
- Do not recharge battery while battery is still warm. After use, battery retains heat. Wait until it cools down before charging.
- Do not allow any metal part to short circuit the receiver batteries or other electrical/electronic device on the model.
- Immediately stop running if your RC model gets wet as may cause short circuit.
- Please dispose of batteries responsibly. Never put batteries into fire.

R/C & BUILDING TIPS

- Make sure all fasteners are properly tightened. Check them periodically.
- Make sure that chassis screws do not protrude from the chassis.
- For the best performance, it is very important that great care is taken to ensure the free movement of all parts.
- Clean all ball-bearings so they move very easily and freely.
- Tap or pre-thread the plastic parts when threading screws.
- Self-tapping screws cut threads into the parts when being tightened. Do not use excessive force when tightening the self-tapping screws because you may strip out the thread in the plastic. We recommended you stop tightening a screw when you feel some resistance.
- Ask your local hobby shop for any advice.

Please support your local hobby shop. We at XRAY Model Racing Cars support all local hobby dealers. Therefore we ask you, if at all possible, to purchase XRAY products at your hobby dealer and give them your support like we do. If you have difficulty finding XRAY products, please check out www.teamxray.com to get advice, or contact us via email at info@teamxray.com, or contact the XRAY distributor in your country.

WARRANTY

XRAY guarantees this model kit to be free from defects in both material and workmanship within 30 days of purchase. The total monetary value under warranty will in no case exceed the cost of the original kit purchased. This warranty does not cover any components damaged by use or modification or as a result of wear. Part or parts missing from this kit must be reported within 30 days of purchase. No part or parts will be sent under warranty without proof of purchase. Should you find a defective or missing part, contact the local distributor. Service and customer support will be provided through local hobby store where you have purchased the kit, therefore make sure to purchase any XRAY products at your local hobby store. This model racing car is considered to be a high-performance racing vehicle. As such this vehicle will be used in an extreme range of conditions and situations, all which may cause premature wear or failure of any component. XRAY has no control over usage of vehicles once they leave the dealer, therefore XRAY can only offer warranty against all manufacturer's defects in materials, workmanship, and assembly at point of sale and before use. No warranties are expressed or implied that cover damage caused by what is considered normal use, or cover or imply how long any model cars' components or electronic components will last before requiring replacement.

Due to the high performance level of this model car you will need to periodically maintain and replace consumable components. Any and all warranty coverage will not cover replacement of any part or component damaged by neglect, abuse, or improper or unreasonable use. This includes

but is not limited to damage from crashing, chemical and/or water damage, excessive moisture, improper or no maintenance, or user modifications which compromise the integrity of components. Warranty will not cover components that are considered consumable on RC vehicles. XRAY does not pay nor refund shipping on any component sent to XRAY or its distributors for warranty. XRAY reserves the right to make the final determination of the warranty status of any component or part.

Limitations of Liability

XRAY makes no other warranties expressed or implied. XRAY shall not be liable for any loss, injury or damages, whether direct, indirect, special, incidental, or consequential, arising from the use, misuse, or abuse of this product and/or any product or accessory required to operate this product. In no case shall XRAY's liability exceed the monetary value of this product.

Take adequate safety precautions prior to operating this model. You are responsible for this model's assembly and safe operation.

Disregard of the any of the above cautions may lead to accidents, personal injury, or property damage. XRAY MODEL RACING CARS assumes no responsibility for any injury, damage, or misuse of this product during assembly or operation, nor any addictions that may arise from the use of this product.

All rights reserved.

QUALITY CERTIFICATE

XRAY MODEL RACING CARS uses only the highest quality materials, the best compounds for molded parts and the most sophisticated manufacturing processes of TQM (Total Quality Management). We guarantee that all parts of a newly-purchased kit are manufactured with the highest regard to quality. However, due to the many factors inherent in model racecar competition, we

















cannot guarantee any parts once you start racing the car. Products which have been worn out, abused, neglected or improperly operated will not be covered under warranty.

We wish you enjoyment of this high-quality and high-performance RC car and wish you best success on the track!

In line with our policy of continuous product development, the exact specifications of the kit may vary. In the unlikely event of any problems with your new kit, you should contact the model shop where you purchased it, quoting the part number.

We do reserve all rights to change any specification without prior notice. All rights reserved.







SYMBOLS USED

<p>Part bags used</p> 	<p>Assemble in the specified order</p> 	<p>Assemble left and right sides the same way</p> 	<p>Pay attention here</p> 	<p>Assemble as many times as specified (here twice)</p> 	<p>Apply threadlock</p> 	<p>Apply CA glue</p> 	<p>Apply oil</p> 
<p>Scale</p> 	<p>Apply grease</p> 	<p>Optional parts</p> 	<p>Ensure smooth non-binding movement</p> 	<p>Tighten screw gently</p> 	<p>Completed assembly</p> 	<p>Detail</p> 	<p>Apply cleaner</p> 













TOOLS REQUIRED

<p>Scissors (HUDY #188990)</p> 	<p>Special Tool for turnbuckles & nuts (HUDY #181090)</p> 	<p>Turnbuckle Wrench 3mm (HUDY #181030)</p> 	<p>Pocket Hobby Knife (HUDY #188981)</p> 	<p>Side Cutters (HUDY #189010)</p> 	<p>Combination Pliers (HUDY #189020)</p> 	<p>Professional Multi Tool (HUDY #183011)</p> 
<p>Tweezer</p> 	<p>HUDY TOOLS:</p>   			 		

ITEMS INCLUDED

<p>HUDY Premium Silicone Oils Oil 450cSt (#106345)</p> 	<p>HUDY Premium Silicone Oils Oil 650cSt (#106365)</p> 	<p>HUDY Premium Silicone Oils Oil 10.000cSt (#106510)</p> 	<p>HUDY Premium Silicone Oils Oil 30.000cSt (#106530)</p> 	<p>HUDY Premium Silicone Oils Oil 100.000cSt (#106610)</p> 	<p>Graphite Grease (HUDY #106210)</p> 
--	--	---	---	--	---

EQUIPMENT REQUIRED

<p>Transmitter</p> 	<p>Receiver</p> 	<p>Steering Servo</p> 	<p>Electric Motor & Pinion Gear with Set-screw</p> 	<p>Bearing Oil (HUDY #106230)</p> 	<p>CA glue</p> 
<p>Speed Controller</p> 	<p>LiPo Battery</p> 	<p>Lexan™ Paint</p> 	<p>Battery Charger</p> 	<p>Double-sided Tape (HUDY #107875)</p> 	<p>Tires & Inserts</p> 

NOT INCLUDED

Set-up Book

To ensure that you always have access to the most up-to-date version of the HUDY Set-up Book, you can download it from the HUDY website at [www.hudy.net]. By offering this online version instead of including a hardcopy printed version in kits, you will always be assured of having the most current updated version.



XRAY offers wide range of optional tuning parts which are listed in tables like these. Please refer to the exploded view of each main section to verify which part is included in the kit while all other parts are available only as an optional part and must be purchased separately.



SAMPLE OF OPTIONAL PARTS

#32XXXX	TYPE	OPTION 1
#32XXXX	TYPE	OPTION 2
#32XXXX	TYPE	INCLUDED
#32XXXX	TYPE	OPTION 3

COLOR INDICATIONS

At the beginning of each section is an exploded view of the parts to be assembled. There is also a list of all the parts and part numbers that are related to the assembly of that section.

The part descriptions are color-coded to make it easier for you to identify the source of a part. Here are what the different colors mean:

364910

STYLE A - indicates parts that are included in the bag marked for the section.

361105

STYLE B - indicates parts that are included in the box.

364902

STYLE C - indicates parts that are already assembled from previous steps.

XB4 TECH TIPS

TIP DRIVE SHAFT PIN SERVICING

To enjoy the longest possible lifespan of the drive shafts and diff outdrives, it is extremely important to properly service the drive shaft pins. Inspect the pins after every 3 hours of runtime. If the pins show any wear, replace them with new pins.



Do not use drive shafts when the pins are worn.

Press out the worn pins.

Press in new pins and regularly inspect for wear.



For quick & easy drive pin replacements use #106000 HUDY Drive Pin Replacement Tool together with #106036 Ejector Pivot Pin & Alternating Pivot 2.5mm.



To replace the worn pins use only premium HUDY drive pins (#106051 3.0mm dia x 10mm length) (#106053 2.5mm dia x 10mm length)

TIP GRAPHITE PARTS PREPARATION

Follow this Tech Tip to prepare the graphite parts. Sand the edges with sandpaper, and then seal the edges with CA glue to reinforce them and help prevent delamination.

Prepare all XT4 Graphite Parts:

- Front shock tower
- Rear shock tower

Fine sandpaper

Use fine sandpaper to sand smooth the edges of all graphite parts.

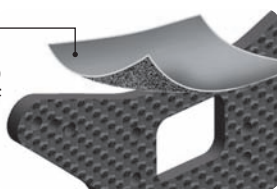

Apply CA glue to all edges of the graphite parts.

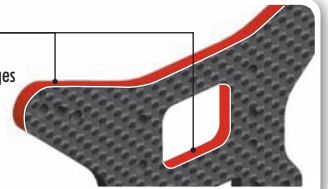

1. FRONT & REAR DIFFERENTIAL



BEVEL GEARS		
#364935	GRAPHITE	OPTION
#364945	ALU	OPTION
#364955	STEEL	INCLUDED

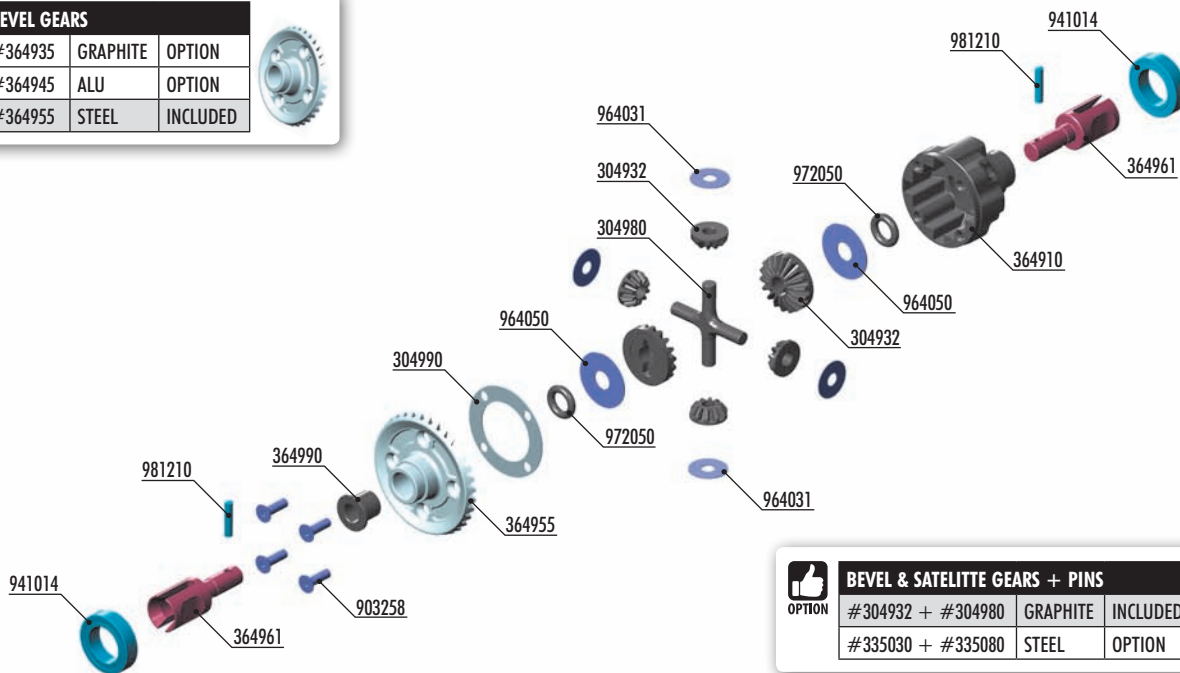

BEVEL & SATELLITE GEARS + PINS		
#304932 + #304980	GRAPHITE	INCLUDED
#335030 + #335080	STEEL	OPTION



BAG



- 304932 GRAPHITE GEAR DIFF BEVEL & SATELLITE GEARS (2 + 4)
- 304980 COMPOSITE GEAR DIFF CROSS PIN
- 304990 DIFF GASKET (4)
- 364902 GEAR DIFFERENTIAL FOR 2.5MM PIN - SET
- 364910 COMPOSITE GEAR DIFFERENTIAL CASE
- 364955 STEEL DIFFERENTIAL BEVEL GEAR 35T
- 364961 GEAR DIFF OUTDRIVE ADAPTER FOR 2.5MM PIN - HUDY SPRING STEEL™ (2)

- 364990 COMPOSITE BEVEL GEAR BUSHING (2)
- 903258 HEX SCREW SFH M2.5x8 (10)
- 941014 BALL-BEARING 10x15x4 RUBBER SEALED - GREASE (2)
- 964031 WASHER S 3.5x10x0.2 (10)
- 964050 WASHER S 5x15x0.3 (10)
- 972050 SILICONE O-RING 5x2 (10)
- 981210 PIN 2x10 (10)

- 964050
S 5x15x0.3
- 972050
O 5x2
- 981210
P 2x10

2x

STEP 4 5 DETAIL

DO NOT USE for optional ALU or GRAPHITE gears

#106210 HUDY GRAPHITE GREASE

- 964050
S 5x15x0.3
- 972050
O 5x2
- 981210
P 2x10

2x

NOTE ORIENTATION

STEP 4 DETAIL
Use tweezers to insert pin

#106210 HUDY GRAPHITE GREASE

CUTAWAY VIEW

1. FRONT & REAR DIFFERENTIAL



964031
S 3.5x10x0.2

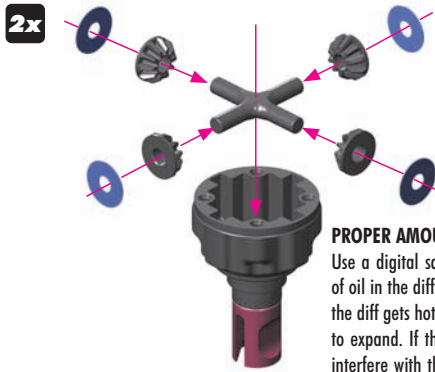

PROPER AMOUNT OF OIL IN THE DIFFS

Use a digital scale to measure the exact amount of oil in the diff. Remember that during operation the diff gets hotter and the heat may allow the oil to expand. If there is too much oil inside it may interfere with the diff operation and damage the internal gears.

Front diff

Silicone oil **30.000cSt**
Fill just above the cross-pins.

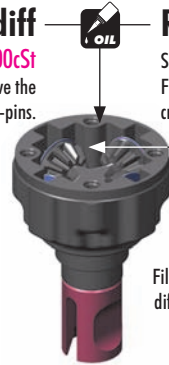

Rear diff

Silicone oil **10.000cSt**
Fill just above the cross-pins.

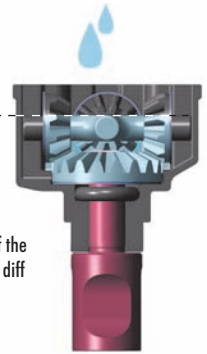

Fill differential up to the top of the diff cross-pins. **DO NOT** fill the diff to the top of the housing.

TO ENSURE YOU HAVE THE SAME AMOUNT OF OIL FROM REBUILD TO REBUILD, DO THE FOLLOWING:



1 Put the diff (without oil) on the scale and check the weight (approximately 9.80g)

#107865
HUDY Ultimate Digital Pocket
Scale 300g ± 0.01g

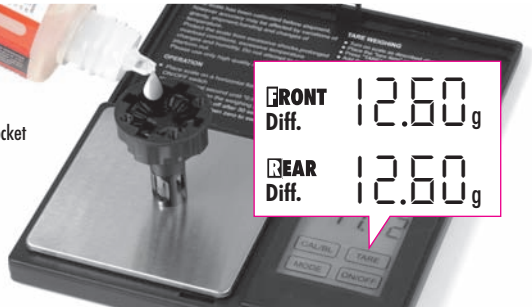

2 Slowly pour oil into the diff and watch the weight.

FRONT	Diff.	11.40g + 1.20g	=	12.60g
REAR	Diff.	11.40g + 1.20g	=	12.60g

30.000cSt

10.000cSt

TIPS FOR DIFFERENTIALS

TIP

FRONT DIFFERENTIAL

LOW TRACTION 20 000cSt (HUDY #106520)
MEDIUM-HIGH TRACTION 30 000cSt (HUDY #106530)
SUPER-HIGH TRACTION 40 000cSt (HUDY #106540)

NOTE:

Softer oil increases steering, harder oil increases stability.

REAR DIFFERENTIAL

LOW TRACTION 5 000cSt (HUDY #106450)
MEDIUM-HIGH TRACTION 10 000cSt (HUDY #106510)
SUPER-HIGH TRACTION 15 000cSt (HUDY #106515)

NOTE:

Softer oil increases rear traction, harder oil increases on-power steering.

TIP

SET-UP BOOK

DIFFERENTIAL OIL



903258
SFH M2.5x8



941014
BB 10x15x4

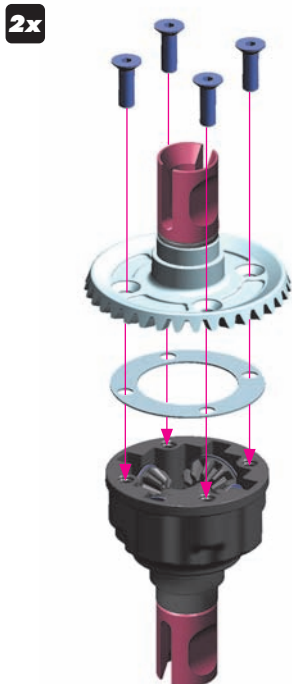

2x Tighten the screws equally but do NOT tighten them completely.

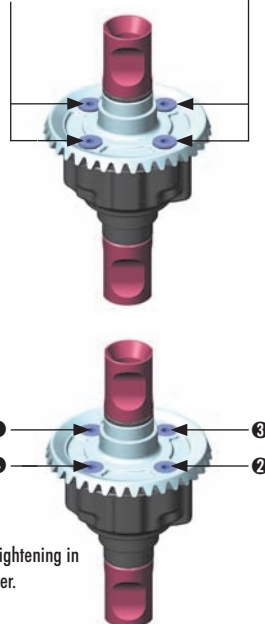

Finish tightening in this order.

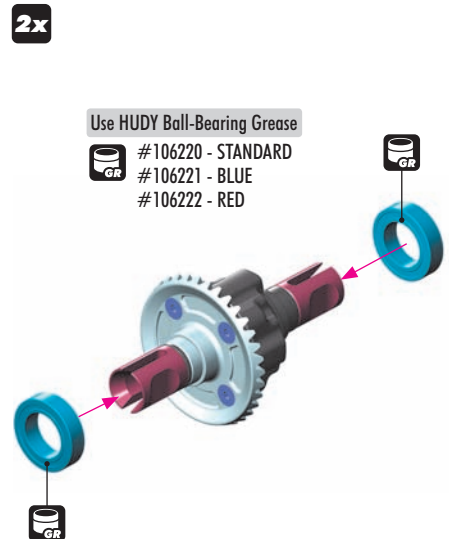

Use HUDY Ball-Bearing Grease

#106220 - STANDARD
#106221 - BLUE
#106222 - RED

1. GEAR CENTER DIFFERENTIAL

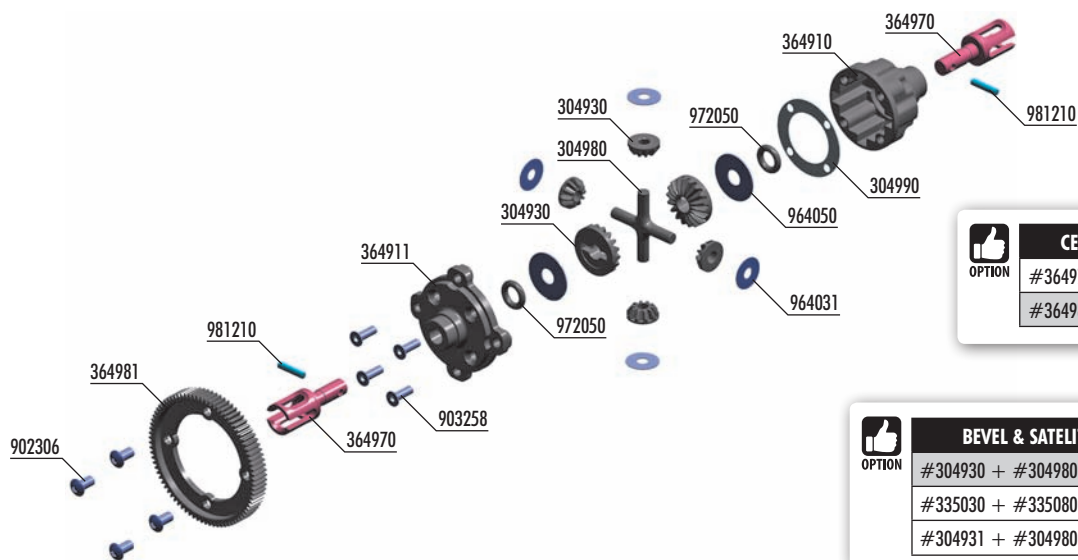

CENTER DIFF SPUR GEARS			
OPTION	#364978	78T/48	OPTION
	#364981	81T/48	INCLUDED

BEVEL & SATELLITE GEARS + PINS			
OPTION	#304930 + #304980	COMPOSITE	INCLUDED
	#335030 + #335080	STEEL	OPTION
	#304931 + #304980	GRAPHITE	OPTION

BAG

01.3

- 304930 COMPOSITE GEAR DIFF BEVEL & SATELLITE GEARS (2+4)
- 304980 COMPOSITE GEAR DIFF CROSS PIN
- 304990 DIFF GASKET (4)
- 364901 GEAR CENTER DIFFERENTIAL - SET
- 364910 COMPOSITE GEAR DIFFERENTIAL CASE
- 364911 COMPOSITE CENTER GEAR DIFFERENTIAL ADAPTER
- 364970 CENTER DIFF OUTDRIVE ADAPTER - HUDY SPRING STEEL™ (2)
- 364981 COMPOSITE CENTER DIFF SPUR GEAR 81T / 48

- 902306 HEX SCREW SH M3x6 (10)
- 903258 HEX SCREW SFH M2.5x8 (10)
- 964031 WASHER S 3.5x10x0.2 (10)
- 964050 WASHER S 5x15x0.3 (10)
- 972050 SILICONE O-RING 5x2 (10)
- 981210 PIN 2x10 (10)



964050
S 5x15x0.3



972050
O 5x2



981210
P 2x10

01.2

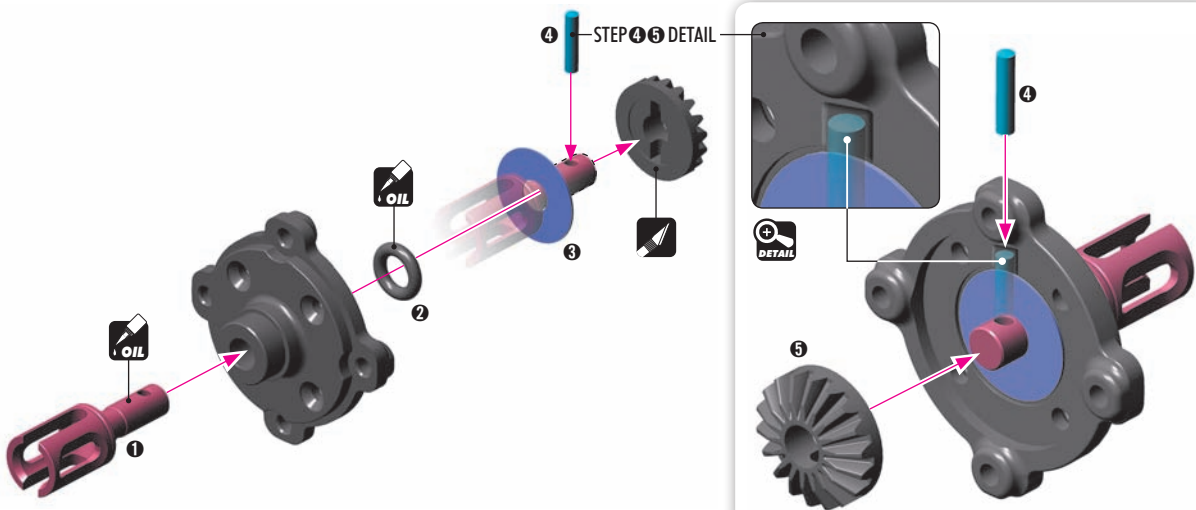

964050
S 5x15x0.3



972050
O 5x2



981210
P 2x10

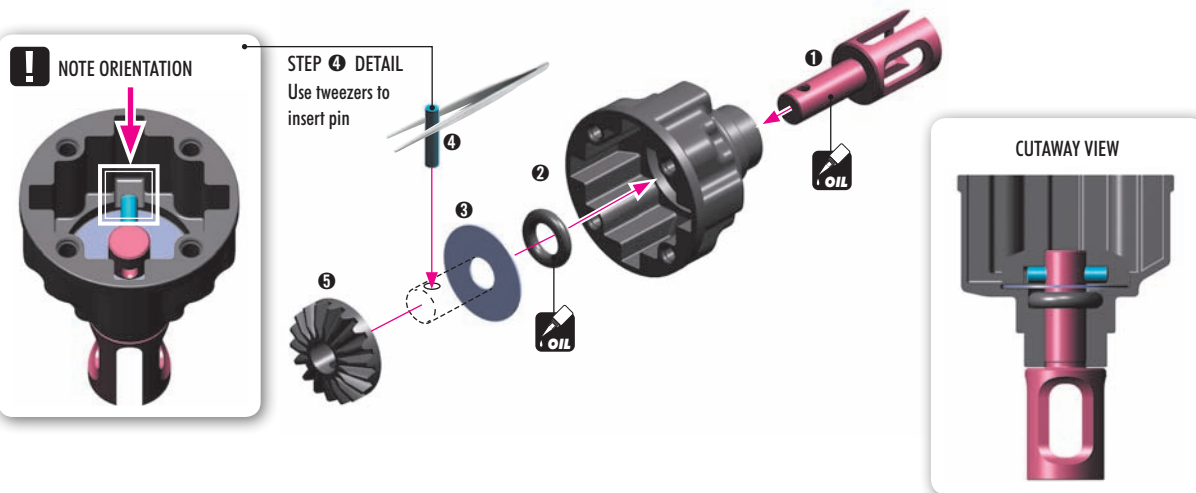

1. GEAR CENTER DIFFERENTIAL



964031
S 3.5x10x0.2

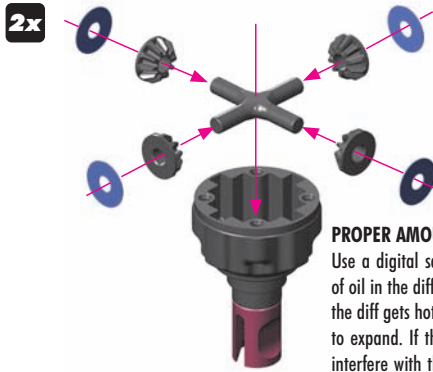

PROPER AMOUNT OF OIL IN THE DIFFS

Use a digital scale to measure the exact amount of oil in the diff. Remember that during operation the diff gets hotter and the heat may allow the oil to expand. If there is too much oil inside it may interfere with the diff operation and damage the internal gears.



Center diff

Silicone oil 100.000cSt
Fill just above the cross-pins.



Fill differential up to the top of the diff cross-pins. DO NOT fill the diff to the top of the housing.

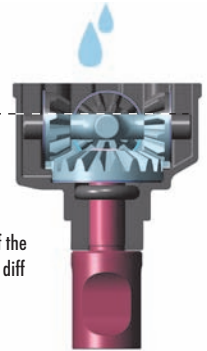

TO ENSURE YOU HAVE THE SAME AMOUNT OF OIL FROM REBUILD TO REBUILD, DO THE FOLLOWING:



#107865
HUDY Ultimate Digital Pocket
Scale 300g ± 0.01g



1 Put the diff (without oil) on the scale and check the weight (approximately 9.80g)

CENTER Diff. 11.00g + 1.50g = 12.50g

2 Slowly pour oil into the diff and watch the weight.

TIP FOR CENTER DIFFERENTIAL

LOW TRACTION	50.000cSt (HUDY #106550)
MEDIUM TRACTION	100.000cSt (HUDY #106610)
HIGH TRACTION	500.000cSt (HUDY #106650)

NOTE:

Softer oil increases steering, harder oil increases stability.

SET-UP BOOK

DIFFERENTIAL OIL

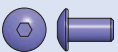

902306
SH M3x6



903258
SFH M2.5x6

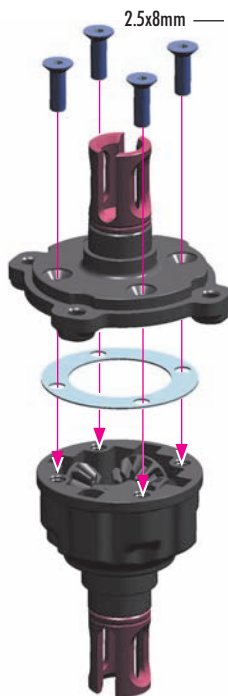

2.5x8mm — Tighten the screws equally but do NOT tighten them completely.

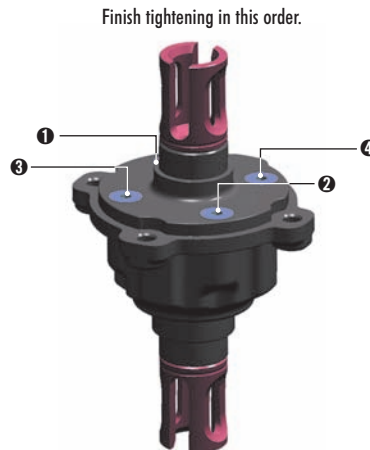

Finish tightening in this order.

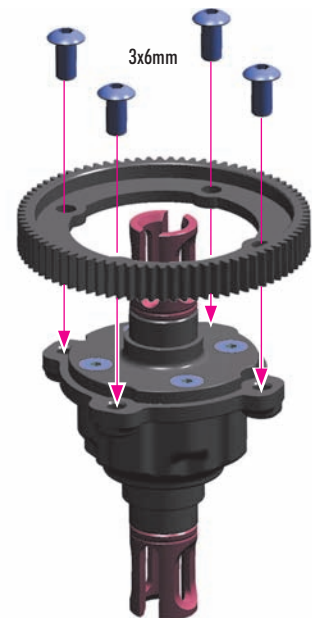

2. REAR CENTRAL TRANSMISSION

MARKED "R"

IMPORTANT REAR BLOCK

XRAY BALL-BEARINGS

OPTION	#359050	5x10x4	GREASE	OPTION
	#940510	5x10x4	OIL	INCLUDED
	#940814	8x14x4	GREASE	OPTION
	#940815	8x14x4	OIL	INCLUDED

DRIVE SHAFT COLLARS

OPTION	#365470	COMPOSITE	INCLUDED
	#365471-K	ALU - BLACK	OPTION
	#365471-O	ALU - ORANGE	OPTION

BEVEL DRIVE GEARS

OPTION	#365114	GRAPHITE	OPTION
	#365134	STEEL	OPTION

CENTRAL SHAFT UNIVERSAL JOINTS

+	#365440		OPTION
---	---------	--	--------

BAG

02

- | | | | |
|--------|--|--------|---|
| 362003 | DIFF BULKHEAD BLOCK SET REAR | 902310 | HEX SCREW SH M3x10 (10) |
| 363083 | XT4 GRAPHITE SHOCK TOWER REAR 3.5MM | 940510 | BALL-BEARING 5x10x4 RUBBER SEALED - OIL (2) |
| 365124 | STEEL BEVEL DRIVE GEAR 14T | 940815 | BALL-BEARING 8x14x4 RUBBER SEALED - OIL (2) |
| 365230 | DRIVE SHAFT COUPLING - HUDY SPRING STEEL™ | 980210 | PIN 2x10 (10) |
| 365427 | CENTRAL DRIVE SHAFT 105MM - HUDY SPRING STEEL™ | 981208 | PIN 2x8 (10) |
| 365442 | CENTRAL SHAFT UNIVERSAL JOINT | 364902 | GEAR DIFFERENTIAL FOR 2.5MM PIN - SET |
| 365470 | COMPOSITE DRIVE SHAFT SAFETY COLLAR - V2 (3) | 364955 | STEEL DIFFERENTIAL BEVEL GEAR 35T |
| 902306 | HEX SCREW SH M3x6 (10) | | |

980210
P 2x10

! DRIVE SHAFT COVER CAPS
Lubricate the drive shaft connecting joint properly so the drive shaft turns freely. In the event that not enough grease is used, the connecting pin may lock and may even, in extreme situations, push through the drive shaft cover cap.

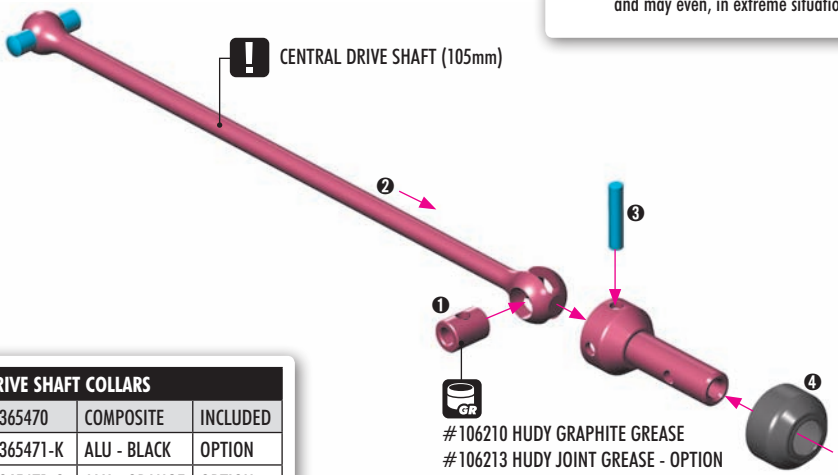

DRIVE SHAFT COLLARS

OPTION	#365470	COMPOSITE	INCLUDED
	#365471-K	ALU - BLACK	OPTION
	#365471-O	ALU - ORANGE	OPTION

2. REAR CENTRAL TRANSMISSION

902306
SH M3x6

940510
BB 5x10x4

940815
BB 8x14x4

981208
P 2x8

Marked "R"

REAR BLOCK

Bearing with BLUE rubber covers

Bearing Oil (HUDY #106230)

5x10x4mm

NOTE ORIENTATION

Bearing Oil (HUDY #106230)

8x14x4mm

GRAPHITE GREASE (HUDY #106210)

THREAD LOCK

OPTION	XRAY BALL-BEARINGS	SIZE	LUBRICATION	STATUS
OPTION	#359050	5x10x4	GREASE	OPTION
	#940510	5x10x4	OIL	INCLUDED
	#940814	8x14x4	GREASE	OPTION
	#940815	8x14x4	OIL	INCLUDED

902310
SH M3x10

FRONT

NOTE ORIENTATION

REAR DIFF 10.000cSt

REAR

902310
SH M3x10

ALTERNATIVE 2
SHOCKS MOUNTED BEHIND REAR SHOCK TOWER
DO NOT USE FOR BASIC SET-UP

Follow the TECH TIP on page 5 to prepare graphite parts **TIP**

ALTERNATIVE 1
SHOCKS MOUNTED IN FRONT OF REAR SHOCK TOWER
(INITIAL SETTING)

REAR

FRONT

NOTE
Alternatives shock mounted follow page 39 / step 2 and 3.

2. FRONT CENTRAL TRANSMISSION

MARKED "F"

IMPORTANT FRONT BLOCK

XRAY BALL-BEARINGS

OPTION	#359050	5x10x4	GREASE	OPTION
	#940510	5x10x4	OIL	INCLUDED
	#940814	8x14x4	GREASE	OPTION
	#940815	8x14x4	OIL	INCLUDED

DRIVE SHAFT COLLARS

OPTION	#365470	COMPOSITE	INCLUDED
	#365471-K	ALU - BLACK	OPTION
	#365471-O	ALU - ORANGE	OPTION

BEVEL DRIVE GEARS

OPTION	#365114	GRAPHITE	OPTION
	#365134	STEEL	OPTION

CENTRAL SHAFT UNIVERSAL JOINTS

	#365440		OPTION
--	---------	--	--------

<p>BAG</p>	362002	DIFF BULKHEAD BLOCK SET FRONT	902310	HEX SCREW SH M3x10 (10)
	362084	XT4 GRAPHITE SHOCK TOWER FRONT 3.5MM	940510	BALL-BEARING 5x10x4 RUBBER SEALED - OIL (2)
	365124	STEEL BEVEL DRIVE GEAR 14T	940815	BALL-BEARING 8x14x4 RUBBER SEALED - OIL (2)
	365230	DRIVE SHAFT COUPLING - HUDY SPRING STEEL™	980210	PIN 2x10 (10)
	365426	CENTRAL DRIVE SHAFT 72MM - HUDY SPRING STEEL™	981208	PIN 2x8 (10)
	365442	CENTRAL SHAFT UNIVERSAL JOINT	364902	GEAR DIFFERENTIAL FOR 2.5MM PIN - SET
	365470	COMPOSITE DRIVE SHAFT SAFETY COLLAR - V2 (3)	364955	STEEL DIFFERENTIAL BEVEL GEAR 35T
	902306	HEX SCREW SH M3x6 (10)		

980210
P 2x10

! DRIVE SHAFT COVER CAPS
Lubricate the drive shaft connecting joint properly so the drive shaft turns freely. In the event that not enough grease is used, the connecting pin may lock and may even, in extreme situations, push through the drive shaft cover cap.

! CENTRAL DRIVE SHAFT (72mm)

1. Grease application point
2. Drive shaft assembly
3. Pin insertion
4. Cap installation

#106210 HUDY GRAPHITE GREASE
#106213 HUDY JOINT GREASE - OPTION

DRIVE SHAFT COLLARS

OPTION	#365470	COMPOSITE	INCLUDED
	#365471-K	ALU - BLACK	OPTION
	#365471-O	ALU - ORANGE	OPTION

2. FRONT CENTRAL TRANSMISSION

902306
SH M3x6

940510
BB 5x10x4

940815
BB 8x14x4

981208
P 2x8

Bearing with BLUE rubber covers

Bearing Oil (HUDY #106230)

5x10x4mm

8x14x4mm

Bearing Oil (HUDY #106230)

GRAPHITE GREASE (HUDY #106210)

THREAD LOCK

NOTE ORIENTATION

Marked "F"

XRAY BALL-BEARINGS				
OPTION			GREASE	OPTION
#359050	5x10x4			
#940510	5x10x4	OIL		INCLUDED
#940814	8x14x4		GREASE	OPTION
#940815	8x14x4		OIL	INCLUDED

902310
SH M3x10

REAR

NOTE ORIENTATION

FRONT DIFF 30.000cst

FRONT

902310
SH M3x10

REAR

NOTE ORIENTATION

FRONT

TIP

Follow the TECH TIP on page 5 to prepare graphite parts

3. REAR SUSPENSION

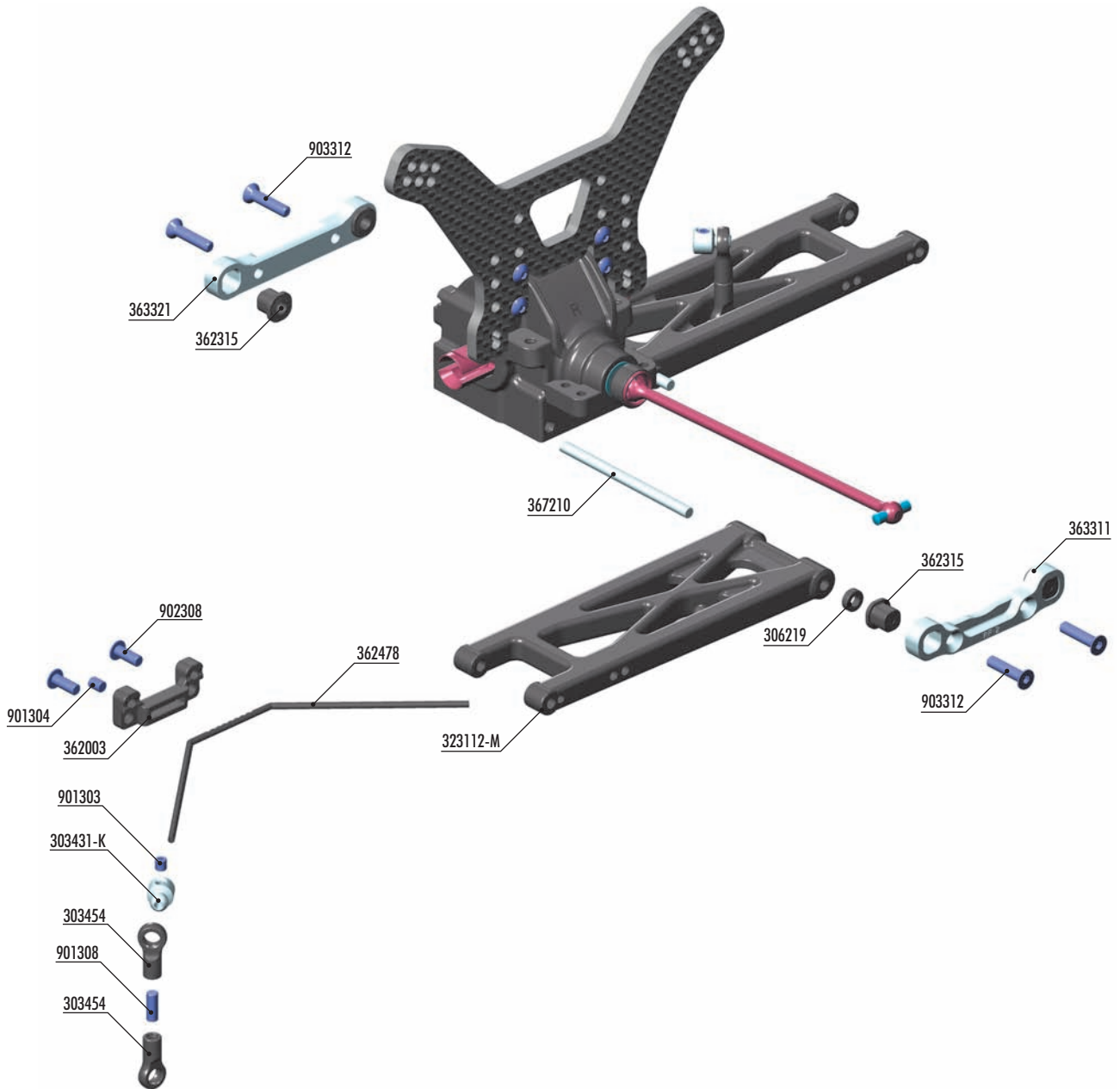

REAR SUSPENSION ARMS			
OPTION	#323112-M	MEDIUM	INCLUDED
	#323112-H	HARD	OPTION
	#323112-G	GRAPHITE	OPTION

OPTION #363313
BRASS REAR LOWER SUSPENSION
HOLDER SET +2 - RR + RF

ANTI-ROLL BARS			
OPTION	#362470	1.0mm	OPTION
	#362471	1.1mm	OPTION
	#362472	1.2mm	OPTION
	#362473	1.3mm	OPTION
	#362474	1.4mm	OPTION
	#362476	1.6mm	OPTION
	#362478	1.8mm	INCLUDED
	#362480	2.0mm	OPTION



- 303431-K ALU 4.9MM BALL END - BLACK (2)
- 303454 BALL JOINT 4.9MM - OPEN (4)
- 306219 COMPOSITE SET OF SERVO SHIMS (4)
- 362003 DIFF BULKHEAD BLOCK SET REAR
- 362315 ECCENTRIC BUSHING SET (2)
- 362478 ANTI-ROLL BAR 1.8 MM
- 323112-M XT4 COMPOSITE SUSPENSION ARM REAR LOWER - MEDIUM
- 363311 ALU REAR LOWER SUSP. HOLDER +2 - FRONT - 7075 T6 (5MM)
- 363321 ALU REAR LOWER SUSP. HOLDER +2 - REAR - 7075 T6 (5MM)

- 367210 SUSPENSION PIVOT PIN (2)
- 901303 HEX SCREW SB M3x3 (10)
- 901304 HEX SCREW SB M3x4 (10)
- 901308 HEX SCREW SB M3x8 (10)
- 902308 HEX SCREW SH M3x8 (10)
- 903312 HEX SCREW SFH M3x12 (10)

3. REAR SUSPENSION



306219
SHIM 3x6x2



903312
SFH M3x12

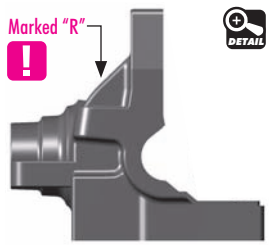

REAR SUSPENSION ARMS		
#323112-M	MEDIUM	INCLUDED
#323112-H	HARD	OPTION
#323112-G	GRAPHITE	OPTION

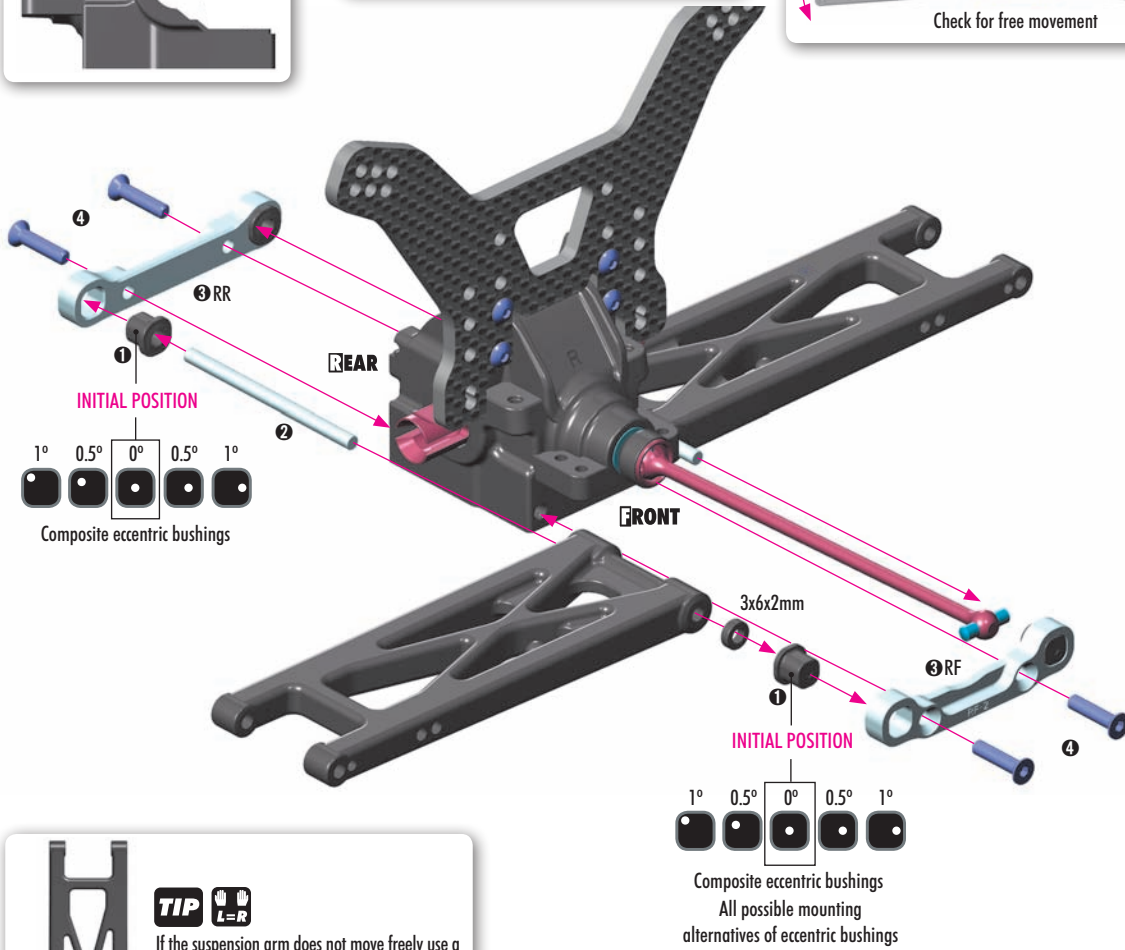

TIP If the suspension arm does not move freely use a HUDY Arm Reamer to size the holes of the arms

Arm Reamer 3.0mm (HUDY #107633)

SET-UP BOOK

TOE-IN
ANTI-SQUAT
ROLL CENTER
TRACK-WIDTH

ECCENTRIC BUSHINGS HAVE TWO DIFFERENT OFFSETS FROM THE CENTER.

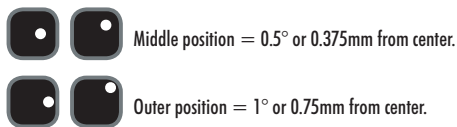

The XRAY rear alu lower suspension holders provide great range of adjustment for the rear suspension. Using different combinations of eccentric bushings, fine adjustment of rear anti-squat, rear toe-in, rear roll center, and rear track-width can be obtained. For more information about the influence of rear anti-squat, rear toe-in, rear roll center and rear track width on car handling, please refer to HUDY Set-up Book (#209100).

ANTI-SQUAT		
RR	RF	(°)
		= 2°
		= 3°
		= 1°
		= 3°
		= 2°
		= 4°
		= 1°
		= 2°
		= 0°

ROLL CENTER		
RR	RF	(mm)
		= +0.75mm
		= 0mm
		= -0.75mm

TRACK-WIDTH		
RR	RF	(mm)
		= +1.5mm
		= 0mm
		= -1.5mm

TOE-IN		
RR	RF	(°)
		= 3°
		= 4°
		= 2°
		= 2°
		= 3°
		= 1°
		= 4°
		= 5°
		= 3°

The tables describe the amounts of adjustment using the center and outside positions of the eccentric bushings. The middle position eccentric bushings allow for finer adjustment increments.

Example:



3. REAR SUSPENSION

901308
SB M3x8

2x
L=R

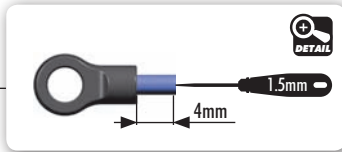
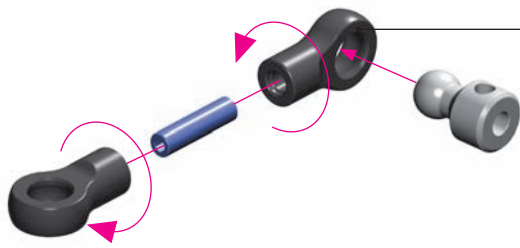

901303
SB M3x3

901304
SB M3x4

902308
SH M3x8

ANTI-ROLL BARS			
OPTION	#362470	1.0mm	OPTION
	#362471	1.1mm	OPTION
	#362472	1.2mm	OPTION
	#362473	1.3mm	OPTION
	#362474	1.4mm	OPTION
	#362476	1.6mm	OPTION
	#362478	1.8mm	INCLUDED
	#362480	2.0mm	OPTION

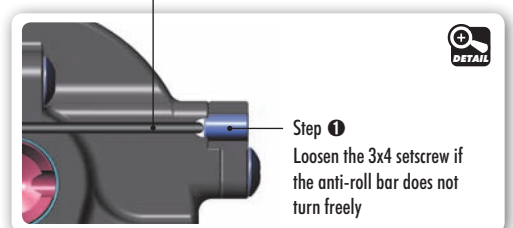
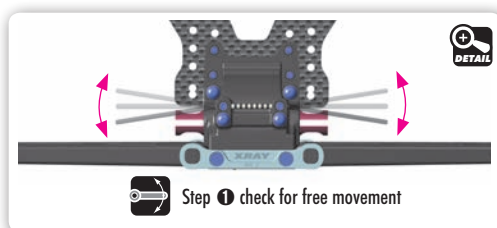
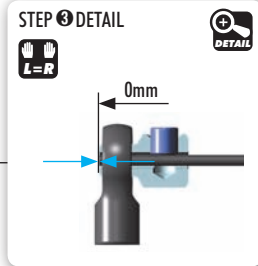
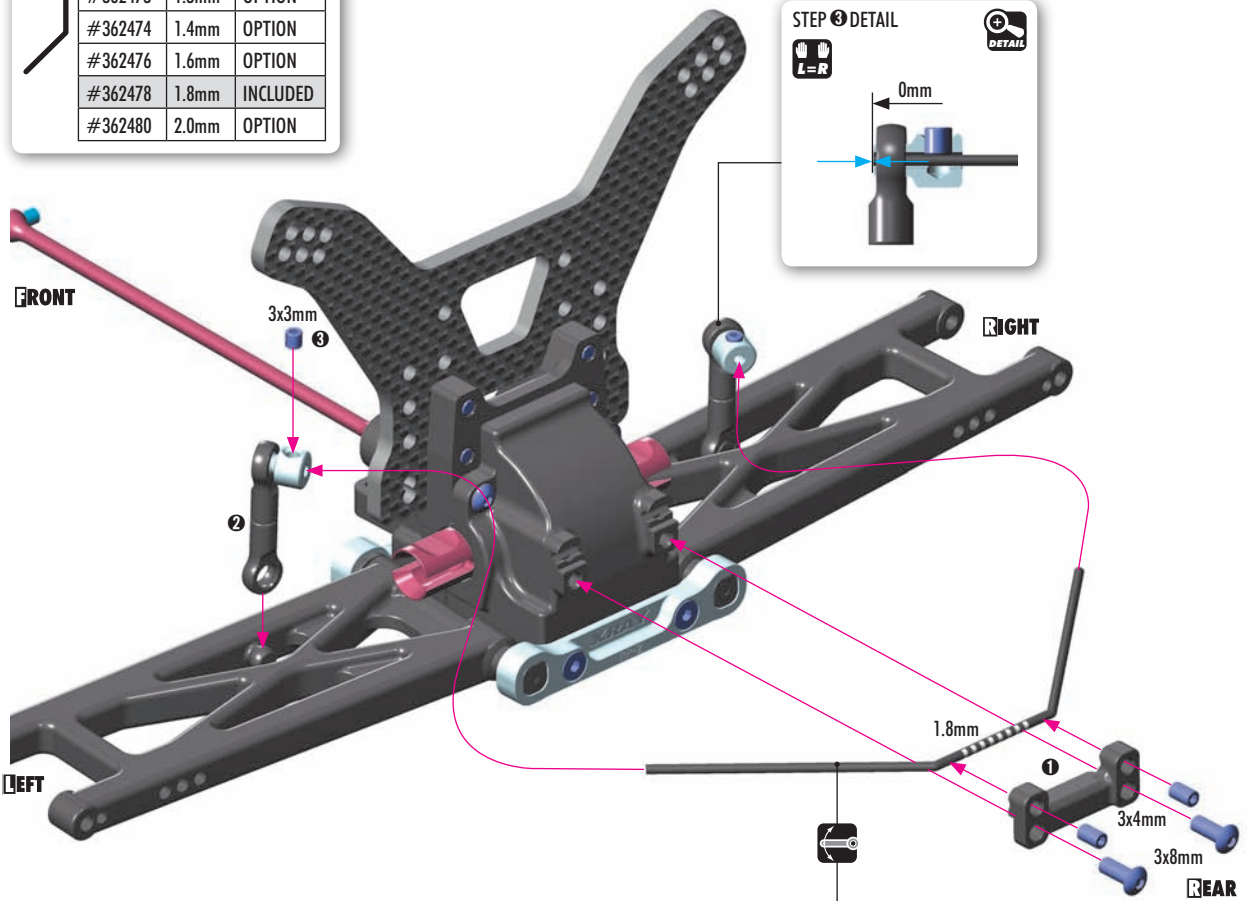

SET-UP BOOK

ANTI-ROLL BAR

3. FRONT SUSPENSION

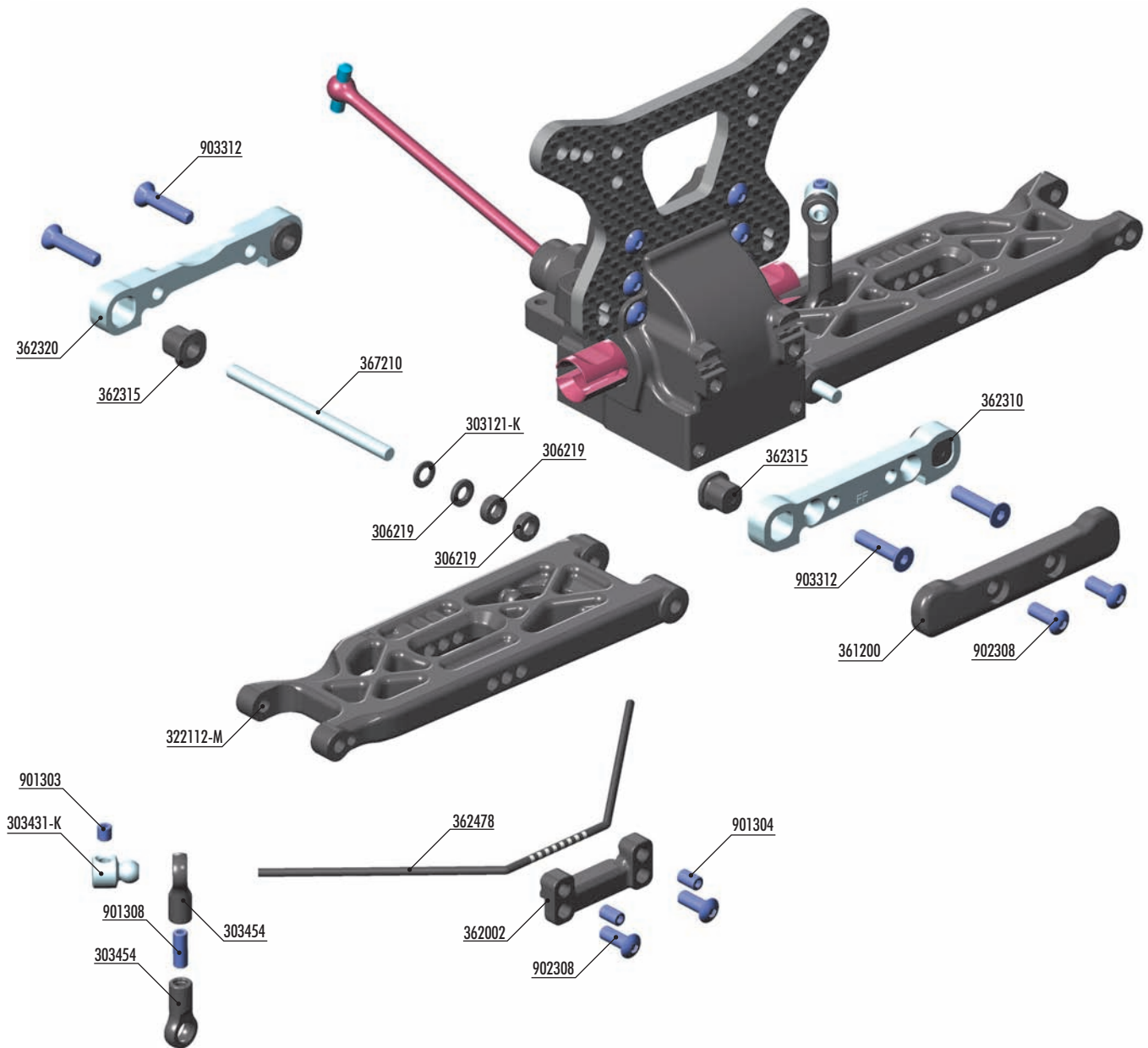

ANTI-ROLL BARS			
OPTION	#362470	1.0mm	OPTION
	#362471	1.1mm	OPTION
	#362472	1.2mm	OPTION
	#362473	1.3mm	OPTION
	#362474	1.4mm	OPTION
	#362476	1.6mm	OPTION
	#362478	1.8mm	INCLUDED
	#362480	2.0mm	OPTION

SUSPENSION ARMS			
OPTION	#322112-M	MEDIUM	INCLUDED
	#322112-G	GRAPHITE	OPTION

BAG

03

- 303121-K ALU SHIM 3x6x0.5MM - BLACK (10)
- 303431-K ALU 4.9MM BALL END - BLACK (2)
- 303454 BALL JOINT 4.9MM - OPEN (4)
- 306219 COMPOSITE SET OF SERVO SHIMS (4)
- 322112-M XT4 COMPOSITE SUSPENSION ARM FRONT LOWER - MEDIUM
- 361200 COMPOSITE BUMPER - V2
- 362002 DIFF BULKHEAD BLOCK SET FRONT - V2
- 362310 ALU FRONT LOWER SUSP. HOLDER - FRONT - 7075 T6 (5MM)
- 362315 ECCENTRIC BUSHING SET (2)

- 362320 ALU FRONT LOWER SUSP. HOLDER - REAR - 7075 T6 (5MM)
- 362478 ANTI-ROLL BAR 1.8 MM
- 367210 SUSPENSION PIVOT PIN (2)
- 901303 HEX SCREW SB M3x3 (10)
- 901304 HEX SCREW SB M3x4 (10)
- 901308 HEX SCREW SB M3x8 (10)
- 902308 HEX SCREW SH M3x8 (10)
- 903312 HEX SCREW SFH M3x12 (10)

3. FRONT SUSPENSION

303121-K
SHIM 3x6x0.5

306219
SHIM 3x6x1

306219
SHIM 3x6x2



903312
SFH M3x12

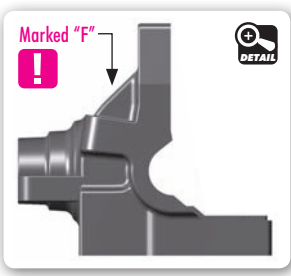

SUSPENSION ARMS			
#322112-M	MEDIUM	INCLUDED	
#322112-G	GRAPHITE	OPTION	

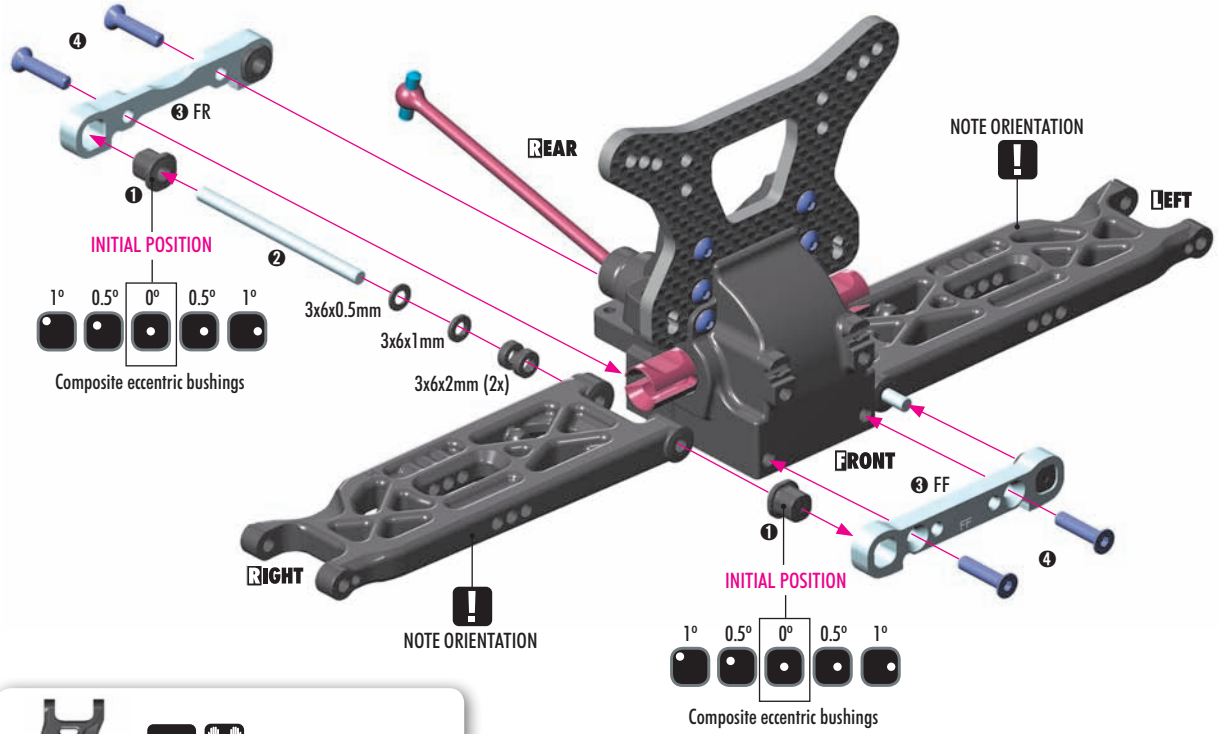

TIP

If the suspension arm does not move freely use a HUDY Arm Reamer to size the holes of the arms

Arm Reamer 3.0mm (HUDY #107633)

SET-UP BOOK
KICK UP
ROLL CENTER
TRACK-WIDTH

ECCENTRIC BUSHINGS HAVE TWO DIFFERENT OFFSETS FROM THE CENTER.

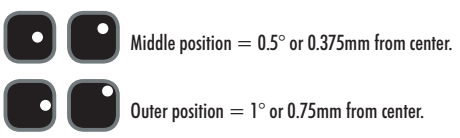

The XRAY alu front lower suspension holders provide great range of adjustment for the front suspension. Using different combinations of eccentric bushings, fine adjustment of front kick-up, roll-center, and front track-width can be obtained. For more information about the influence of kick-up, front track-width, and roll centers on car handling, please refer to HUDY Set-up Book (#209100).

KICK-UP		
FF	FR	(°)
		= 9°
		= 8°
		= 10°
		= 8°
		= 7°
		= 9°
		= 10°
		= 9°
		= 11°

ROLL CENTER		
FF	FR	(mm)
		= +0.75mm
		= 0mm
		= -0.75mm

TRACK-WIDTH		
FF	FR	(mm)
		= +1.5mm
		= 0mm
		= -1.5mm

TOTAL CASTER = C-HUB CASTER + KICK UP					
C-HUB CASTER	KICK-UP				
	7°	8°	9°	10°	11°
6°	13°	14°	15°	16°	17°
9°	16°	17°	18°	19°	20°

The tables describe the amounts of adjustment using the center and outside positions of the eccentric bushings. The middle position eccentric bushings allow for finer adjustment increments.

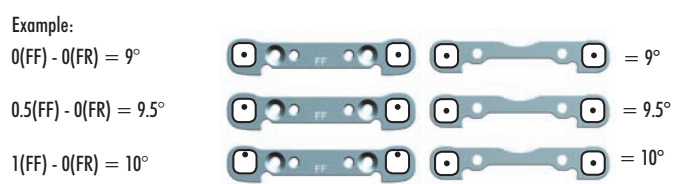

The track-width is directly influenced by the size of the wheels and tires used.

Caster is the angle between the steering pivot axis and the vertical plane. Caster is affected not only by the C-Hub caster, but also by the front kick-up angle relative to the flat chassis bottom. The table indicates how kick up angle effects total caster.

The XT4's stock caster blocks are 9°, but 6° blocks are available as an option.

3. FRONT SUSPENSION



901308
SB M3x8

2x
L=R

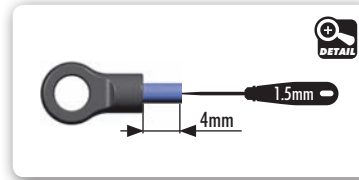
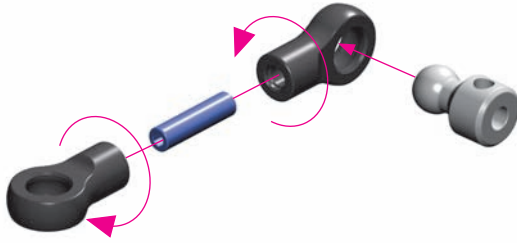

902308
SH M3x8

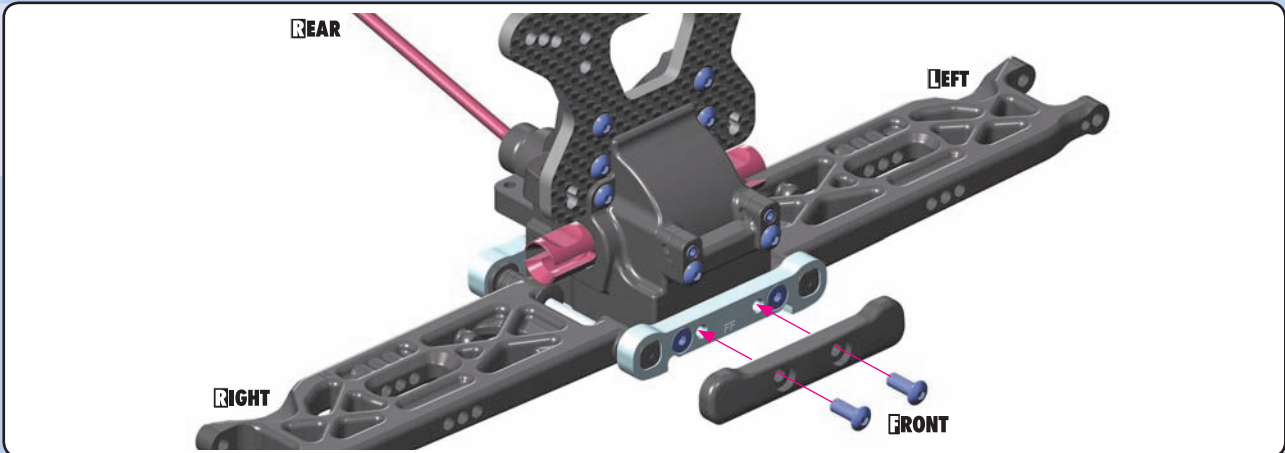

901303
SB M3x3



901304
SB M3x4



902308
SH M3x8

STEP 3 DETAIL

L=R

0mm

ANTI-ROLL BARS		
#362470	1.0mm	OPTION
#362471	1.1mm	OPTION
#362472	1.2mm	OPTION
#362473	1.3mm	OPTION
#362474	1.4mm	OPTION
#362476	1.6mm	OPTION
#362478	1.8mm	INCLUDED
#362480	2.0mm	OPTION

Step 1
Loosen the 3x4 setscrew if the anti-roll bar does not turn freely

Step 1
check for free movement

SET-UP BOOK

ANTI-ROLL BAR

4. REAR TRANSMISSION

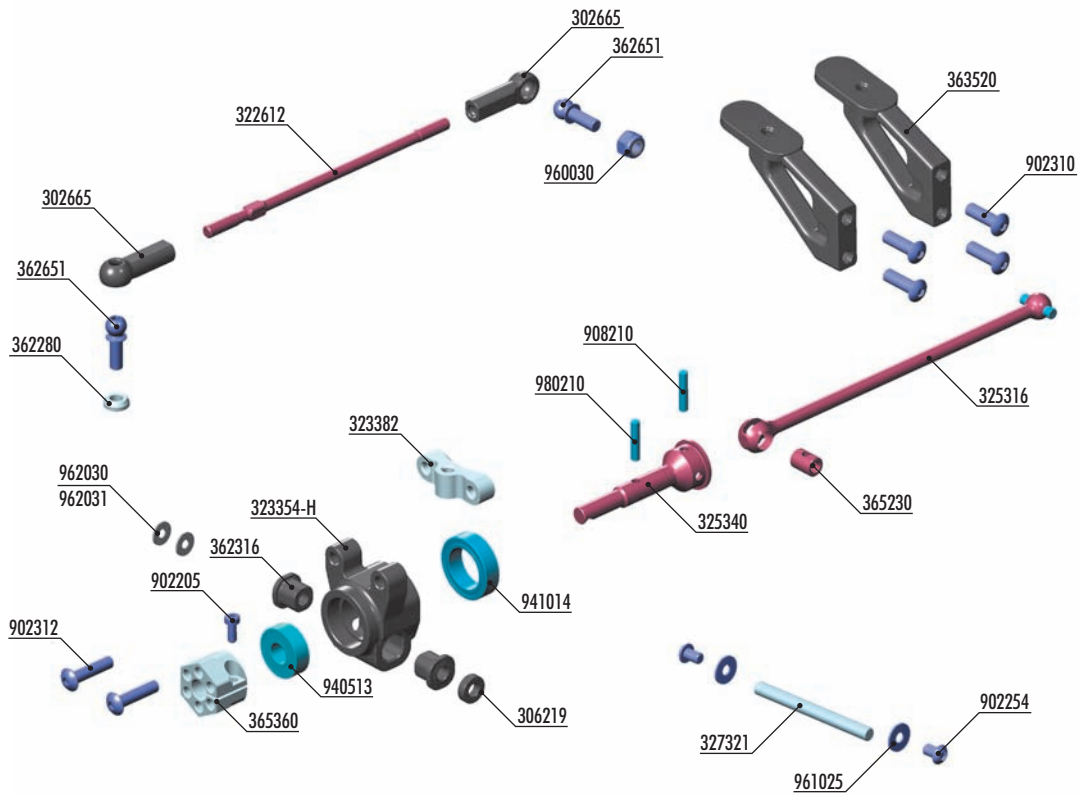

#325341
REAR ADJUSTABLE DRIVE AXLE
LB - HUDY SPRING STEEL™ +
325390 ALU SHIM 10x12x2MM (2)



#323381
ALU REAR HUB PLATE FOR MULTI ADJ.
UPRIGHT - 2-HOLE - SWISS 7075 T6



XRAY BALL-BEARINGS

#	SIZE	LUBRICATION	STATUS
#940512	5x12x4	OIL	OPTION
#941015	10x15x4	OIL	OPTION
#940513	5x12x4	GREASE	INCLUDED
#941014	10x15x4	GREASE	INCLUDED



ALU CONICAL SHIMS

#	COLOR	STATUS
#362280	SILVER	INCLUDED
#362280-K	BLACK	OPTION
#362280-O	ORANGE	OPTION



ALU NUTS M3

#	COLOR	STATUS
#296530-B	ALU BLUE	OPTION
#296530-K	ALU BLACK	OPTION
#296530-O	ALU ORANGE	OPTION
#960030	STEEL SILVER	INCLUDED
#960031	ALU SILVER	OPTION



WHEEL HUBS 12MM

#	OFFSET	SLOTS	STATUS
#365360	+4.5mm	- 6 slots	INCLUDED
#365359	+3.75mm	- 5 slots	OPTION
#365358	+3.0mm	- 4 slots	OPTION
#365357	+2.25mm	- 3 slots	OPTION
#365356	+1.5mm	- 2 slots	OPTION
#365355	+0.75mm	- 1 slot	OPTION
#365353	0mm	- 0 slots	OPTION
#365354	-0.75mm	- Lightw.	OPTION

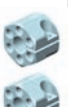

WHEEL HUBS 14MM

#	OFFSET	STATUS
#365352	+0.75mm	OPTION
#365350	0mm	OPTION
#365351	-0.75mm	OPTION



BAG

04

- 30 2665 COMPOSITE BALL JOINT 4.9MM - CLOSED WITH HOLE (4)
- 30 6219 CCOMPOSITE SET OF SERVO SHIMS (4)
- 32 2612 ADJ. TURNBUCKLE 75MM M3 L/R - HUDY SPRING STEEL™ (2)
- 32 3354-H COMPOSITE UPRIGHT REAR - HARD
- 32 3382 ALU REAR HUB PLATE FOR MULTI ADJ. UPRIGHT - 1-HOLE
- 32 5316 XT4 REAR DRIVE SHAFT 92MM WITH 2.5MM PIN - SPRING STEEL™
- 32 5340 REAR DRIVE AXLE LB - HUDY SPRING STEEL™
- 32 7321 REAR ARM PIVOT PIN 3x34MM(2)
- 36 2280 ALU CONICAL SHIM 3x6x2.0MM (10)
- 36 2316 OPEN ECCENTRIC BUSHING SET (2)
- 36 2651 BALL END 4.9MM WITH THREAD 8MM (2)
- 36 3520 REAR WING POST - V2 (2)
- 36 5230 DRIVE SHAFT COUPLING - HUDY SPRING STEEL™
- 36 5360 ALU WHEEL HUB 12MM - OFFSET "+4.5MM" (2)

- 90 2205 HEX SCREW SH M2x5 (10)
- 90 2254 HEX SCREW SH M2.5x4 (10)
- 90 2310 HEX SCREW SH M3x10 (10)
- 90 2312 HEX SCREW SH M3x12 (10)
- 94 0513 BALL-BEARING 5x12x4 RUBBER SEALED - GREASE (2)
- 94 1014 BALL-BEARING 10x15x4 RUBBER SEALED - GREASE (2)
- 96 0030 NUT M3 (10)
- 96 1025 WASHER S 2.5 (10)
- 96 2030 WASHER S 3x6x0.3 (10)
- 96 2031 WASHER S 3x6x0.1 (10)
- 98 0210 PIN 2x10 (10)

4. REAR TRANSMISSION

980210
P 2x10

2x **L=R**

DRIVE SHAFT (92mm) **!**

LONG AXLE

#106210 HUDY GRAPHITE GREASE
#106213 HUDY JOINT GREASE - OPTION

OPTION #325341
REAR ADJUSTABLE DRIVE AXLE LB - HUDY SPRING STEEL™ + 325390 ALU SHIM 10x12x2MM (2)

940513
BB 5x12x4

941014
BB 10x15x4

980210
P 2x10

902205
SH M2x5

2x **L=R**

Use HUDY Ball-Bearing Grease
#106220 - STANDARD
#106221 - BLUE
#106222 - RED

10x15x4mm

5x12x4mm

Bearing with BLACK rubber covers

OPTION **WHEEL HUBS 12MM**

#365360	+4.5mm - 6 slots	INCLUDED
#365359	+3.75mm - 5 slots	OPTION
#365358	+3.0mm - 4 slots	OPTION
#365357	+2.25mm - 3 slots	OPTION
#365356	+1.5mm - 2 slots	OPTION
#365355	+0.75mm - 1 slot	OPTION
#365353	0mm - 0 slots	OPTION
#365354	-0.75mm - Lightw.	OPTION

OPTIONAL HEX HUB EFFECTS

Different offset hex hubs are used to increase or decrease the track-width.

LESS OFFSET
Rear - more traction
Front - more steering

MORE OFFSET
Rear - less traction
Front - less steering

OPTION **REAR UPRIGHTS**

#323354-H	HARD	INCLUDED
#323354-G	GRAPHITE	OPTION
#323355	ALU	OPTION

902312
SH M3x12

2x **L=R**

! NOTE ORIENTATION
INITIAL SETTING

ALTERNATIVE ORIENTATION

OPTION #323381
ALU REAR HUB PLATE FOR MULTI ADJ. UPRIGHT - 2-HOLE - SWISS 7075 T6

4. REAR TRANSMISSION

IO

306219
SHIM 3x6x2



902254
SH M2.5x4



961025
S 2.5



962030 S 3x6x0.3 962031 S 3x6x0.1

SET-UP BOOK

WHEELBASE

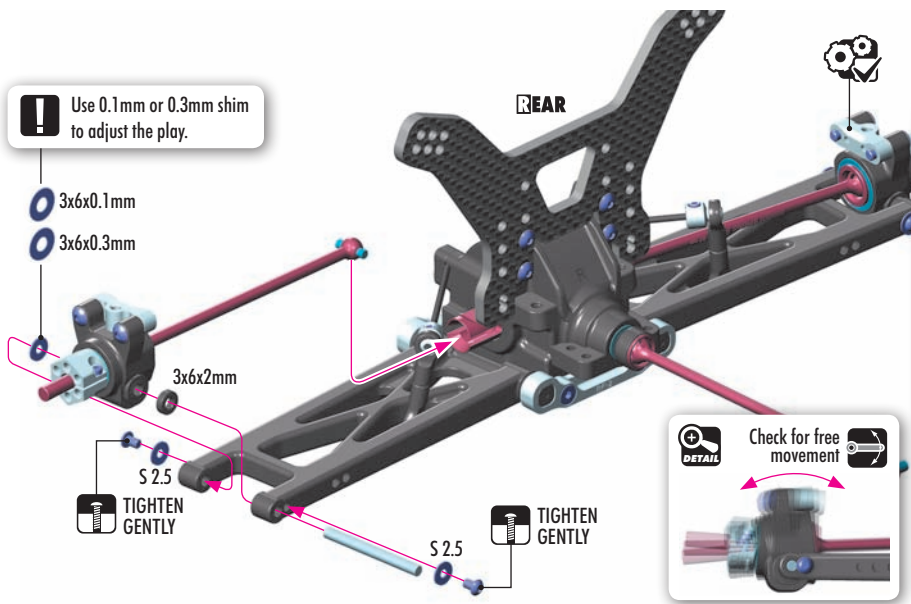

! Use 0.1mm or 0.3mm shim to adjust the play.

3x6x0.1mm
3x6x0.3mm

TIGHTEN GENTLY

TIGHTEN GENTLY



LONGER WHEELBASE (INITIAL SETTING)

Adjustment Shim IN FRONT OF HUB moves hub rearward.

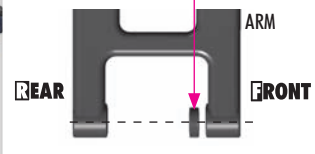

SHORTER WHEELBASE

Adjustment Shim BEHIND HUB moves hub forward.

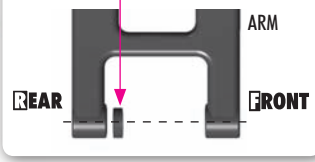

SET-UP BOOK

CAMBER

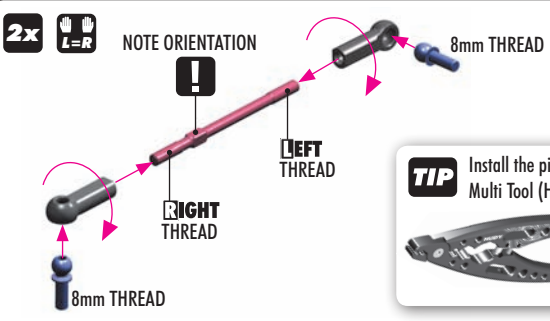

2x L=R

NOTE ORIENTATION

8mm THREAD

LEFT THREAD

RIGHT THREAD

TIP Install the pivot balls with Professional Multi Tool (HUDY #183011)



59mm

2x L=R

SET-UP BOOK

ROLL CENTER



362280
CON. SHIM 3x6x2



960030
N M3

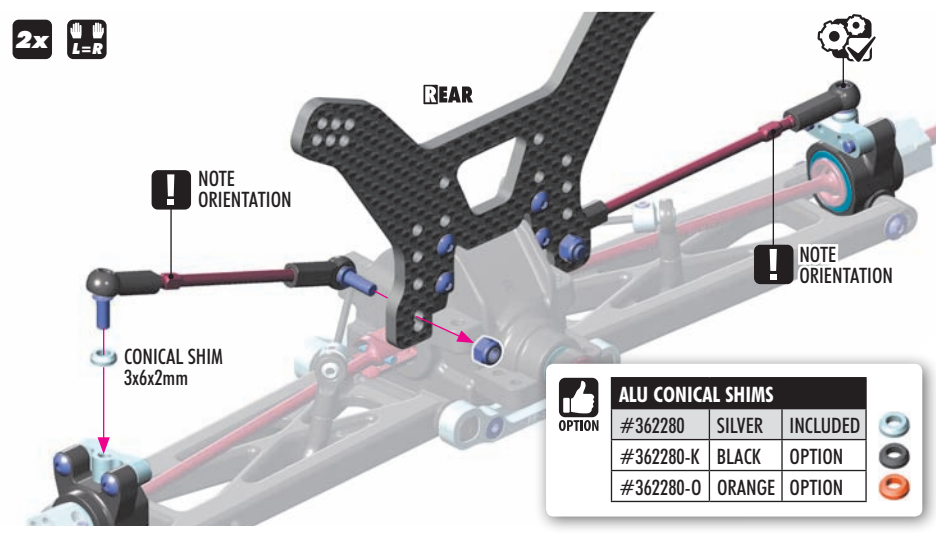

2x L=R

! NOTE ORIENTATION

! NOTE ORIENTATION

CONICAL SHIM
3x6x2mm

OPTION	ALU CONICAL SHIMS	
#362280	SILVER	INCLUDED
#362280-K	BLACK	OPTION
#362280-O	ORANGE	OPTION

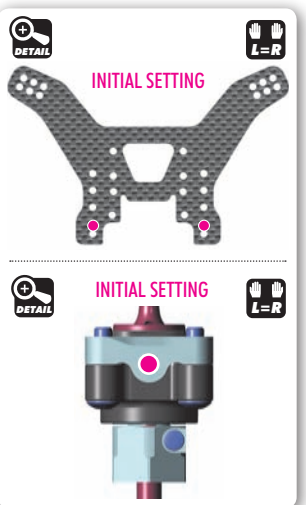

INITIAL SETTING

INITIAL SETTING

4. FRONT TRANSMISSION

WHEEL HUBS 12MM		
OPTION	#365360	+4.5mm OPTION
	#365359	+3.75mm OPTION
	#365358	+3.00mm OPTION
	#365357	+2.25mm OPTION
	#365356	+1.5mm OPTION
	#365355	+0.75mm OPTION
	#365353	0mm INCLUDED
	#365354	-0.75mm OPTION

WHEEL HUBS 14MM		
OPTION	#365352	+0.75mm OPTION
	#365350	0mm OPTION
	#365351	-0.75mm OPTION

C-HUBS		
OPTION	#362210	RIGHT 9° - M OPTION
	#362210-H	RIGHT 9° - H INCLUDED
	#362210-G	RIGHT 9° - G OPTION
	#362211	RIGHT 6° OPTION
	#362234	ALU RIGHT 12° OPTION
	#362220	LEFT 9° - M OPTION
	#362220-H	LEFT 9° - H INCLUDED
	#362220-G	LEFT 9° - G OPTION
	#362221	LEFT 6° OPTION
	#362244	ALU LEFT 12° OPTION

ALU NUTS M3		
OPTION	#296530-B	ALU BLUE OPTION
	#296530-K	ALU BLACK OPTION
	#296530-O	ALU ORANGE OPTION
	#960030	STEEL SILVER INCLUDED
	#960031	ALU SILVER OPTION

ALU CONICAL SHIMS		
OPTION	#362280	SILVER INCLUDED
	#362280-K	BLACK OPTION
	#362280-O	ORANGE OPTION

STEERING BLOCKS		
OPTION	#362250	MEDIUM OPTION
	#362250-H	HARD INCLUDED
	#362250-G	GRAPHITE OPTION

XRAY BALL-BEARINGS			
OPTION	#940510	5x10x4 OIL	OPTION
	#940512	5x12x4 OIL	OPTION
	#359050	5x10x4 GREASE	INCLUDED
	#940513	5x12x4 GREASE	INCLUDED

DRIVE SHAFT COLLARS		
OPTION	#365470	COMPOSITE INCLUDED
	#365471-K	ALU - BLACK OPTION
	#365471-O	ALU - ORANGE OPTION

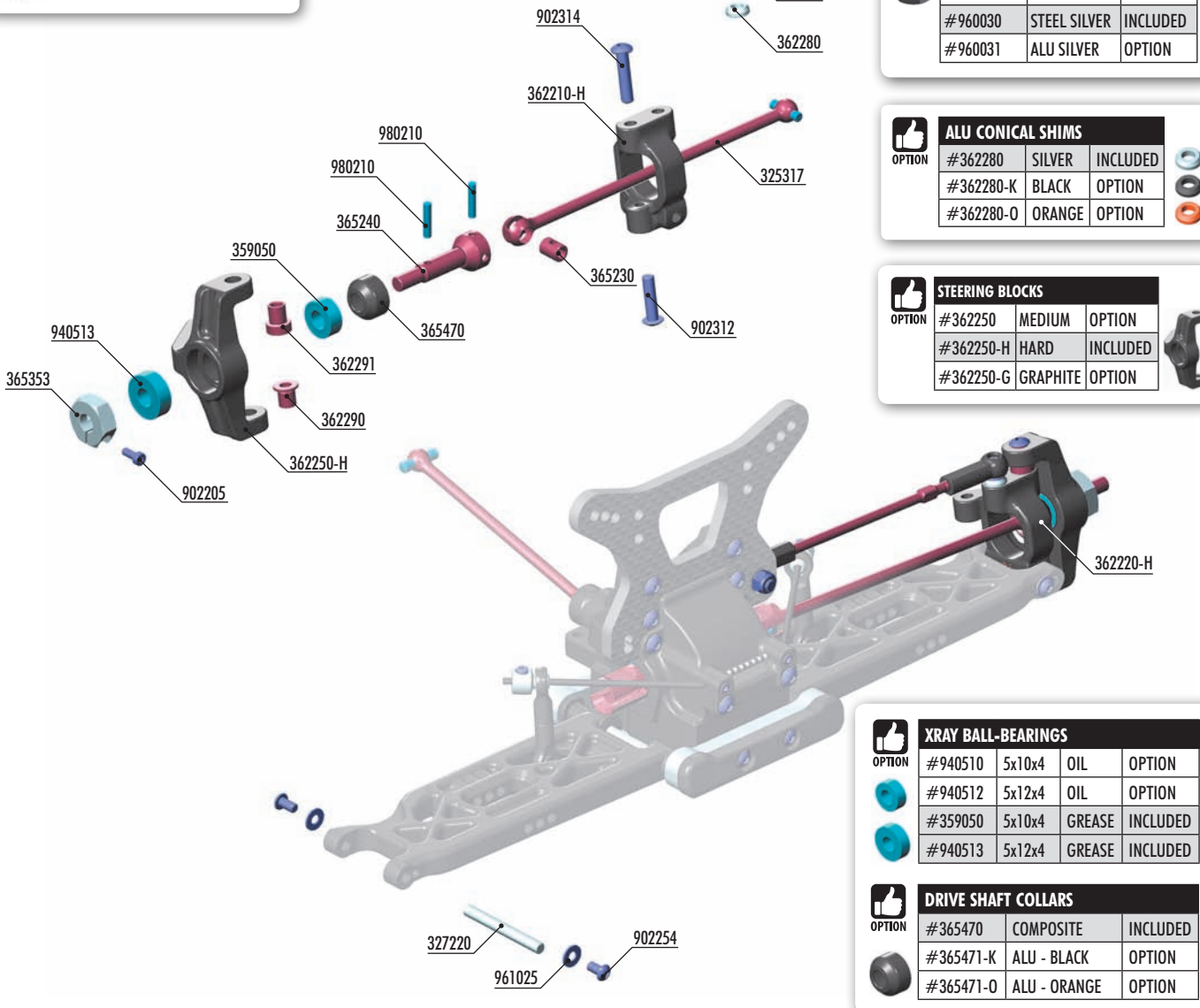

BAG
04

302665	COMPOSITE BALL JOINT 4.9MM - CLOSED WITH HOLE (4)	365240	FRONT DRIVE AXLE - HUDY SPRING STEEL™
322611	ADJ. TURNBUCKLE M3 L/R 70 MM - SPRING STEEL (2)	365353	ALU WHEEL HUB 12MM (2)
325317	XT4 FRONT DRIVE SHAFT 99MM WITH 2.5MM PIN - HUDY SPRING STEEL™	365470	COMPOSITE DRIVE SHAFT SAFETY COLLAR (3)
327220	FRONT ARM PIVOT PIN (2)	359050	BALL-BEARING 5x10x4 STEEL SEALED - GREASE (2)
362210-H	COMPOSITE C-HUB 9° DEG. RIGHT - HARD	902205	HEX SCREW SH M2x5 (10)
362220-H	COMPOSITE C-HUB 9° DEG. LEFT - HARD	902254	HEX SCREW SH M2.5x4 (10)
362250-H	COMPOSITE STEERING BLOCK - HARD	902312	HEX SCREW SH M3x12 (10)
362280	ALU CONICAL SHIM 3x6x2.0MM (10)	902314	HEX SCREW SH M3x14 (10)
362290	STEEL STEERING BUSHING - SHORT (2)	940513	BALL-BEARING 5x12x4 RUBBER SEALED - GREASE (2)
362291	STEEL STEERING BUSHING - LONG (2)	960030	NUT M3 (10)
362651	BALL END 4.9MM WITH THREAD 8MM (2)	961025	WASHER S 2.5 (10)
362652	BALL END 4.9MM WITH THREAD 10MM (2)	980210	PIN 2x10 (10)
365230	DRIVE SHAFT COUPLING - HUDY SPRING STEEL™		

4. FRONT TRANSMISSION

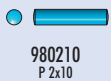

2x L=R

DRIVE SHAFT (99mm) !

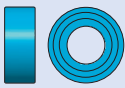
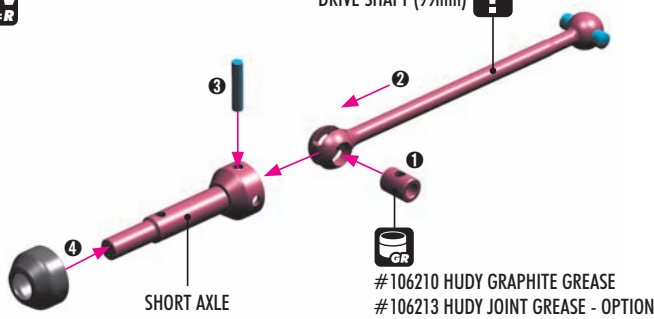

359050
BB 5x10x4

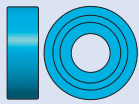

940513
BB 5x12x4

Use HUDY Ball-Bearing Grease

#106220 - STANDARD
#106221 - BLUE
#106222 - RED



XRAY BALL-BEARINGS				
OPTION	#940510	5x10x4	OIL	OPTION
	#940512	5x12x4	OIL	OPTION
	#359050	5x10x4	GREASE	INCLUDED
	#940513	5x12x4	GREASE	INCLUDED

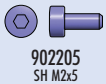

902205
SH M2x5



980210
P 2x10

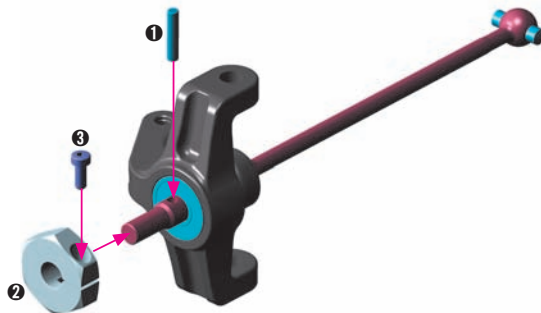

OPTION

WHEEL HUBS 12MM

#365360	+4.5mm	OPTION
#365359	+3.75mm	OPTION
#365358	+3.00mm	OPTION
#365357	+2.25mm	OPTION
#365356	+1.5mm	OPTION
#365355	+0.75mm	OPTION
#365353	0mm	INCLUDED
#365354	-0.75mm	OPTION

OPTIONAL HEX HUB EFFECTS

Different off-set hex hubs are used to increase or decrease the track-width.

LESS OFF-SET

Rear - more traction
Front - more steering

MORE OFF-SET

Rear - less traction
Front - less steering



902312
SH M3x12



902314
SH M3x14

2x L=R

! IMPORTANT

Be sure to use the shorter screw with shorter bushing and longer screw with longer bushing.

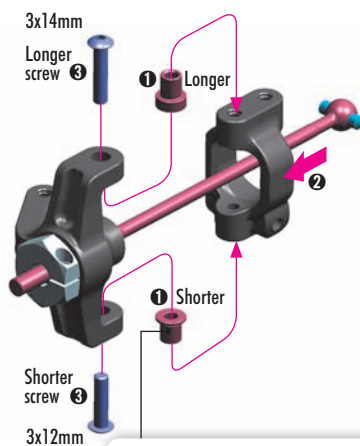

Steel steering bushings allow roll-center adjustment.

! IMPORTANT

When inserting the bushings, make sure that bushings are inserted equally on both right and left hub to give the same roll center position.

DETAIL

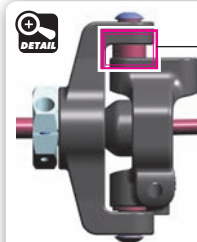

INITIAL POSITION

LOWER ROLL CENTER

TOP = LONGER bushing & 3x14 screw
BOTTOM = SHORTER bushing & 3x12 screw

Recommended for rough tracks to improve stability.

DETAIL

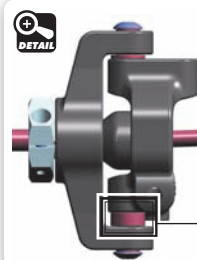

HIGHER ROLL CENTER

TOP = SHORTER bushing & 3x12 screw
BOTTOM = LONGER bushing & 3x14 screw

Recommended for smooth tracks to gain more steering.

SET-UP BOOK
CASTER
ROLL CENTER

4. FRONT TRANSMISSION



902254
SH M2.5x4



961025
S 2.5

2x

L=R

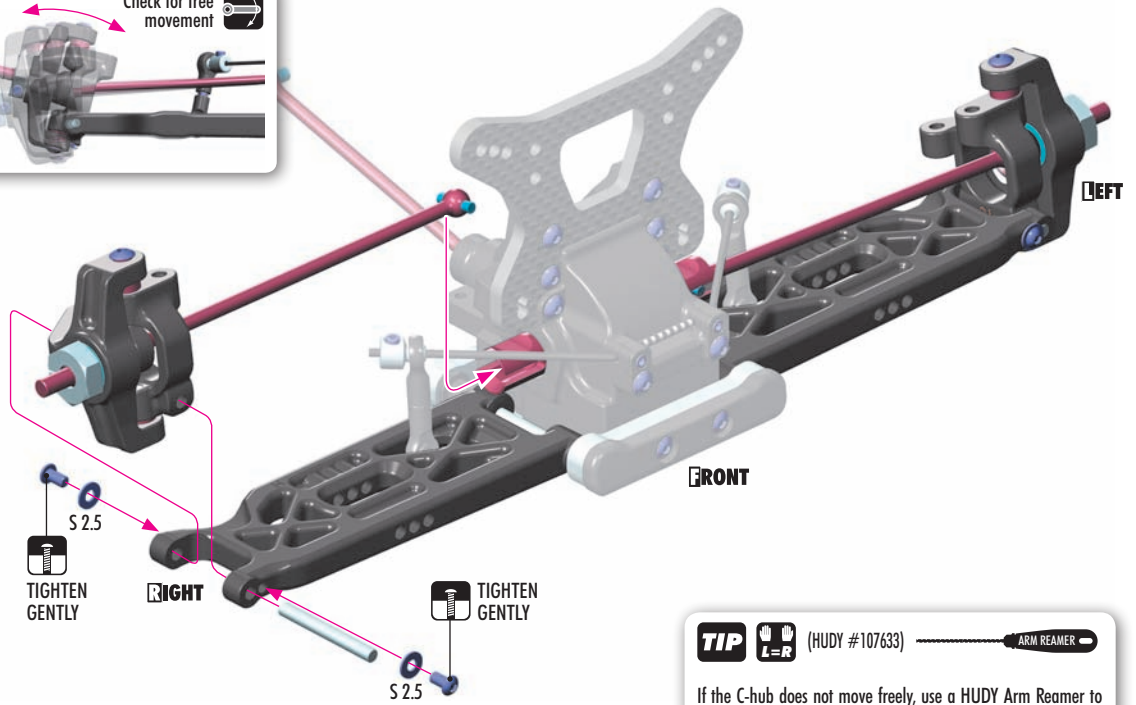

TIP (HUDY #107633) ARM REAMER

If the C-hub does not move freely, use a HUDY Arm Reamer to resize the hole.

2x

L=R



SET-UP BOOK

CAMBER



362280
CON. SHIM 3x6x2



960030
N M3

2x

L=R

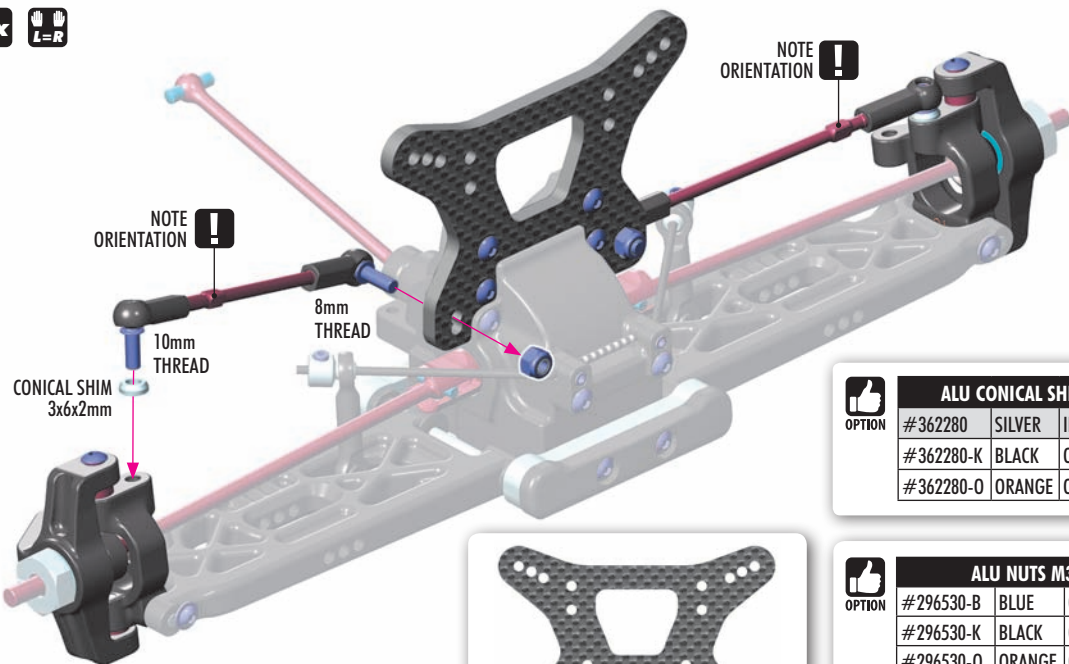

ALU CONICAL SHIMS			
OPTION	#362280	SILVER	INCLUDED
	#362280-K	BLACK	OPTION
	#362280-O	ORANGE	OPTION

ALU NUTS M3			
OPTION	#296530-B	BLUE	OPTION
	#296530-K	BLACK	OPTION
	#296530-O	ORANGE	OPTION
	#960030	STEEL	INCLUDED
	#960031	SILVER	OPTION

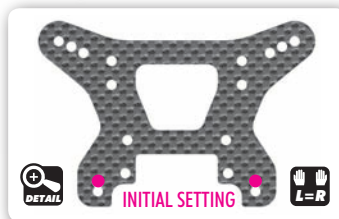

SET-UP BOOK

ROLL CENTER

4. FRONT & REAR ASSEMBLY

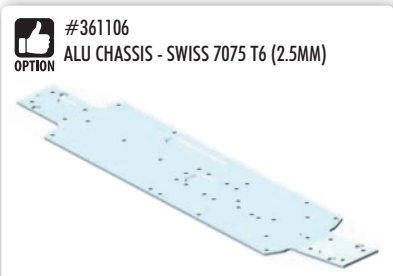
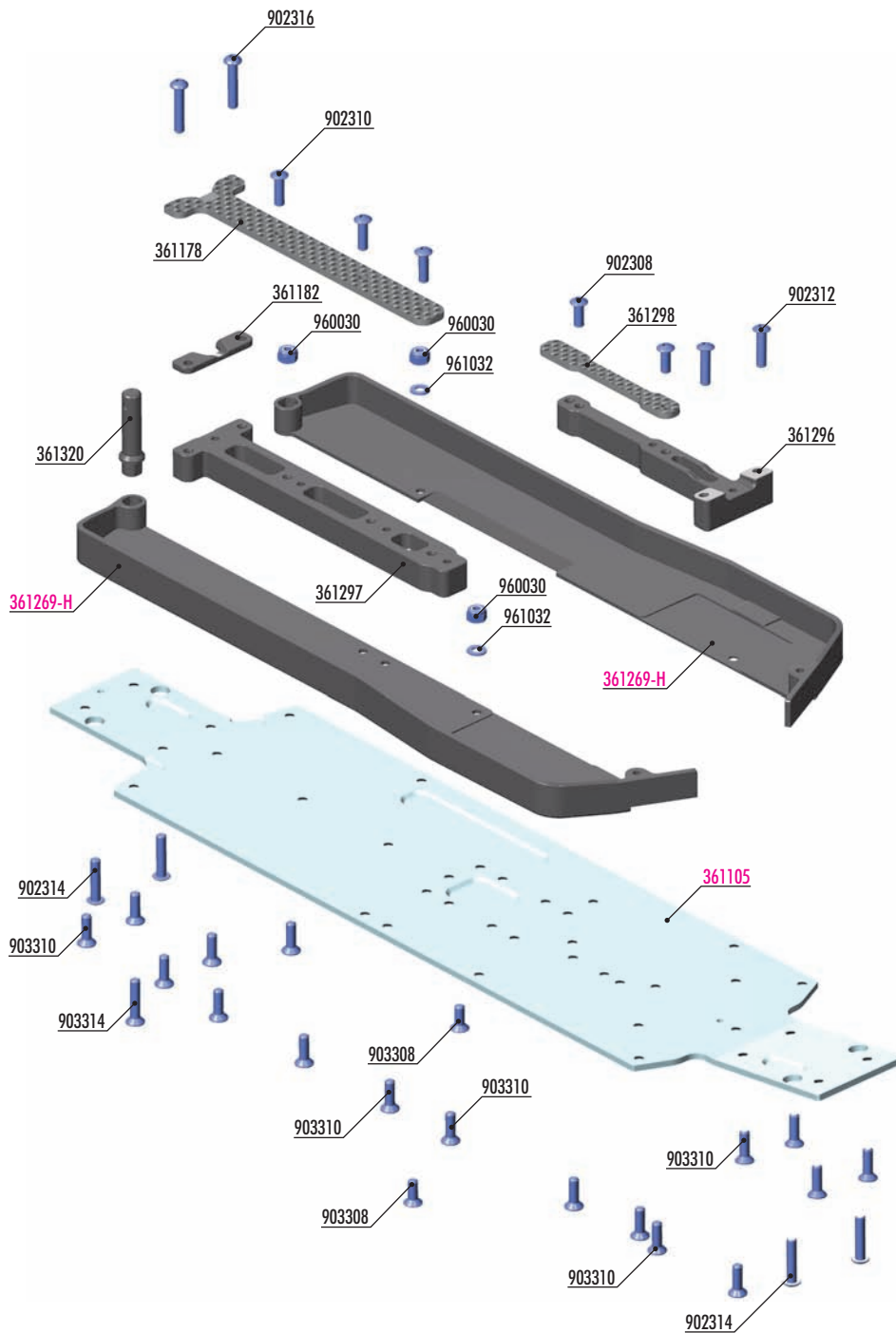

ALU NUTS M3		
#296530-B	ALU BLUE	OPTION
#296530-K	ALU BLACK	OPTION
#296530-O	ALU ORANGE	OPTION
#960030	STEEL SILVER	INCLUDED
#960031	ALU SILVER	OPTION



- 361178 GRAPHITE CHASSIS BRACE UPPER DECK 2.0MM
- 361182 COMPOSITE REAR LOWER BRACE
- 361296 COMPOSITE CHASSIS BRACE FRONT - HARD
- 361297 COMPOSITE CHASSIS BRACE REAR - HARD
- 361298 GRAPHITE CHASSIS WIRE COVER 2.0MM - V2
- 361320 BODY MOUNT, BATTERY MOUNT - V2 & WING SHIM (2)
- 902308 HEX SCREW SH M3x8 (10)
- 902310 HEX SCREW SH M3x10 (10)
- 902312 HEX SCREW SH M3x12 (10)

- 902314 HEX SCREW SH M3x14 (10)
- 902316 HEX SCREW SH M3x16 (10)
- 903308 HEX SCREW SFH M3x8 (10)
- 903310 HEX SCREW SFH M3x10 (10)
- 903314 HEX SCREW SFH M3x14 (10)
- 960030 NUT M3 (10)
- 961032 WASHER S 3.2 (10)
- 361105 ALU CHASSIS - SWISS 7075 T6 (2MM)
- 361269-H COMPOSITE CHASSIS SIDE GUARDS L+R - HARD

4. FRONT & REAR ASSEMBLY



903308
SFH M3x8

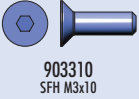

903310
SFH M3x10



903314
SFH M3x14



960030
N M3



961032
S 3.2

SET-UP BOOK

CHASSIS FLEX

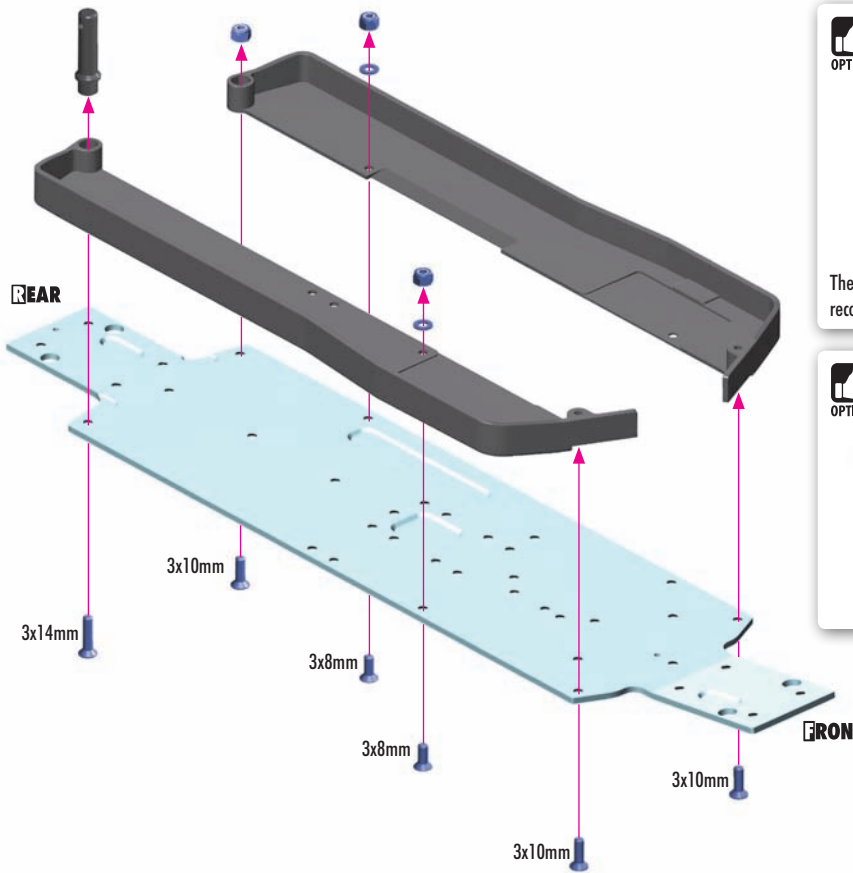

#361269-M
OPTION COMPOSITE CHASSIS SIDE GUARDS L+R (MEDIUM)



The medium side guards increase chassis flex and are recommended for low-traction tracks.

#361106
OPTION ALU CHASSIS - SWISS 7075 T6 (2.5MM)



ALU NUTS M3		
#296530-B	ALU BLUE	OPTION
#296530-K	ALU BLACK	OPTION
#296530-O	ALU ORANGE	OPTION
#960030	STEEL SILVER	INCLUDED
#960031	ALU SILVER	OPTION



902308
SH M3x8



902310
SH M3x10



903310
SFH M3x10

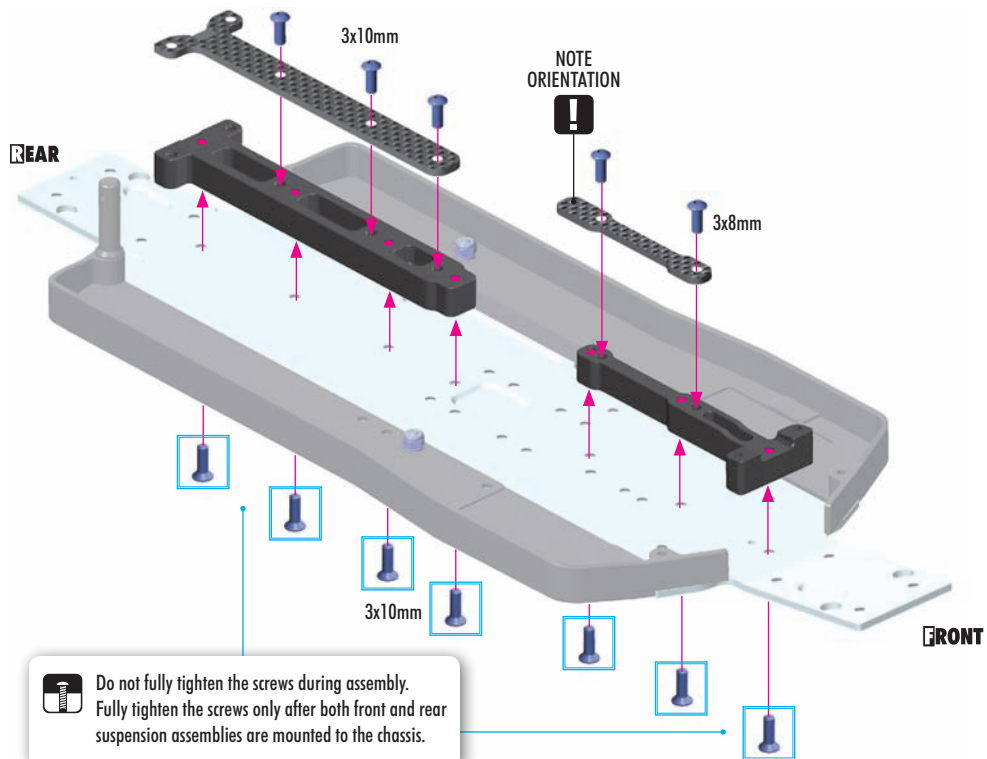

Do not fully tighten the screws during assembly.
Fully tighten the screws only after both front and rear suspension assemblies are mounted to the chassis.

#361179
OPTION BRASS CHASSIS BRACE REAR (40g)



#361295
OPTION COMPOSITE CHASSIS BRACE REAR - MEDIUM



#361294
OPTION COMPOSITE CHASSIS BRACE FRONT - MEDIUM



4. FRONT & REAR ASSEMBLY



902314
SH M3x14



902316
SH M3x16



903310
SFH M3x10

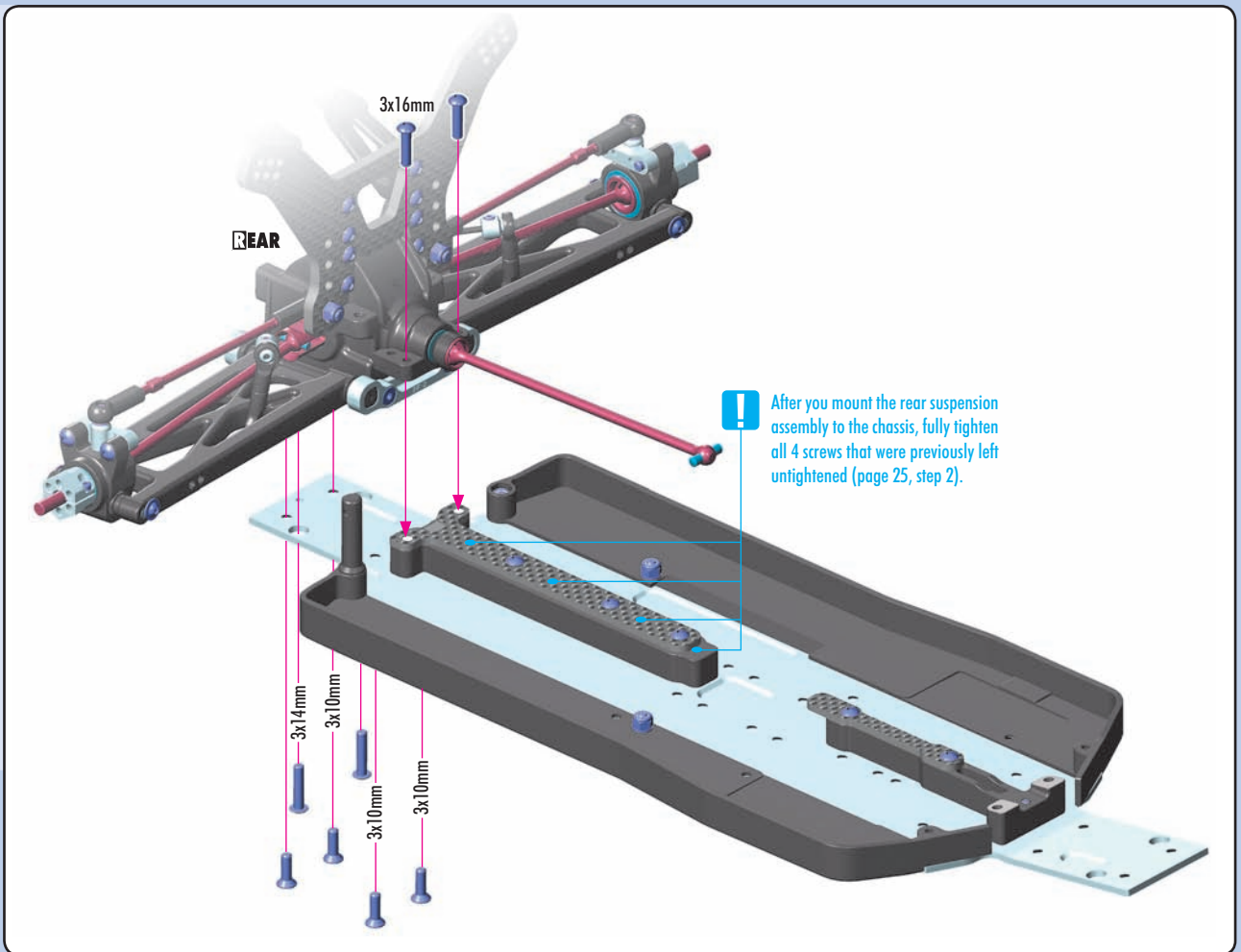

902312
SH M3x12



902314
SH M3x14



903310
SFH M3x10

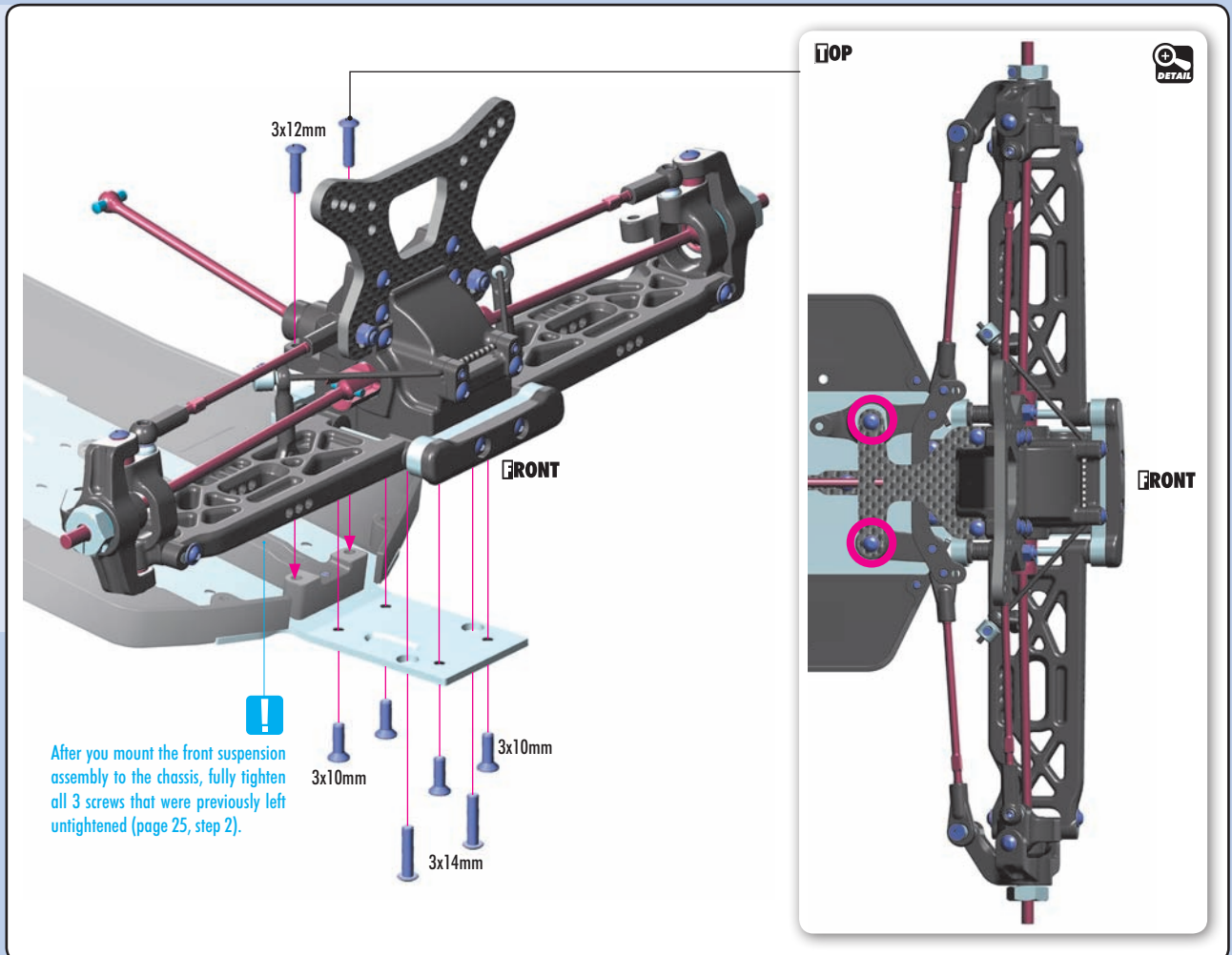

5. STEERING

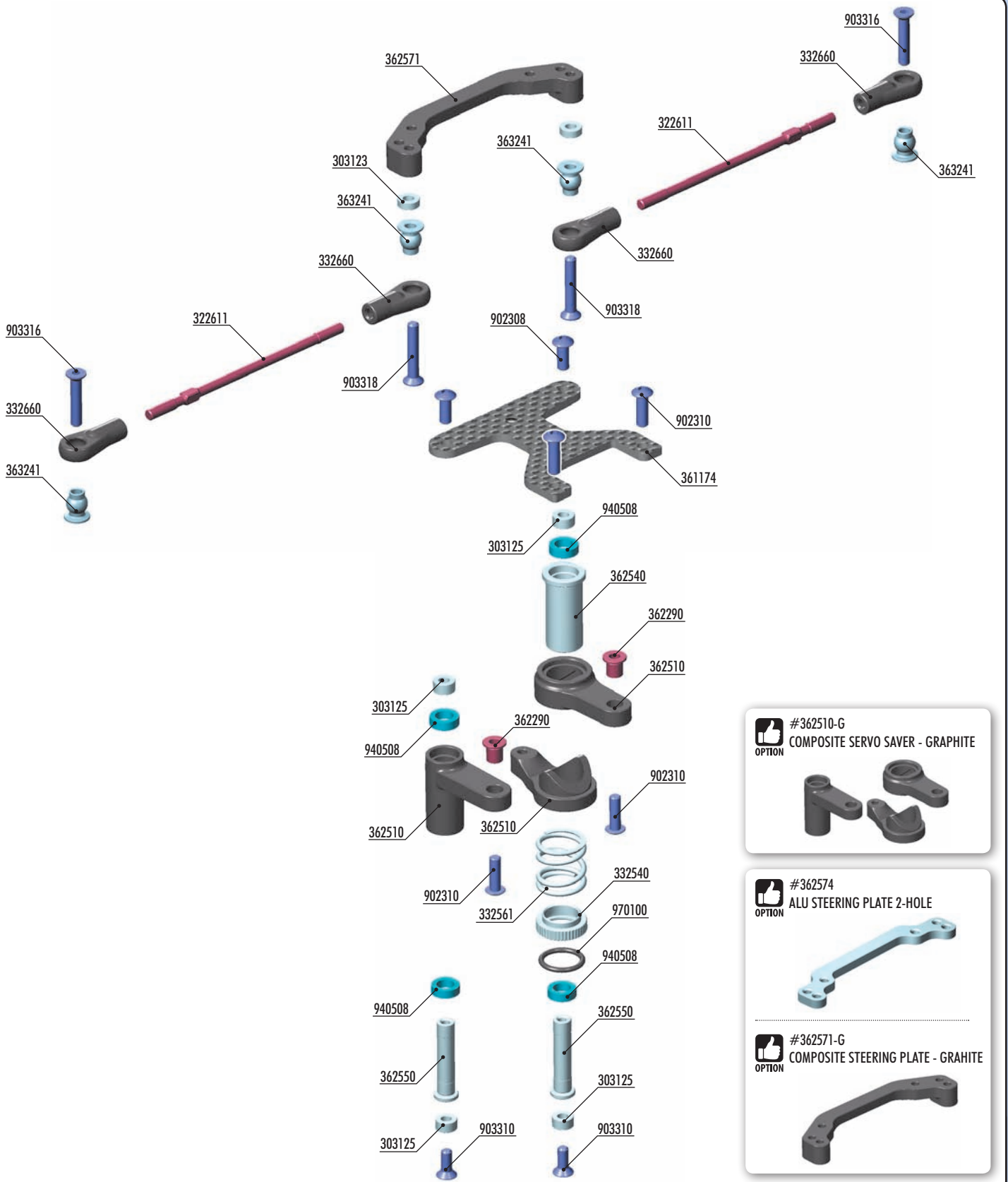

BAG

05

- 303123 ALU SHIM 3x6x2.0MM (10)
- 303125 ALU SHIM 3x6x3.0MM (10)
- 322611 ADJ. TURNBUCKLE M3 L/R 70MM - SPRING STEEL™ (2)
- 332540 ALU SERVO SAVER ADJUSTABLE NUT
- 332561 SERVO SAVER SPRING C=14
- 332660 COMPOSITE STEERING & SERVO BALL JOINT 5.8 MM (4+2)
- 361174 GRAPHITE FRONT UPPER STEERING DECK 2.0MM
- 362290 STEEL STEERING BUSHING - SHORT (2)
- 362510 COMPOSITE SERVO SAVER
- 362540 ALU SERVO SAVER MAIN SHAFT
- 362550 SERVO SAVER PIVOT SHAFT (2)

- 362571 COMPOSITE STEERING PLATE
- 363241 BALL UNIVERSAL 5.75MM WITH BACKSTOP (2)
- 902308 HEX SCREW SH M3x8 (10)
- 902310 HEX SCREW SH M3x10 (10)
- 903310 HEX SCREW SFH M3x10 (10)
- 903316 HEX SCREW SFH M3x16 (10)
- 903318 HEX SCREW SFH M3x18 (10)
- 940508 BALL-BEARING 5x8x2.5 RUBBER SEALED - OIL (2)
- 970100 O-RING 10 x 1.5 (10)

5. STEERING



970100
O 10x1.5

SET-UP BOOK

SERVO SAVER

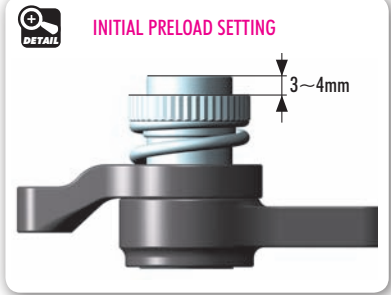
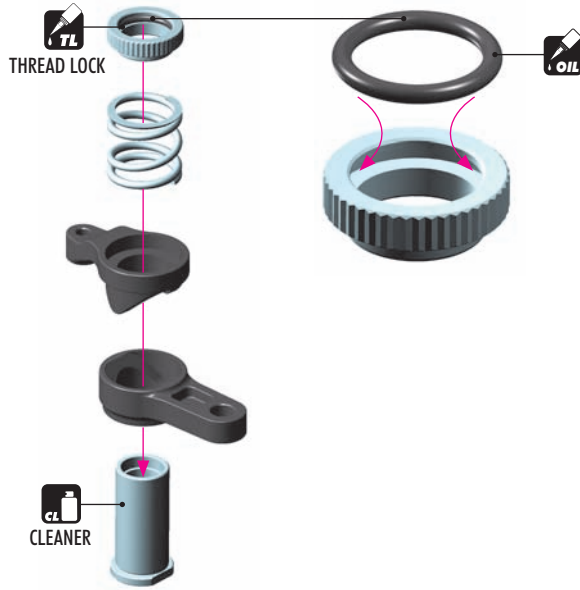

902310
SH M3x10

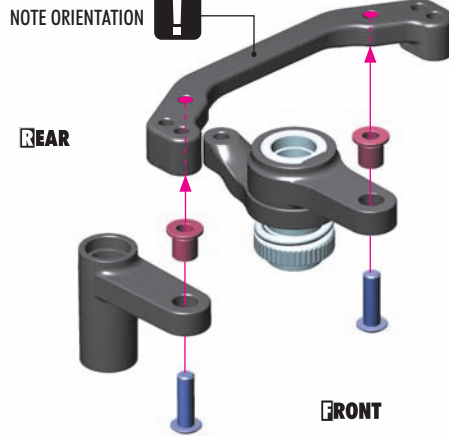

OPTION

STEERING PLATES

OPTION	STEERING PLATES		
#362571	HARD	INCLUDED	
#362571-G	GRAPHITE	OPTION	
#362574	ALU	OPTION	



Increases steering precision and predictability and is recommended for use in high-traction conditions. Includes extra Ackermann positions for very precise steering adjustment.



902308
SH M3x8



303125
SHIM 3x6x3



940508
BB 5x8x2.5

NOTE ORIENTATION

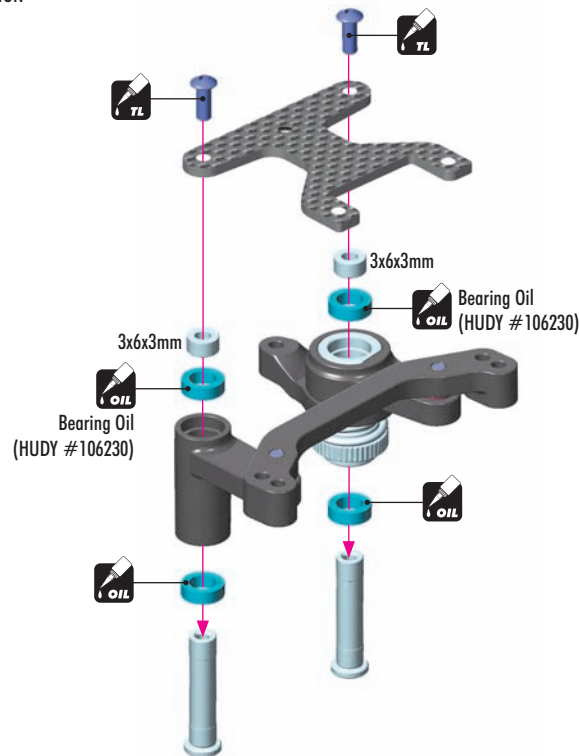

5. STEERING



303125
SHIM 3x6x3



902310
SH M3x10



903310
SFH M3x10

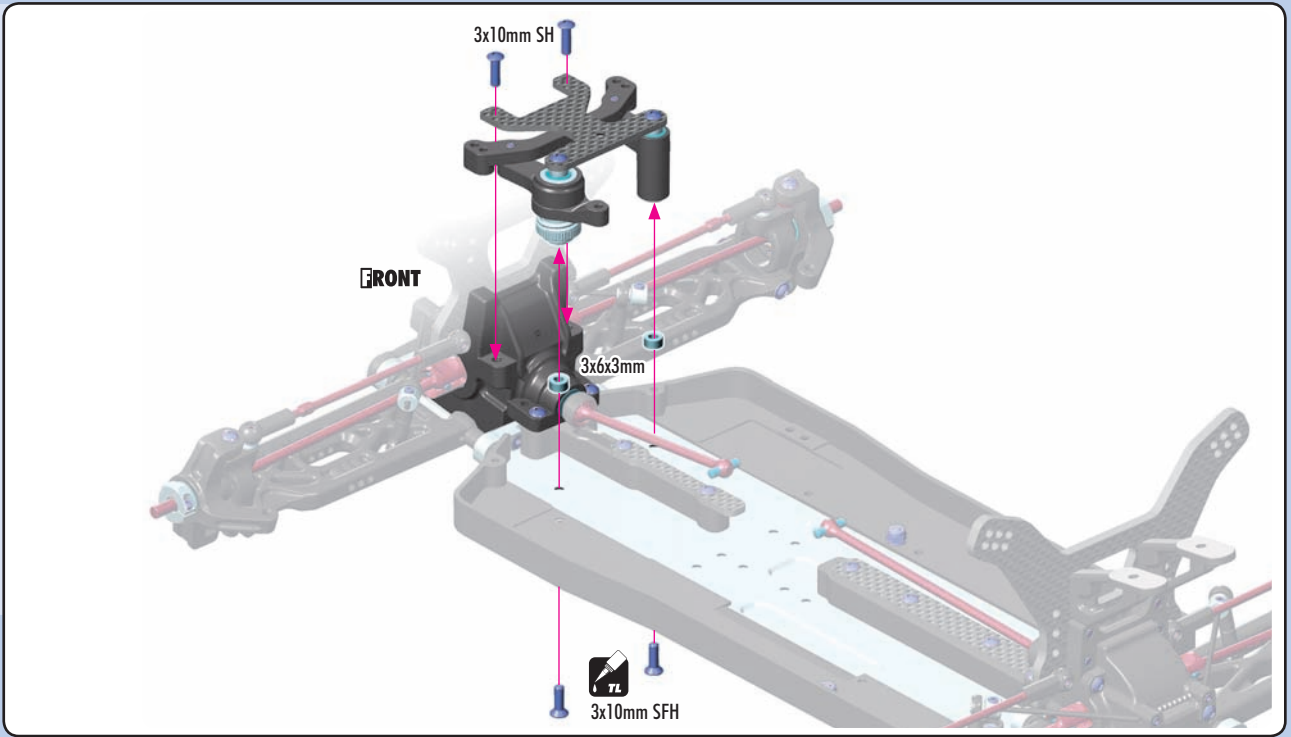

2x L=R

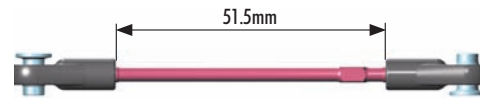
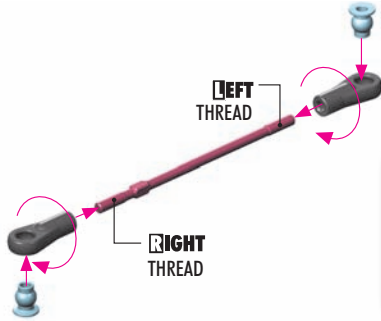

TIP Install the pivot balls with Professional Multi Tool (HUDY #183011)



303125
SHIM 3x6x2



903316
SFH M3x16



903318
SFH M3x18

2x L=R

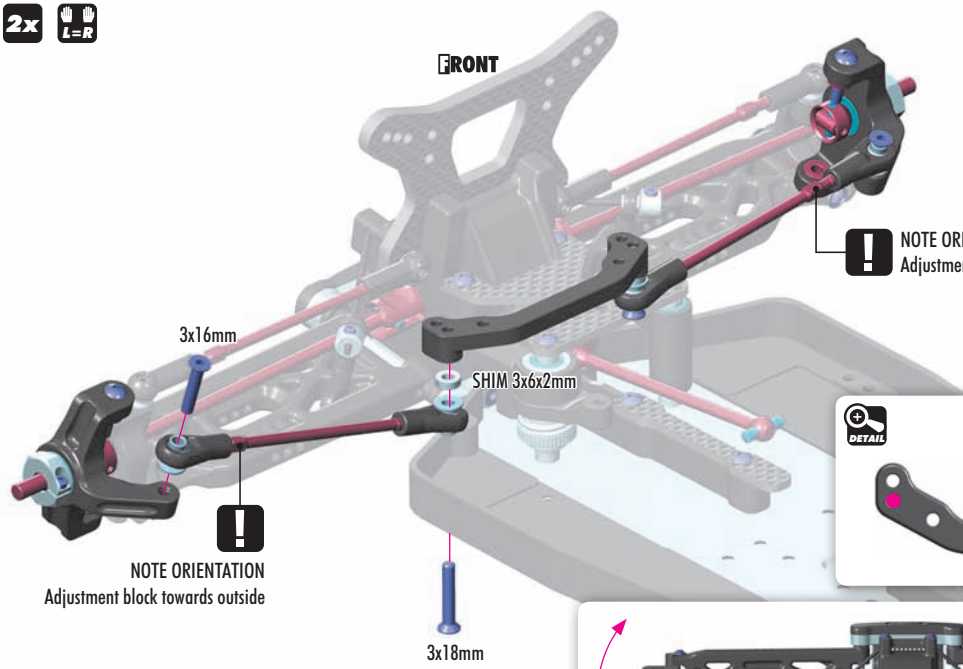

! NOTE ORIENTATION
Adjustment block towards outside

! NOTE ORIENTATION
Adjustment block towards outside



TOP view

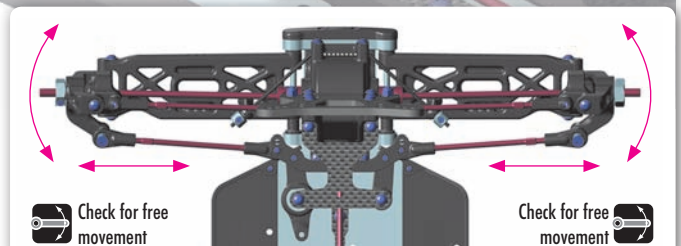

SET-UP BOOK

ACKERMANN
BUMP STEER
TOE-IN

6. SLIPPER CLUTCH ASSEMBLY

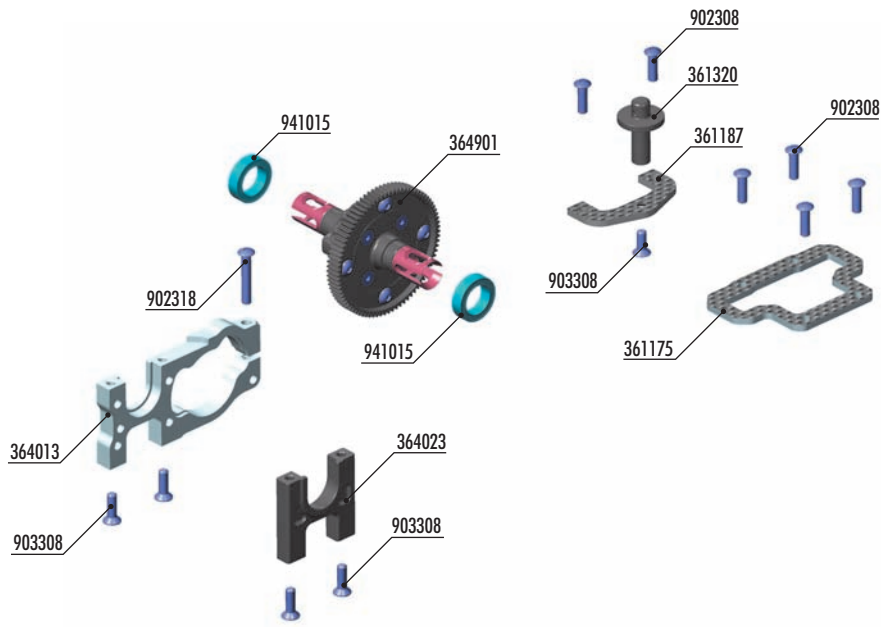

BAG

06

- 361175 GRAPHITE CENTER UPPER DECK 2.0MM - V2
- 361187 GRAPHITE REAR UPPER BRACE 2.0MM
- 361320 BODY MOUNT, BATTERY MOUNT - V2 & WING SHIM (2)
- 364013 ALU MOTOR BULKHEAD - LOWER
- 364023 COMPOSITE CENTRAL BULKHEAD - LOWER

- 902308 HEX SCREW SH M3x8 (10)
- 902318 HEX SCREW SH M3x18 (10)
- 903308 HEX SCREW SFH M3x8 (10)
- 941015 BALL-BEARING 10x15x4 RUBBER SEALED - OIL (2)

- 364901 GEAR CENTER DIFFERENTIAL - SET

ALTERNATIVE 1

FORWARD WEIGHT POSITION
(INITIAL SETTING)

REAR

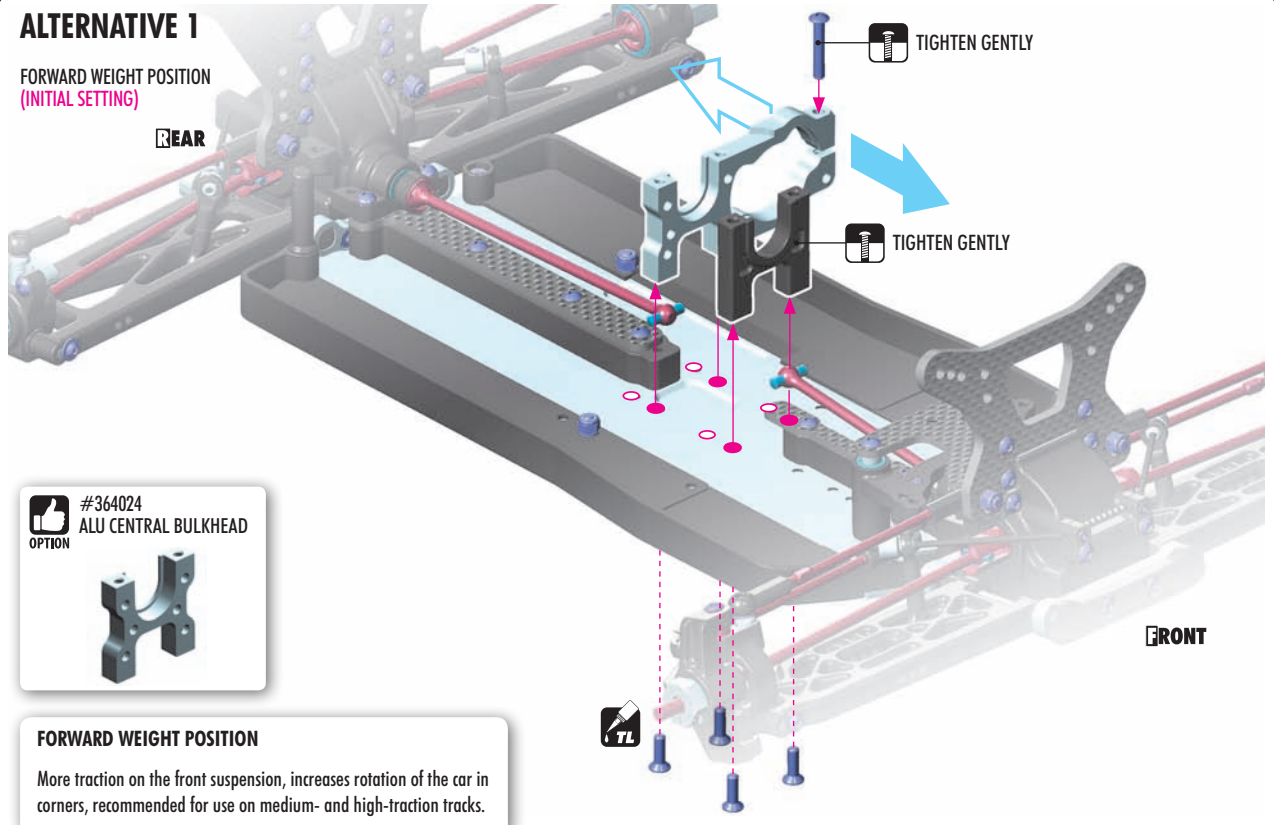

FORWARD WEIGHT POSITION
More traction on the front suspension, increases rotation of the car in corners, recommended for use on medium- and high-traction tracks.

6. SLIPPER CLUTCH ASSEMBLY

ALTERNATIVE 2

REARWARD WEIGHT POSITION (OPTION)



902318
5H M3x18



903308
SFH M3x8

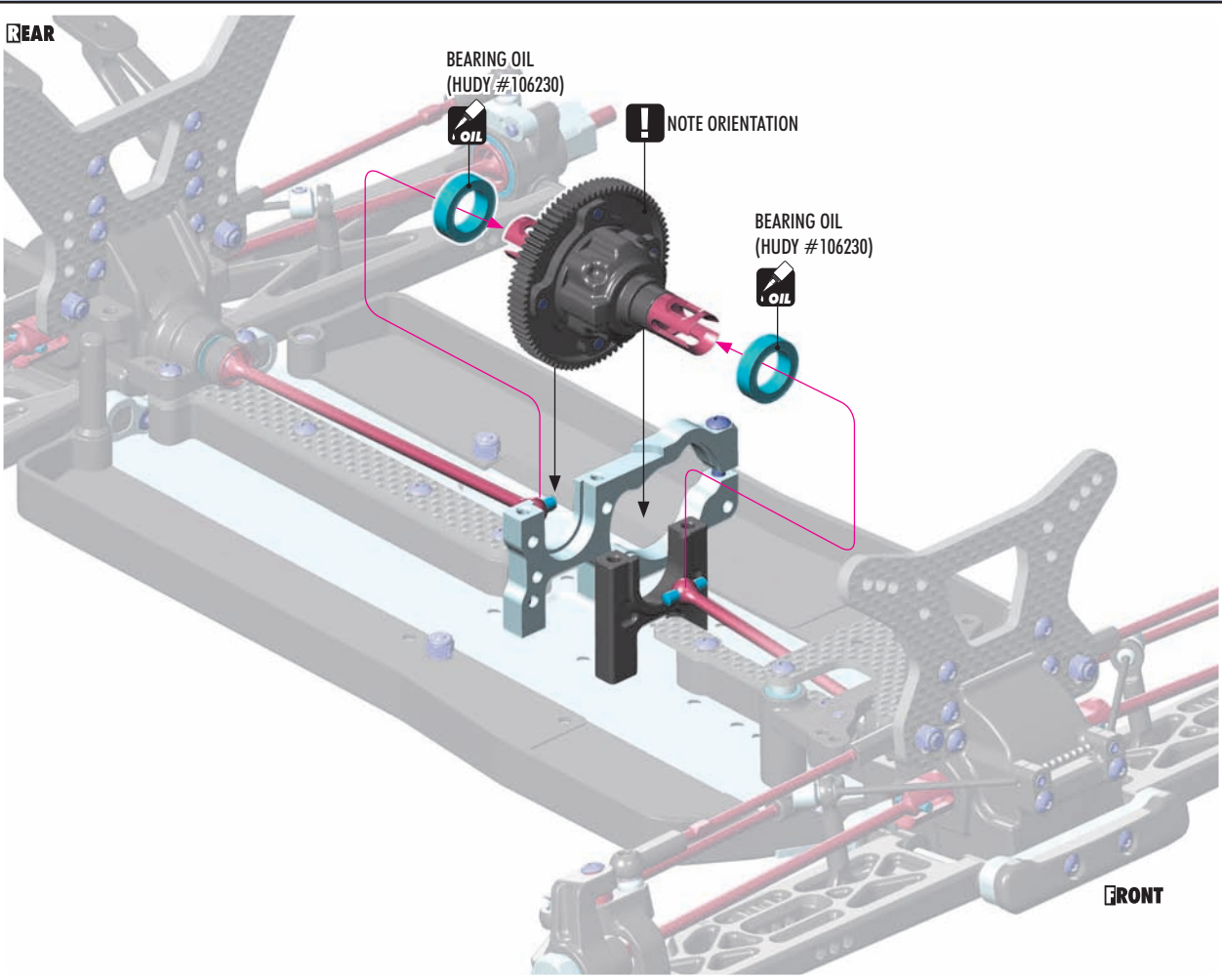
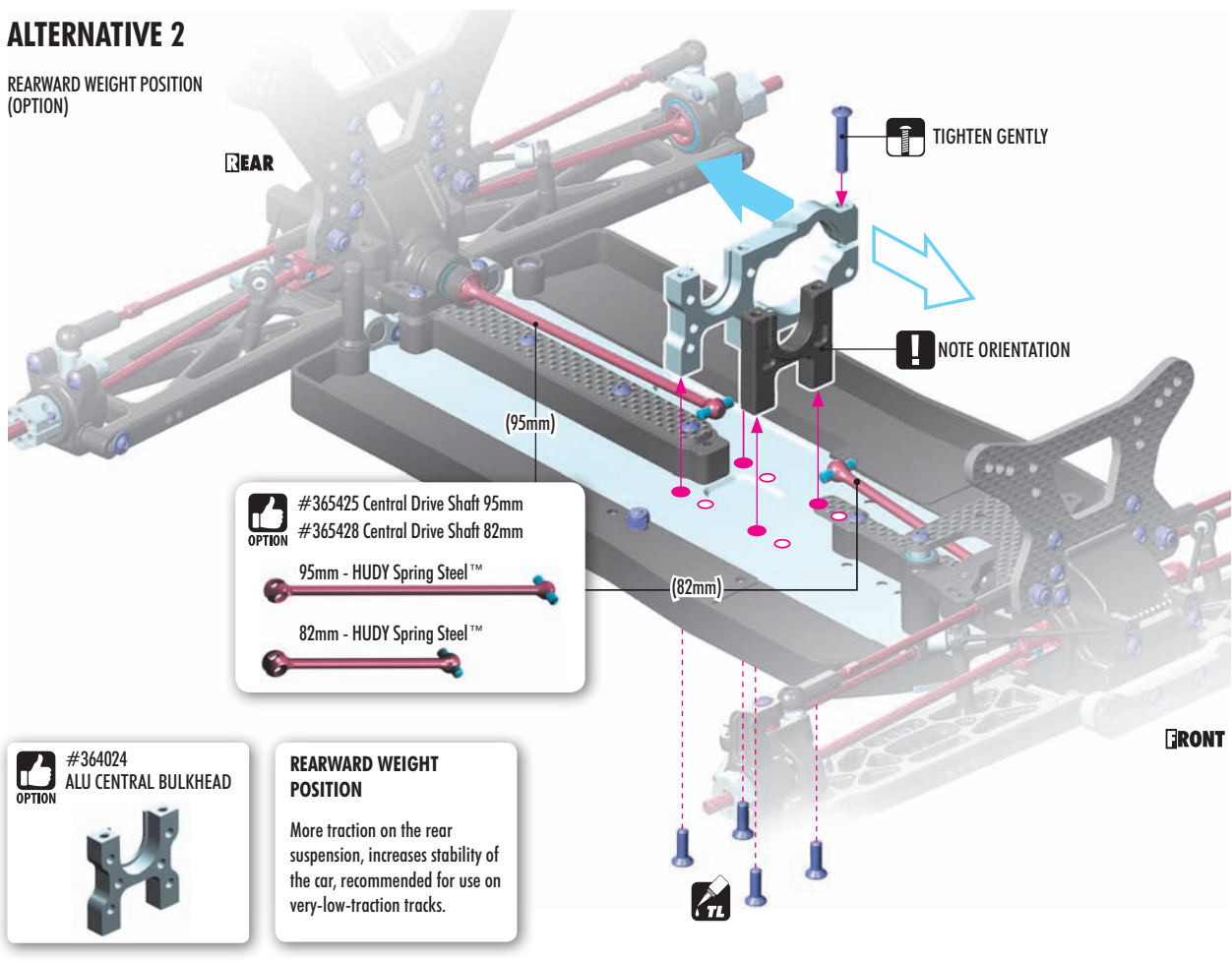

941015
BB 10x15x4

6. SLIPPER CLUTCH ASSEMBLY

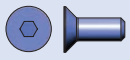

903308
SFH M3x8

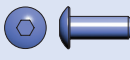
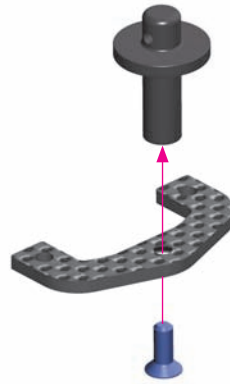

902308
SH M3x8

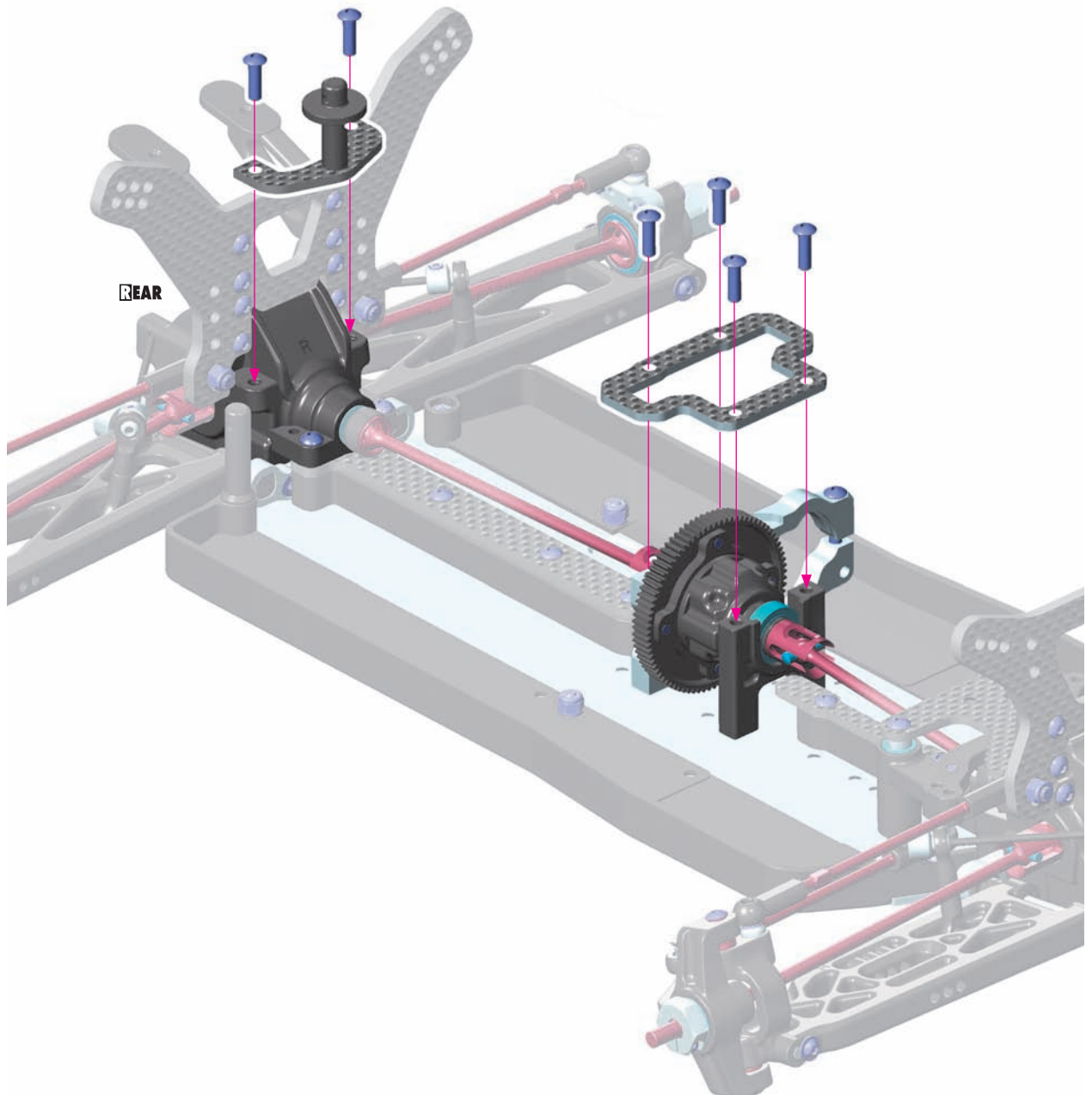

7. SHOCK ABSORBERS

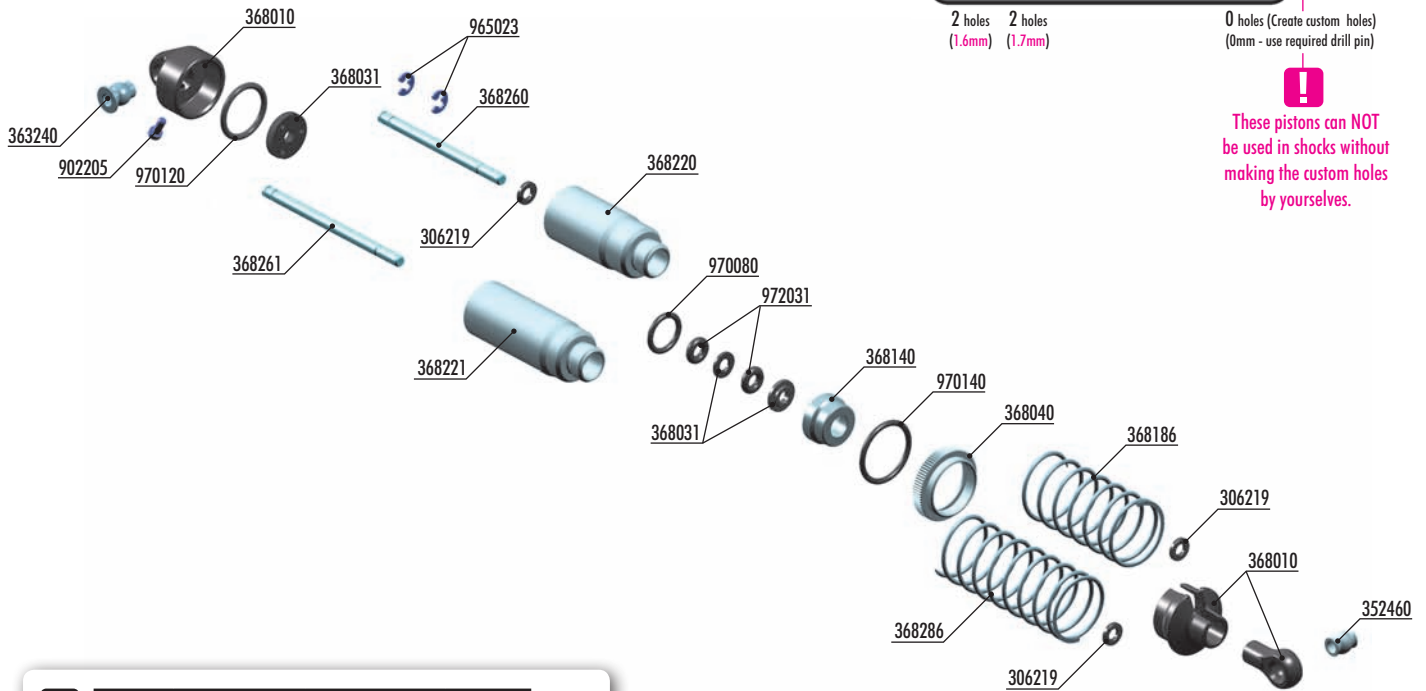

FRONT SPRINGS

#368174	PROGRESS.	2 STRIPES	OPTION
#368175	PROGRESS. 40mm	3 DOTS	OPTION
#368182	LINEAR 45mm	1 STRIPE & 3 DOTS	OPTION
#368183	LINEAR	1 DOT	OPTION
#368184	LINEAR	2 DOTS	OPTION
#368185	LINEAR	3 DOTS	OPTION
#368186	LINEAR	4 DOTS	INCLUDED



REAR SPRINGS

#368273	PROGRESS.	2 STRIPES	OPTION
#368275	PROGRESS. 55mm	2 DOTS	OPTION
#368283	LINEAR	1 STRIPE & 3 DOTS	OPTION
#368284	LINEAR	1 DOT	OPTION
#368285	LINEAR	2 DOTS	OPTION
#368286	LINEAR	3 DOTS	INCLUDED
#368287	LINEAR	4 DOTS	OPTION



#368051
ALU SHOCK CAP-NUT WITH VENT HOLE (2)



#104004
HUDY AIR VAC - VACUUM PUMP
- 1/10 OFF-ROAD



#368021
ALU SHOCK SPRING RETAINING COLLAR (4)



BAG

06

- 306219 COMPOSITE SET OF SERVO SHIMS (4)
- 352460 PIVOT BALL 5.8 - V3 (10)
- 363240 BALL UNIVERSAL 5.8MM WITH BACKSTOP (2)
- 368010 COMPOSITE SHOCK PARTS
- 368031 SHOCK PISTONS - COMPLETE SET - DERLIN
- 368040 ALU SHOCK ADJUSTABLE NUT (2)
- 368140 ALU LOWER SHOCK BODY CAP (2)
- 368186 FRONT SPRING-SET - 4 DOTS (2)
- 368200 REAR SHOCK ABSORBERS COMPLETE SET (2)
- 368220 ALU SHOCK BODY - HARD COATED (2)
- 368221 XT2 ALU REAR SHOCK BODY - HARD COATED (2)
- 368260 HARDENED SHOCK SHAFT (2)
- 368261 XT2 REAR HARDENED SHOCK SHAFT (2)
- 368286 REAR SPRING-SET LINEAR - 3 DOTS (2)

- 902205 HEX SCREW SH M2x5 (10)
- 965023 E-CLIP 2.3 (10)
- 970080 O-RING 8x1 (10)
- 970120 O-RING 12 x 1.0 (10)
- 970140 O-RING 14 x 1.5 (10)
- 972031 SILICONE O-RING 3x2.1 (10)

7. SHOCK ABSORBERS

965023
C 2.3

970080
O 8x1

972031
O 3x2.1

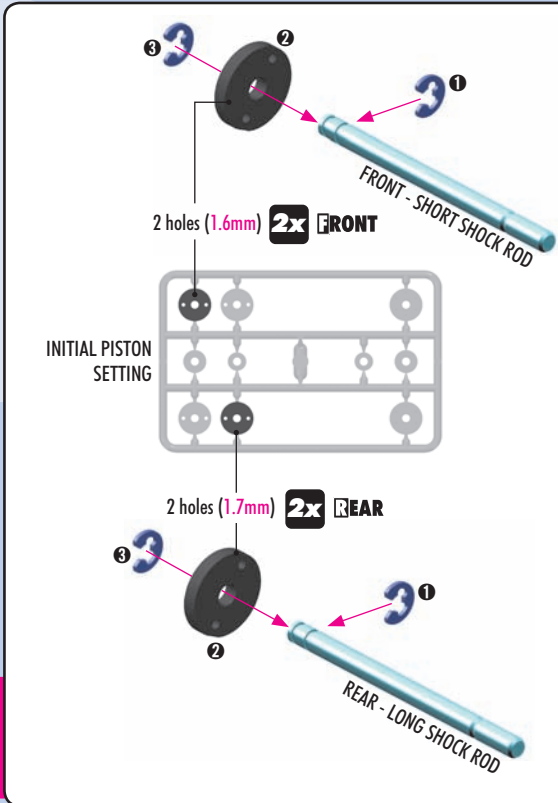

4x

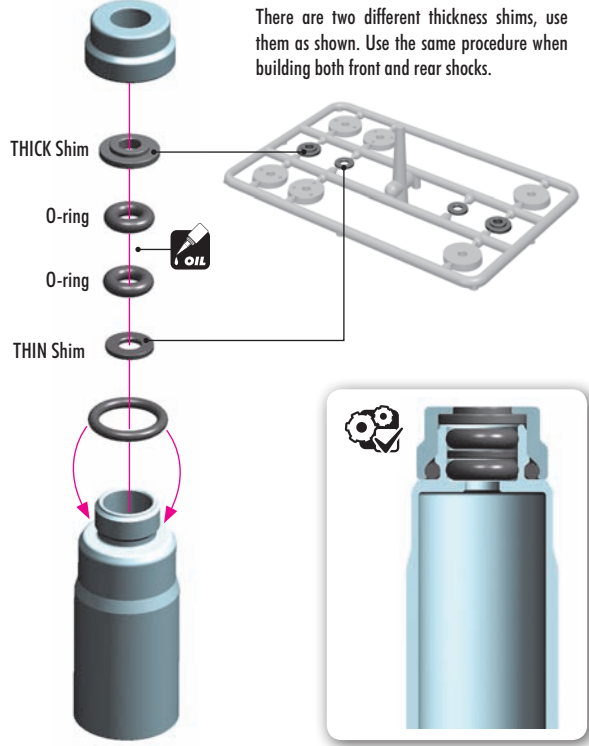

SET-UP BOOK
SHOCK DAMPING
SHOCK PISTONS

306219
SHIM 3x6x2

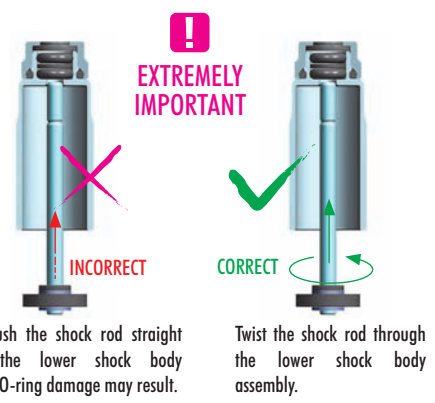
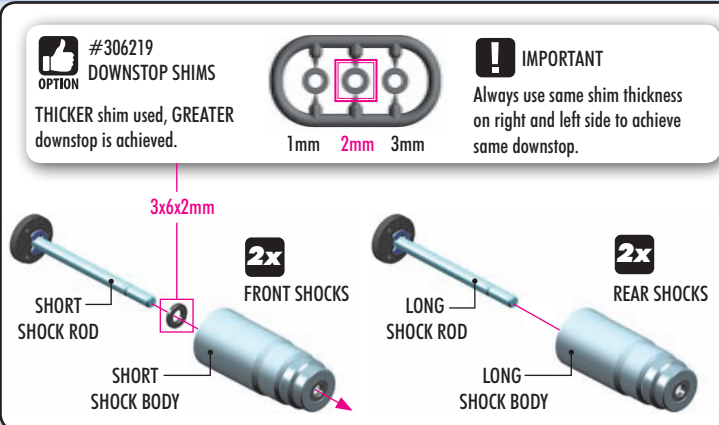

970140
O 14x1.5

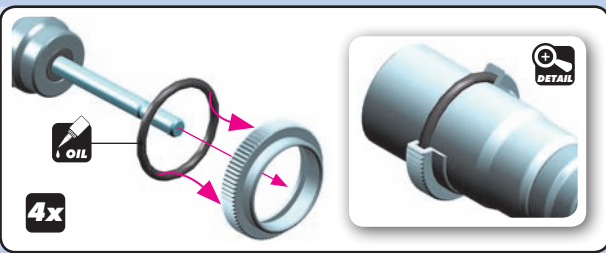

970120
O 12x1

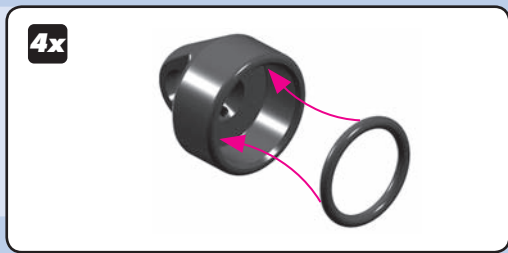

306219
SHIM 3x6x2

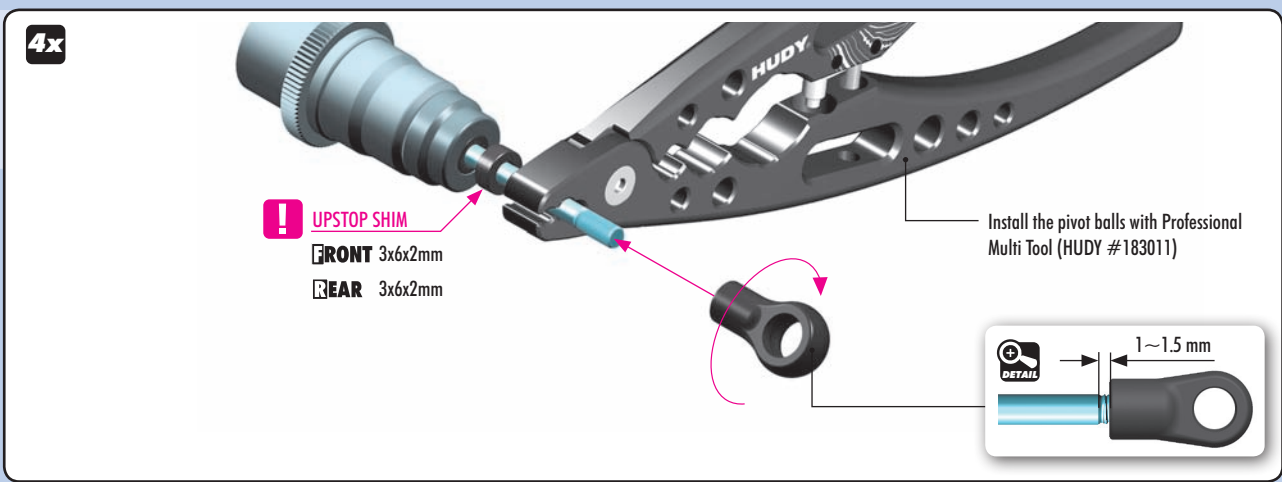

7. SHOCK ABSORBERS



DEFAULT SHOCK REBOUND SETTING 0% REBOUND

Follow the steps below to set the shock rebound to the default setting of 0%.

- 2x** FRONT (SHORT)
Oil 650cSt
- 2x** REAR (LONG)
Oil 450cSt



1 Extend the shock shaft completely. Fill the shock body with the shock oil. For the FRONT shocks (short) use 650cSt oil. For the REAR shocks (long) use 450cSt oil.



2 Move the shock shaft up and down a few times to release the air bubbles trapped beneath the piston.



3 Orient the filled shock vertically for several minutes with the shock shaft fully extended. The remaining air bubbles will release.

TIGHTEN FULLY



4 Gently place the shock cap onto the filled shock body and start to tighten the cap. Tighten the cap fully.



5 Gently push the shock shaft completely into the shock body. Excess oil will flow through the hole in the shock cap.



6 Keep the shock shaft pushed in the shock body and insert the screw into the shock cap. Tighten gently.



7 6x push the shaft up and down.



8 Untighten the screw.



9 Gently push the shock shaft completely into the shock body. Excess oil will flow through the hole in the shock cap.



10 Tighten the screw. The rebound will be at approx. 0%.

SET-UP BOOK
SHOCK OIL

SHORT FRONT SHOCKS **2x** Short Springs **2x** LONG REAR SHOCKS Long Springs

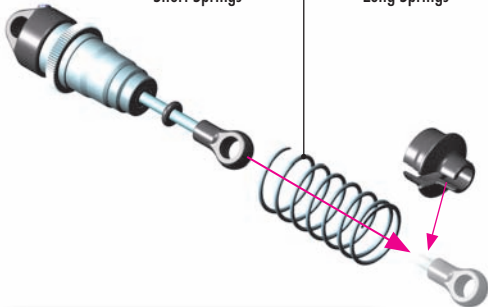

#368021
ALU SHOCK SPRING RETAINING COLLAR (4)
OPTION



! IMPORTANT

Both FRONT SHOCKS must be the same overall length.
Both REAR SHOCKS must be the same overall length.

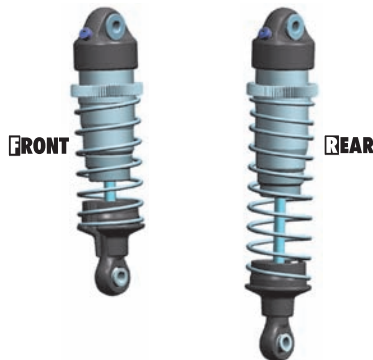

2x FRONT SHOCKS (SHORT)

2x REAR SHOCKS (LONG)

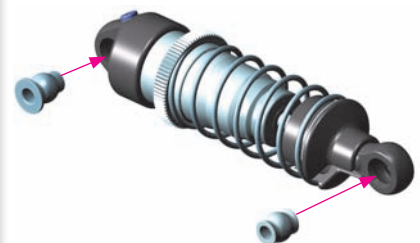

8. FINAL ASSEMBLY

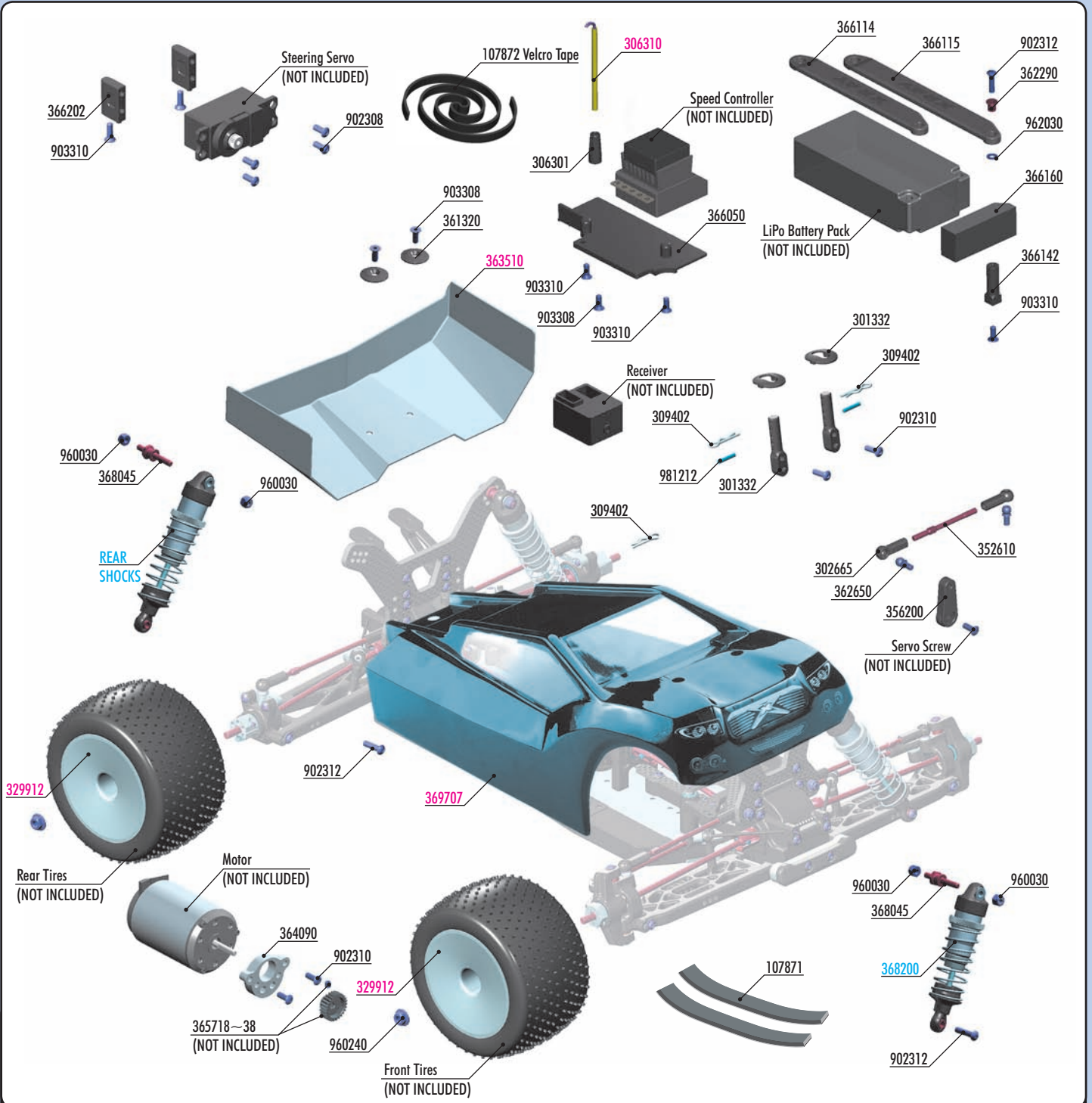

BAG

08

- | | | | |
|-----------|---|--------|--|
| 107871 | HUDY SELF-ADHESIVE FOAM STRIP (2) | 902308 | HEX SCREW SH M3x8 (10) |
| 107872 | VELCRO TAPE WITH DOUBLE SIDED TAPE 8x500MM | 902310 | HEX SCREW SH M3x10 (10) |
| 301332 | REAR BODY MOUNT SET 6MM | 902312 | HEX SCREW SH M3x12 (10) |
| 302665 | COMPOSITE BALL JOINT 4.9MM - CLOSED WITH HOLE (4) | 903308 | HEX SCREW SFH M3x8 (10) |
| 306301 | ANTENNA MOUNT - THIN | 903310 | HEX SCREW SFH M3x10 (10) |
| 309402 | BODY CLIP FOR 6MM BODY POST (4) | 960030 | NUT M3 (10) |
| 352610 | ADJ. TURNBUCKLE M3 L/R 45 MM - SPRING STEEL™ (2) | 962030 | WASHER S 3x6x0.3 (10) |
| 356200 | BRAKE/THROTTLE ARMS & STEERING SERVO ARMS - SET | 960240 | NUT M4 WITH SERRATED FLANGE (10) |
| 361320 | BODY MOUNT, BATTERY MOUNT - V2 & WING SHIM (2) | 981212 | PIN 2x12 (10) |
| 362290 | STEEL STEERING BUSHING - SHORT (2) | 368200 | SHOCK ABSORBERS COMPLETE SET (2) |
| 362650 | BALL END 4.9MM WITH THREAD 6MM (2) | 306310 | ANTENNA (2) |
| 364090 | ALU ECCENTRIC MOTOR BULKHEAD INSERT | 363510 | LEXAN REAR WING (2) |
| 365718~38 | ALU PINION GEAR HARD COATED 18~38T/48 (OPTION) | 369707 | XRAY XT4 BODY |
| 366050 | COMPOSITE RADIO PLATE - V2 | 329912 | STADIUM TRUCK WHEEL AERODISK WITH 12MM HEX - WHITE (2) |
| 366114 | COMPOSITE BATTERY STRAP - LONG | | |
| 366115 | COMPOSITE BATTERY STRAP - LONG XL | | |
| 366142 | COMPOSITE BATTERY HOLDER STAND (2) | | |
| 366160 | FOAM SPACER FOR BATTERY | | |
| 366202 | COMPOSITE SERVO MOUNT - HIGHER | | |
| 368045 | STEEL SCREW SHOCK PIVOT BALL WITH HEX (2) | | |

8. FINAL ASSEMBLY



960030
N M3



902312
SH M3x12

FRONT SHOCKS

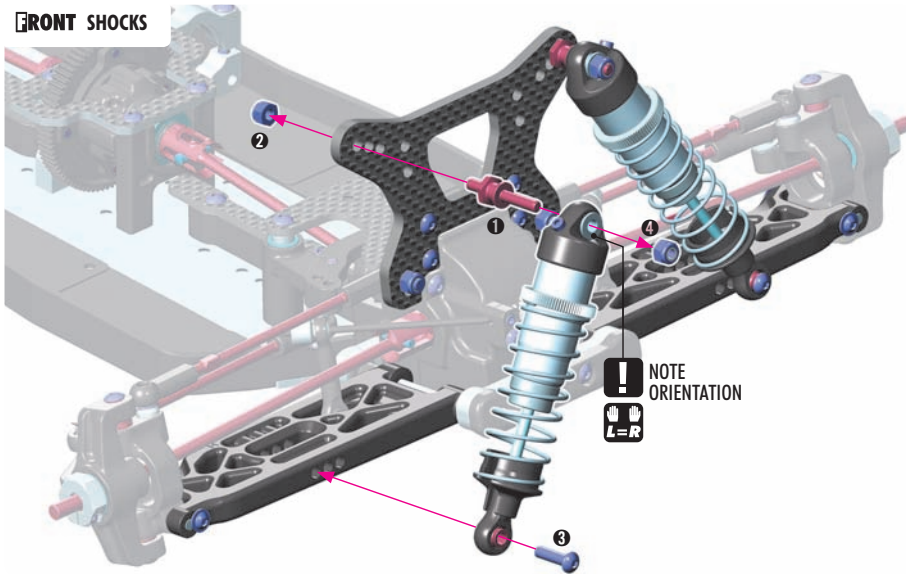

INITIAL POSITION



INITIAL POSITION



ALU NUTS M3			
OPTION	#296530-B	BLUE	OPTION
	#296530-K	BLACK	OPTION
	#296530-O	ORANGE	OPTION
	#960030	STEEL	INCLUDED
	#960031	SILVER	OPTION



960030
N M3



902312
SH M3x12

REAR SHOCKS

ALTERNATIVE 1

SHOCKS MOUNTED IN FRONT OF REAR SHOCK TOWER
(INITIAL SETTING)

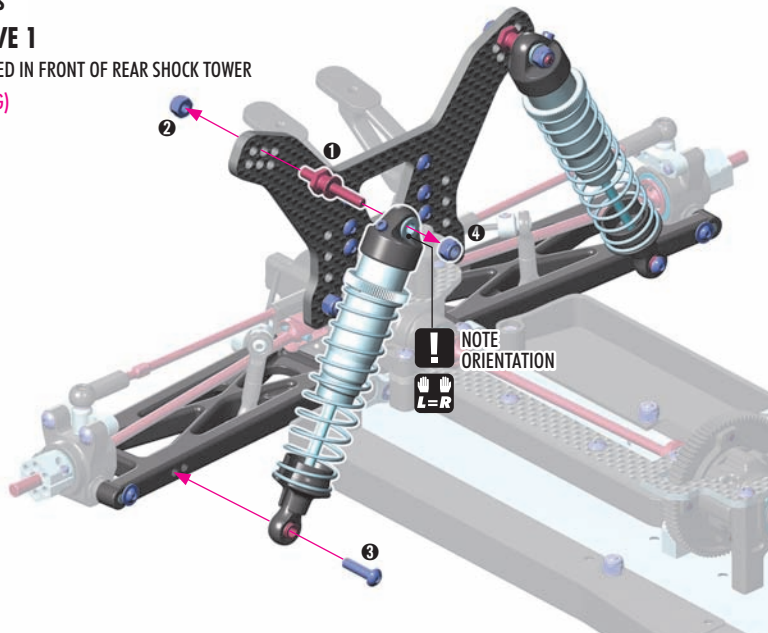

INITIAL POSITION

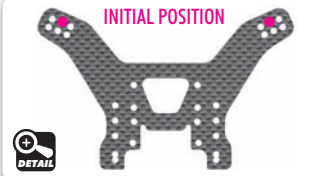

INITIAL POSITION

REAR SHOCKS

ALTERNATIVE 2

SHOCKS MOUNTED BEHIND REAR SHOCK TOWER
DO NOT USE FOR BASIC SET-UP

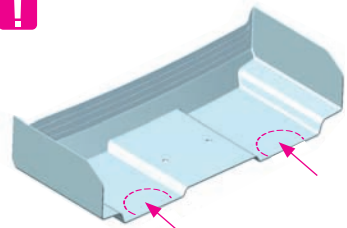
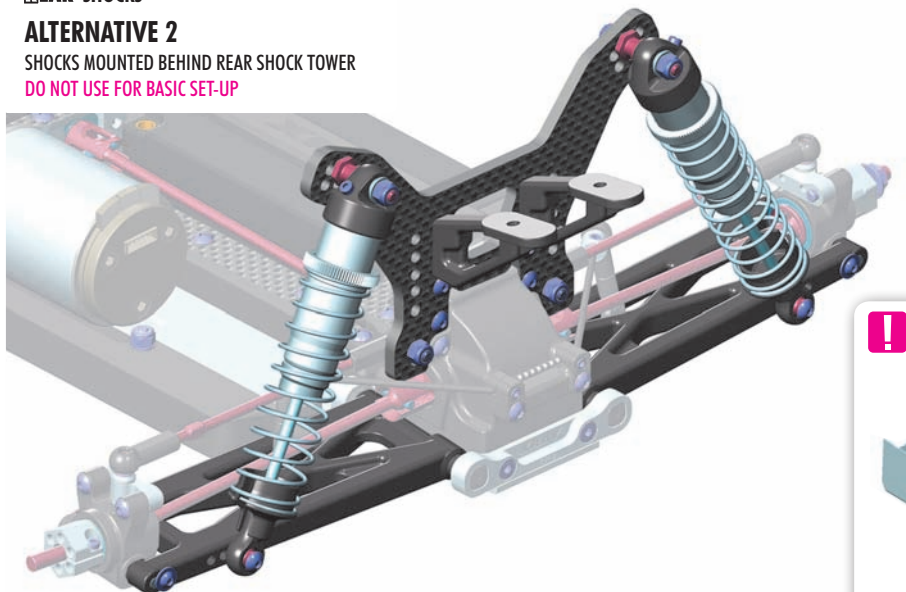

For the rear shock position cut holes into the Lexan rear wing.

8. FINAL ASSEMBLY

SERVO LINK
Adjust servo link to fit your servo.

TIP Install the pivot balls with Professional Multi Tool (HUDY #183011)

902308
SH M3x8

Servo (NOT INCLUDED)

NOTE ORIENTATION

Market "K-H-F"

Servo screw (NOT INCLUDED)

Use appropriate servo arm:
K - (23T) KO Propo / JR / Sanwa / Multiplex
H - (24T) Hitec
F - (25T) Futaba / Savox

OPTION

HUDY ALU SERVO HORNS	
#293497	23T
#293498	24T
#293499	25T

OPTION

HUDY CLAMP ALU SERVO HORNS	
#293404	23T
#293405	24T
#293406	25T

For more in-corner steering and better steering response, aluminum servo horns may be used.

OPTION

#366220
INDEPENDENT SERVO MOUNT - SET

903310
SFH M3x10

FRONT

8. FINAL ASSEMBLY



902310
SH M3x10



OPTION

PINIONS

#365718	18T / 48P
#365719	19T / 48P
#365720	20T / 48P
#365721	21T / 48P
#365722	22T / 48P
#365723	23T / 48P
#365724	24T / 48P
#365725	25T / 48P
#365726	26T / 48P
#365727	27T / 48P
#365728	28T / 48P
#365729	29T / 48P
#365730	30T / 48P
#365731	31T / 48P
#365732	32T / 48P
#365733	33T / 48P
#365734	34T / 48P
#365735	35T / 48P
#365736	36T / 48P
#365737	37T / 48P
#365738	38T / 48P

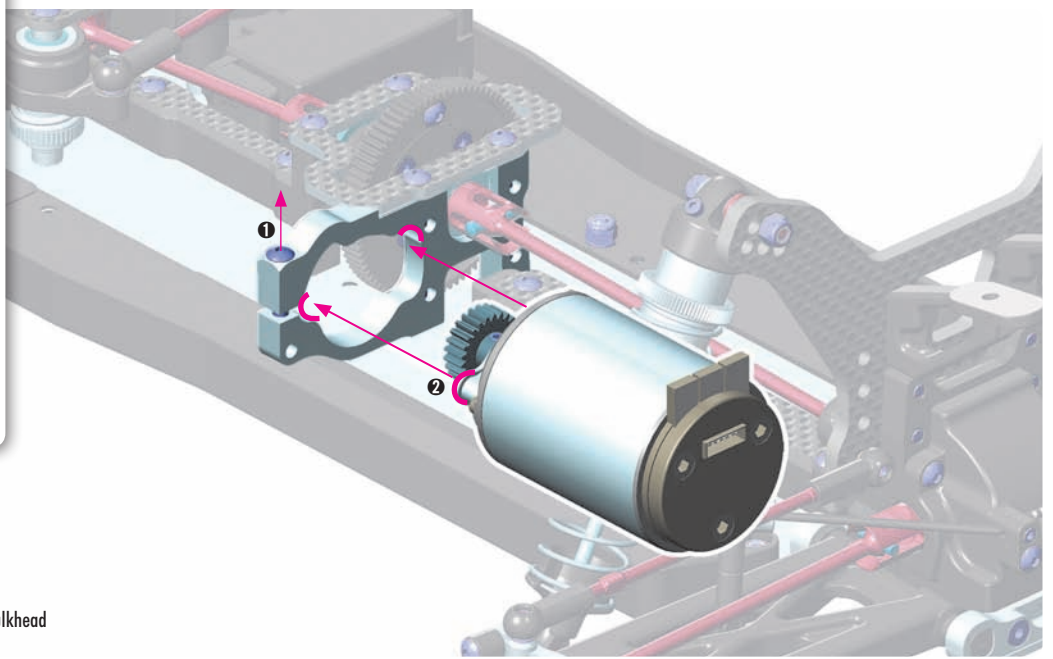
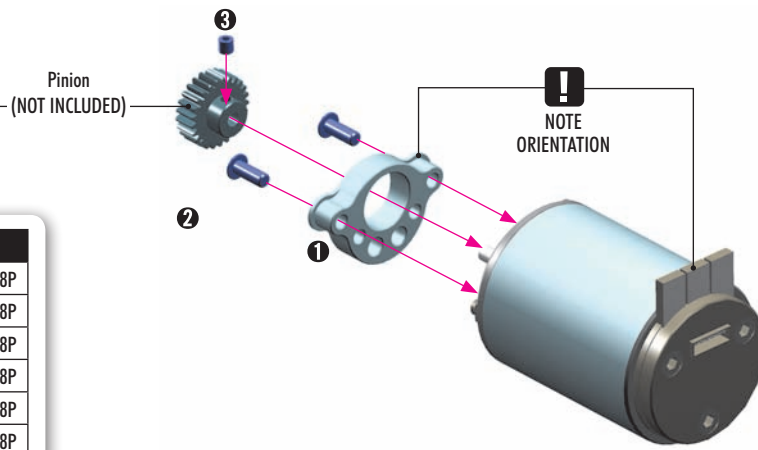

NOTE

- ① Loosen the screw
- ② Insert motor into the bulkhead

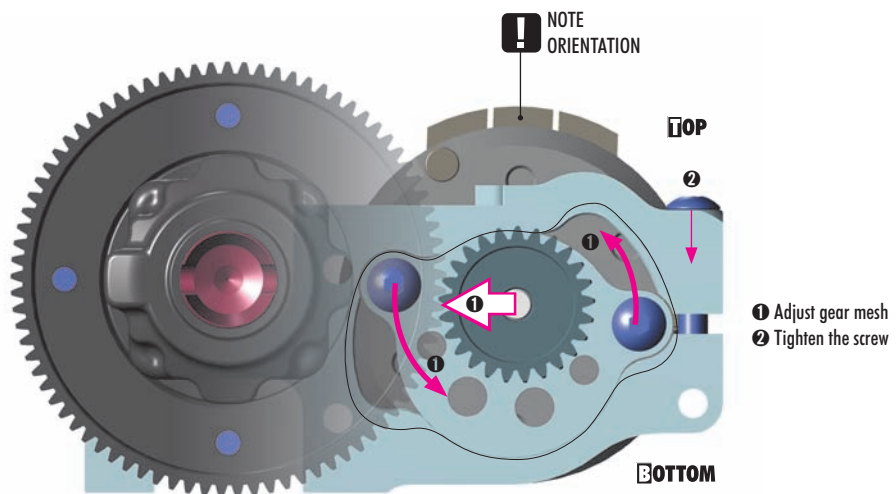

Adjust the motor so the pinion meshes with the spur gear properly. Make sure the gear mesh is not too tight.

There should be a small amount of play between the teeth of the pinion gear and the spur gear.

8. FINAL ASSEMBLY



903308
SFH M3x8

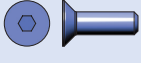

903310
SFH M3x10

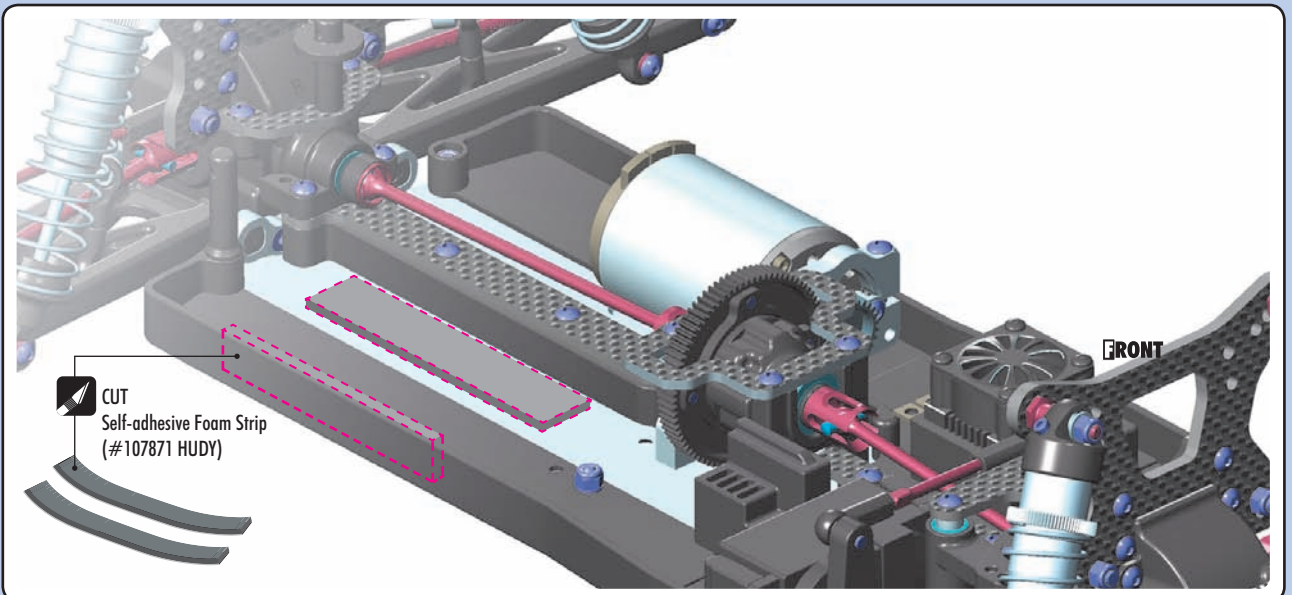
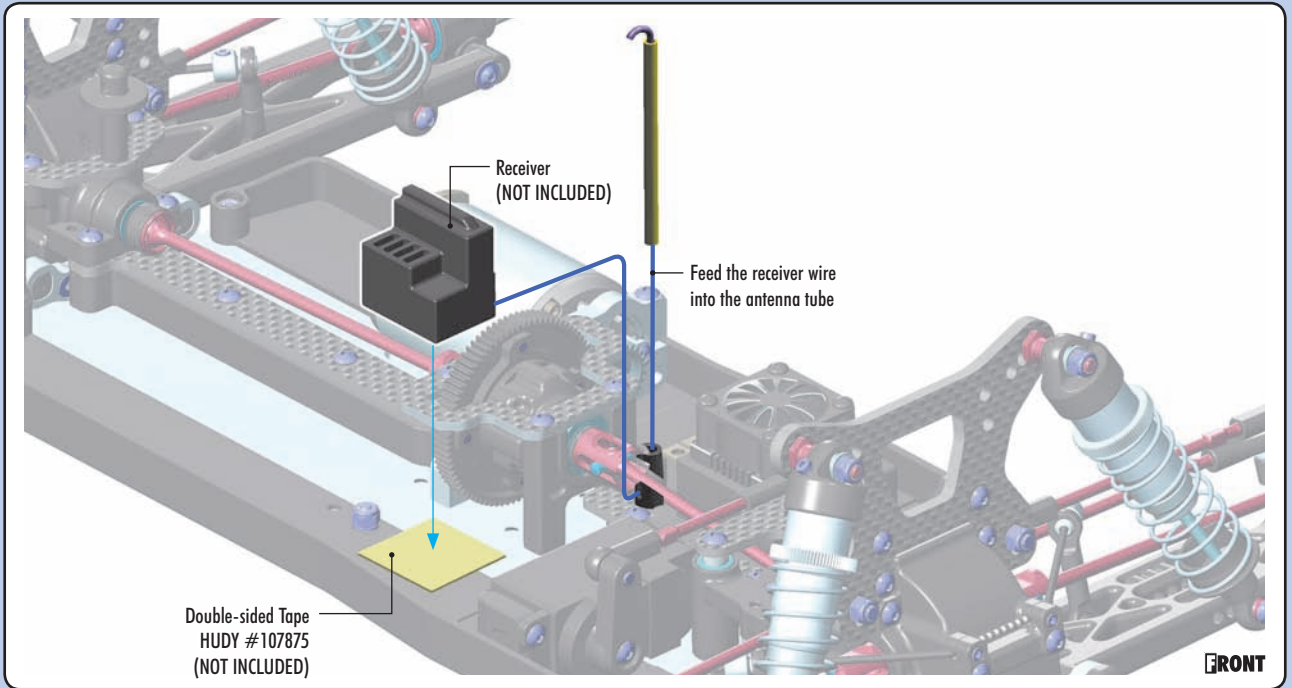
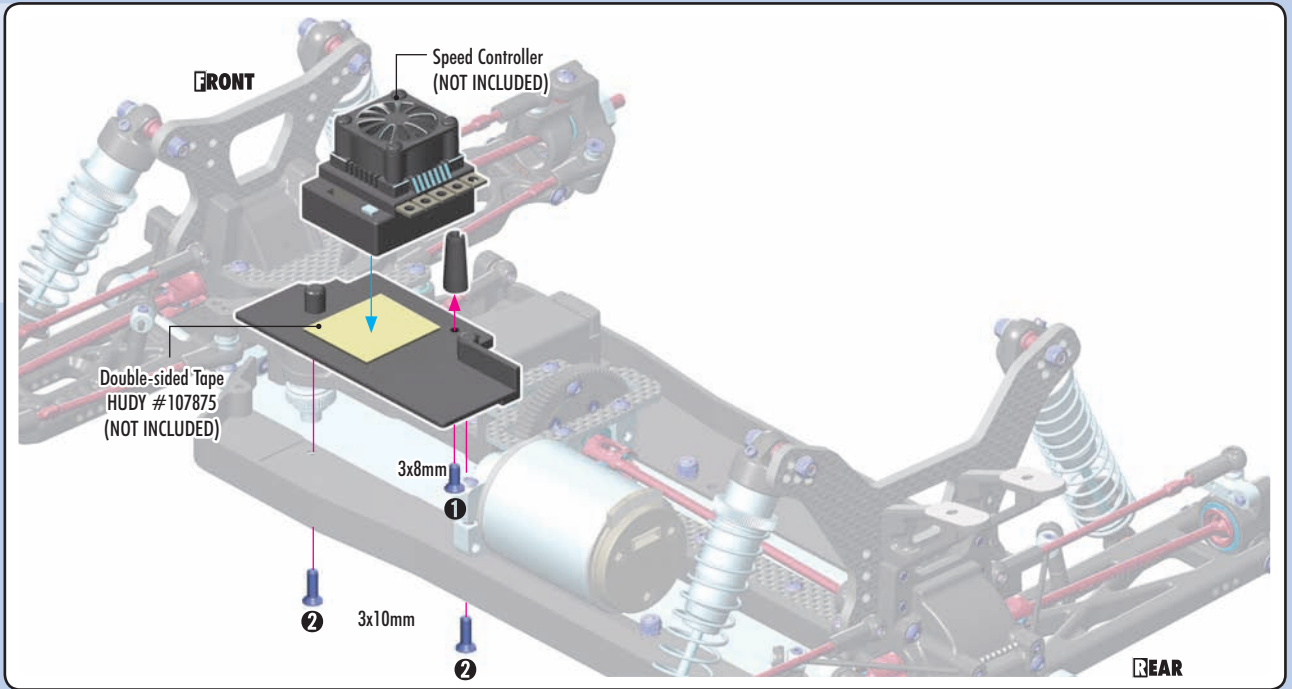

8. FINAL ASSEMBLY



ALTERNATIVE 1

FORWARD WEIGHT BALANCE POSITION
(INITIAL SETTING)

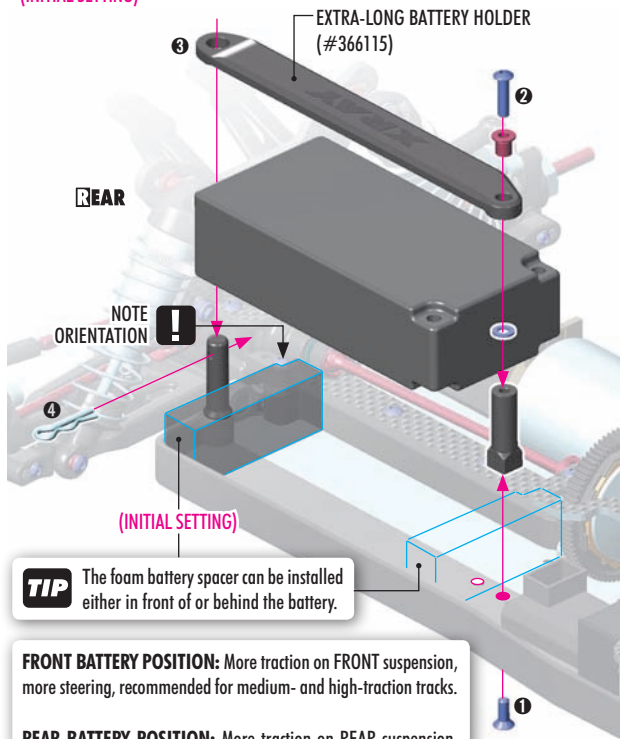

TIP The foam battery spacer can be installed either in front of or behind the battery.

FRONT BATTERY POSITION: More traction on FRONT suspension, more steering, recommended for medium- and high-traction tracks.

REAR BATTERY POSITION: More traction on REAR suspension, more stable, recommended for medium- and low-traction tracks.

ALTERNATIVE 2

REARWARD WEIGHT BALANCE POSITION

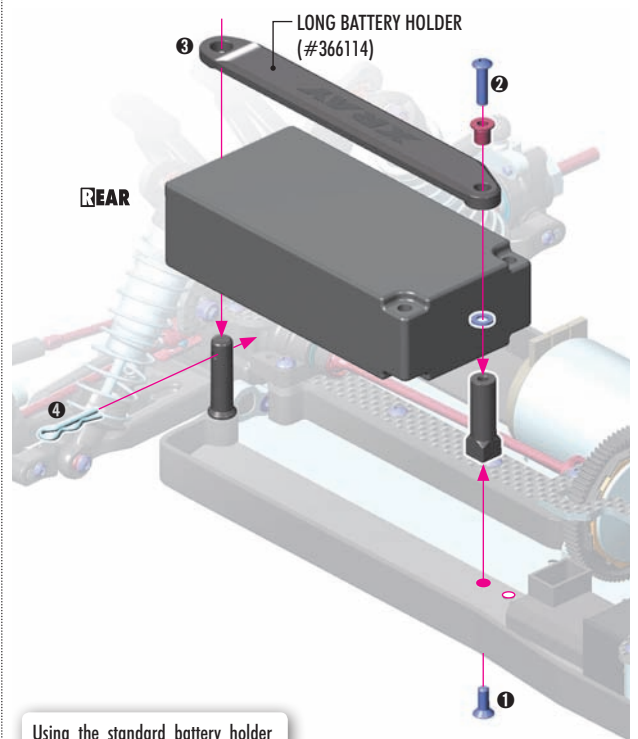

Using the standard battery holder positions the battery to the REAR.

- Before cutting and making holes on the BODY, put the unpainted body on the chassis to confirm the mounting position and location for holes and cutouts. Before cutting and making holes on the WING, put the unpainted wing on the wing holders to confirm the mounting position and location for holes and cutouts.
- Before painting, wash the inside of the body with mild detergent, and then rinse and dry thoroughly.
- Mask all windows.

- Apply paint masks as appropriate.
- Paint the body using paints formulated for polycarbonate bodies.
- When the paint is dry, remove the masking.
- Carefully cut out the body using appropriate scissors or cutting tools.
- When you have finished cutting, peel off the external protective films.

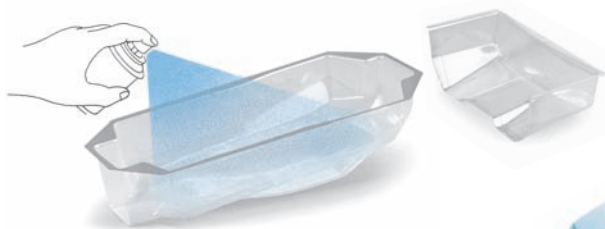

BODY REAMER (HUDY #107600)



#323515
LEXAN REAR WING
CENTER FIN - ZAP (2)

XRAY LEXAN REAR WINGS

#323510	1.0mm		OPTION
#323511	1.5mm		OPTION
#323513	1.0mm	RANK	OPTION
#323517	1.0mm	TEC	OPTION
#363510	1.0mm		INCLUDED
#363511	1.5mm		OPTION
#363512	2.0mm		OPTION

WING CUTTING LINE OPTIONS

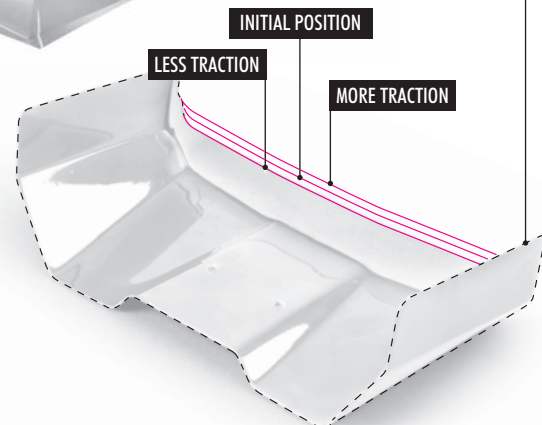

8. FINAL ASSEMBLY



902310
SH M3x10



981212
P 2x12

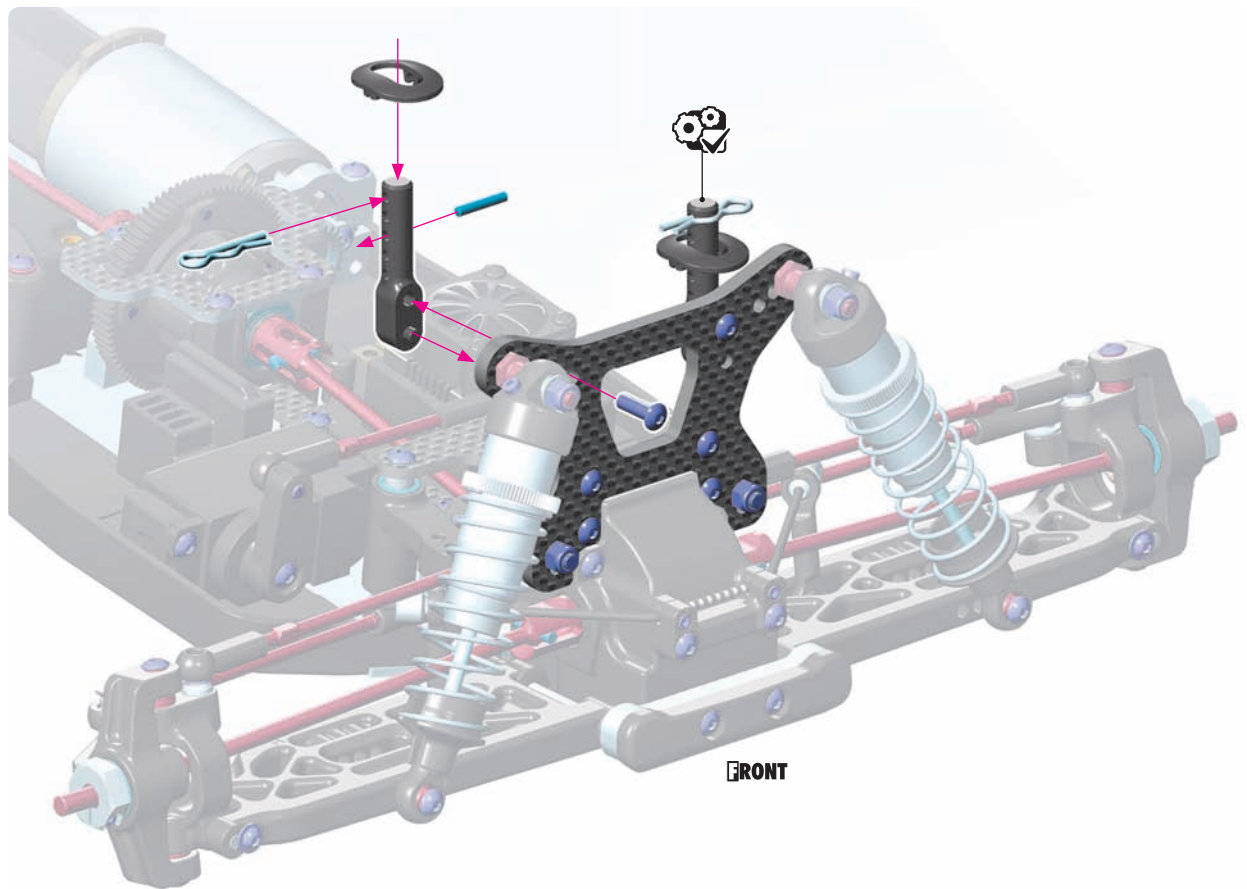

2x  **L=R**

Double-sided Velcro™ tape is used to seal the body against the side guards.

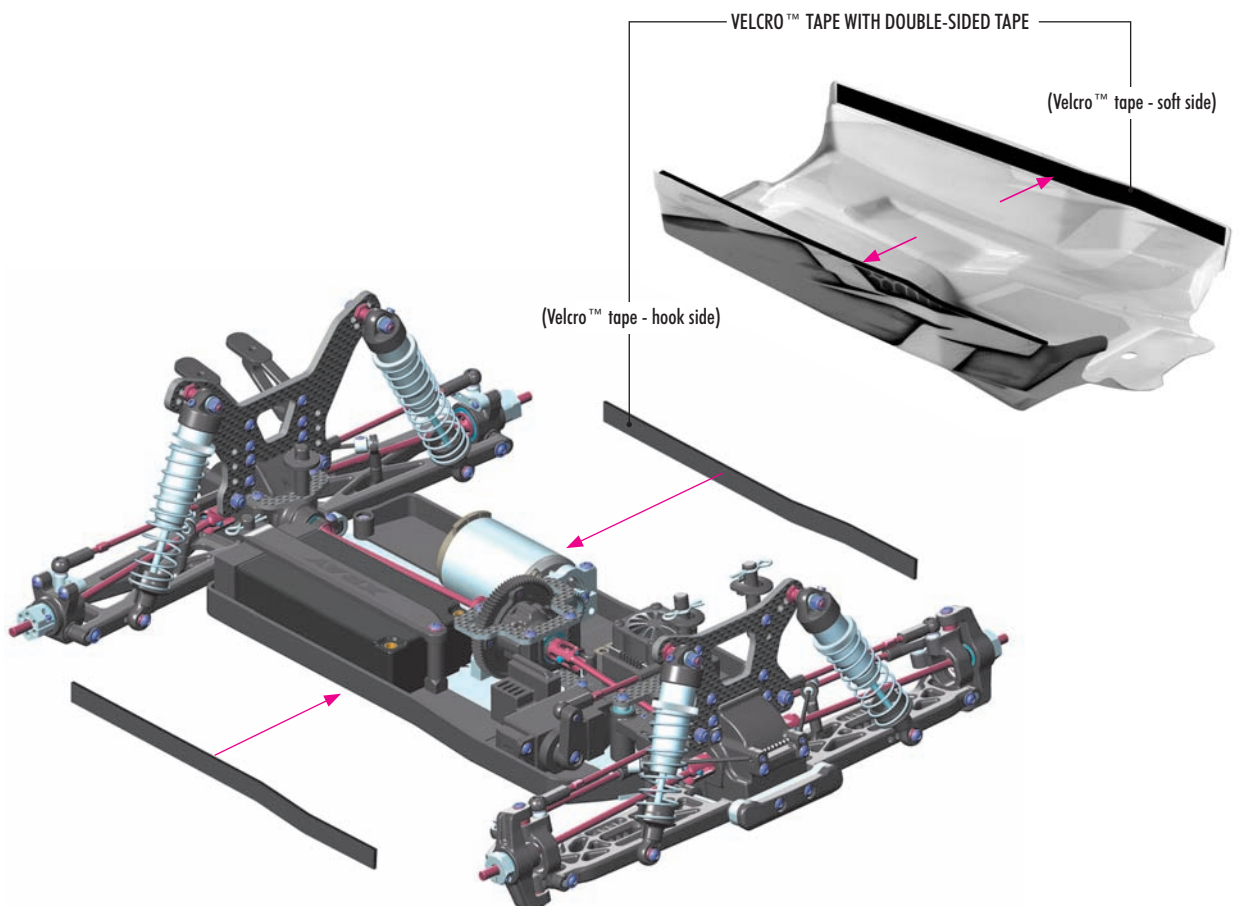

8. FINAL ASSEMBLY



960240
N M4

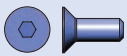
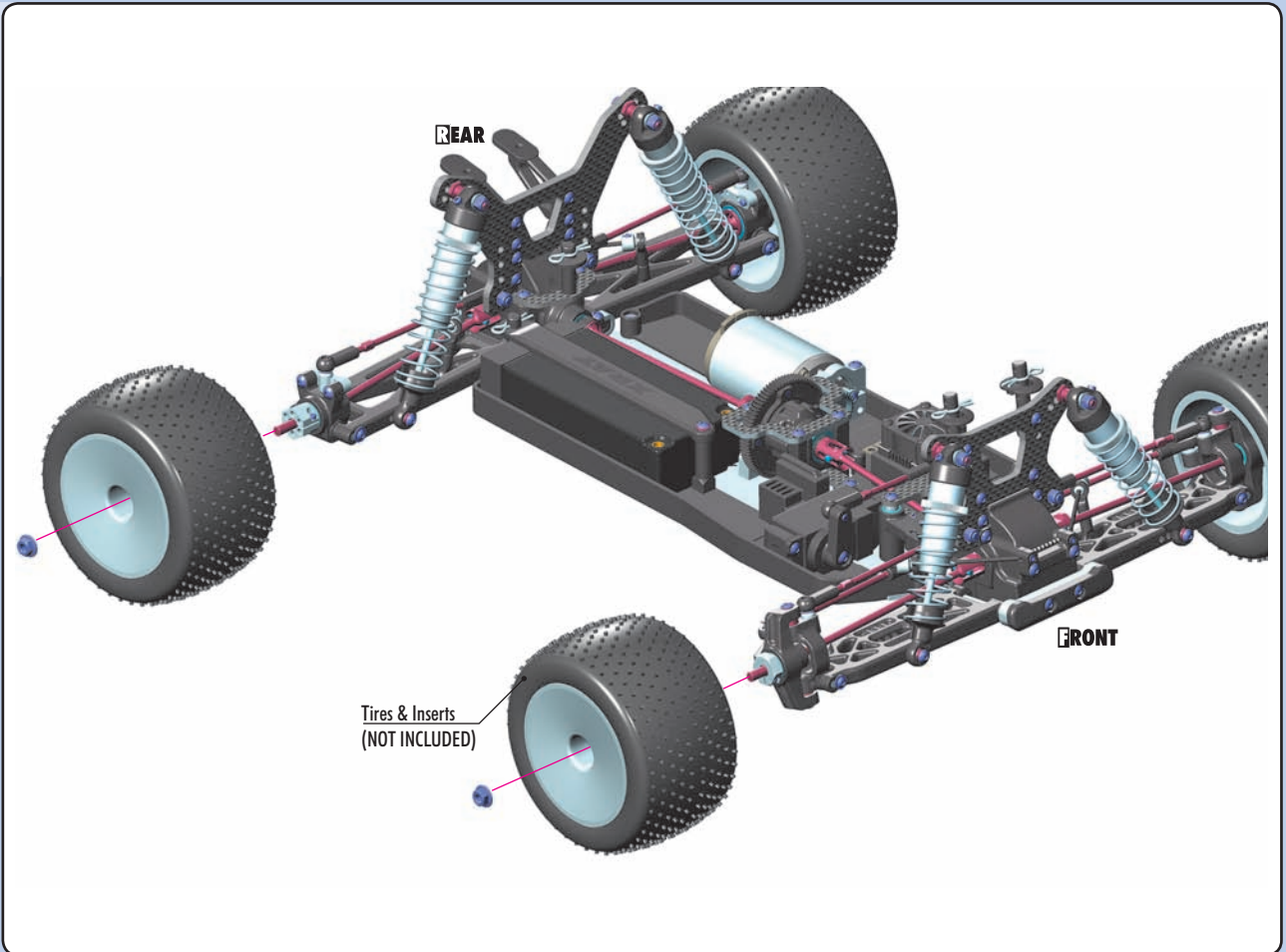

903308
SFH M3x8



OPTIONAL ALU WING SHIMS

#293561	SILVER	OPTION	
#293561-0	ORANGE	OPTION	

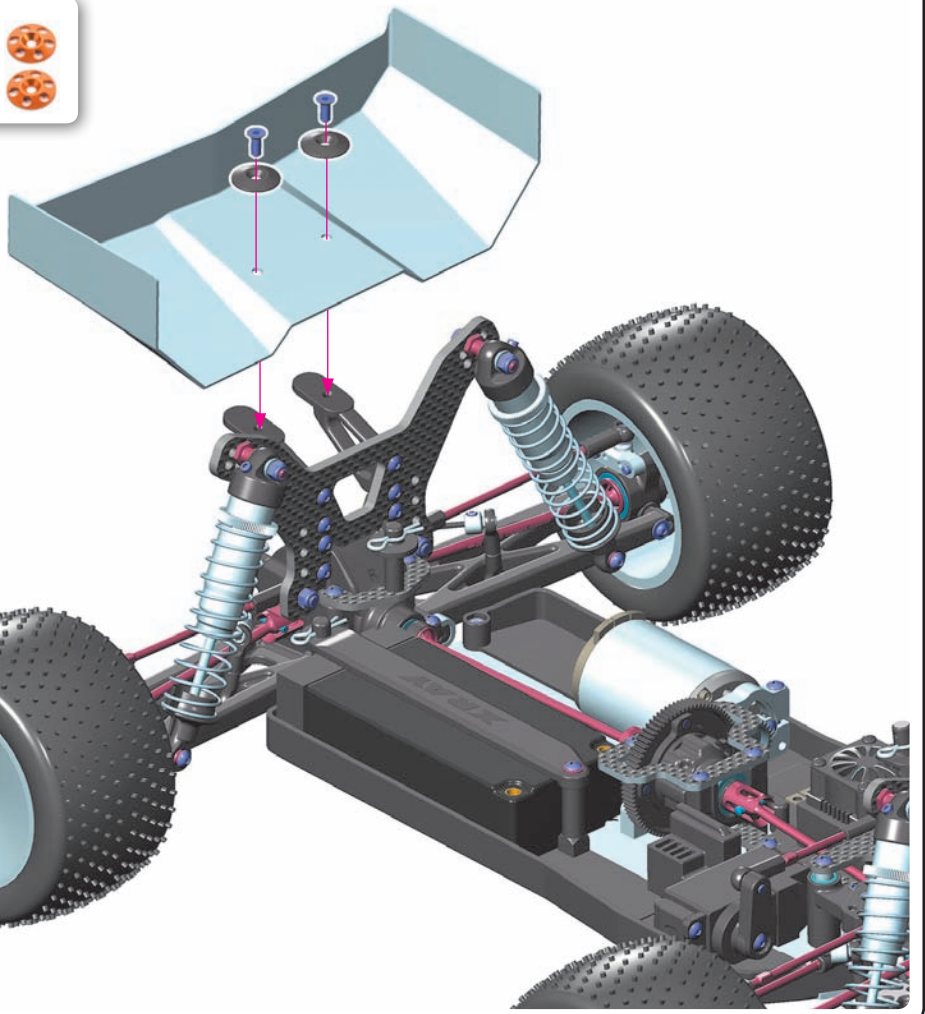

SHOCK MAINTENANCE

The most important maintenance task for keeping consistent shock performance is refilling and bleeding them correctly. If built correctly, it will not be necessary to re-build them often. Replacing warped/hard o-rings, scarred piston rods, or shaved/split/loose composite upper and lower ball joints are also important.

- For club racing, it is recommended to check the shocks for air inside before each race and only re-fill and bleed them if necessary. Before each race day, make sure you take the spring off of each shock, hold it up to your ear, and quickly compress the shock rod fully into the body while listening for any air making a "whistling" or "squishy" sound as it passes through the piston holes. If you hear any air, refill and bleed your shocks. For high-competition racing, it is recommended that the shocks be re-filled and bled before a large event.
- If building or pairing new shocks, always make sure they are the same length using a shock length measuring tool and adjust the lower ball joints as needed.
- During regular shock operation, oil naturally gets on the shock shaft and drop-by-drop slightly gets out of the shock body. Shocks should be inspected regularly after each race, and oil replaced as required.

BEARING MAINTENANCE

Ball-bearings in an off-road car must be properly maintained for smooth operation and long lifespan.

The XB4 ball-bearings are degreased and are lubricated with HUDY Bearing Oil or HUDY Grease. The following procedures are recommended to clean all of the bearings in your off-road car. For high-competition racing, we recommended doing this every 3-4 weeks, or before a major race.

- 1 Remove the seals on both sides of the bearing (if present). If the seals bend a little and you can see a kink, carefully flatten the kink out by hand.
- 2 Spray the seals with motor cleaner and blow dry with compressed air.
- 3 Spray the bearing on both sides with motor cleaner.
- 4 Spin the bearing while it is still wet to dislodge any particles with the cleaner.
- 5 Spray the bearing on both sides again.
- 6 Blow both sides of the bearing dry with compressed air to make sure particles come out.
- 7 Hold the inner part of the bearing with my left thumb/forefinger and spin it to make sure it spins free without any abnormal vibrations or sounds.
- 8 Place one drop of bearing oil into each side of the bearing.
- 9 Replace both seals at the same time by lining them up on each side of the bearing and lightly pressing them in all the way around the bearings circumference with your thumb and forefinger. Do not press too hard or use any type of tool, such as a wrench tip, to push the blue seals in as they will push in too far, bend and cause drag.

If you spin test the bearing after you have re-oiled and sealed it, it will not spin freely for an extended period of time. The lightest of oils may allow it to spin for 1-2 seconds. This is normal and once you have mounted the bearings in the car again, the drive train will spin freely.

Make sure you use a motor cleaner that does not leave a residue after it dries as this may cause drag and wear in the bearings.

RECOMMENDED PRODUCTS

- Use correct oil or grease to lubricate the bearings:
 #106230 HUDY Bearing Oil
 #106220 HUDY Bearing Grease - Standard
 #106221 HUDY Bearing Grease - Blue
 #106222 HUDY Bearing Grease - Red



SUSPENSION & DRIVETRAIN MAINTENANCE

- Check suspension for free movement during building and operation, and especially after running and if you have crashed the car. If the suspension does not move freely, use the appropriate HUDY Arm Reamer to clean and resize the holes of the suspension arms.
- Regularly check the drive shaft pins (both side and center) and if they show any wear must be immediately replaced by new pins. If the car is run with worn pins, excessive wear on the diff outdrives will result. The #106000 HUDY Drive Pin Replacement Tool (for 3mm Pins) is a compact, rugged multi-use tool set for replacing 3mm drive pins in drive shafts. Use the HUDY replacement drive shaft pins 3x12 (#106051).
- Regularly inspect and replace the connecting pins which connect the center drive shafts with the pinion gear, and also the pins that connect the wheel drive shafts with wheel axles. Use HUDY Graphite Grease to lubricate the drive shaft connecting joints and the diff gears.
- Pivot balls and ball-joints will naturally wear for some time and will generate play. If there is too much play the pivot balls and ball joints need to be replaced.
- If the car is run in wet conditions, apply WD-40® on all drivetrain parts before the run. After the run, clean and dry the parts again.



#106210 HUDY GRAPHITE GREASE or #106213 HUDY JOINT GREASE

HUDY SPRING STEEL™

The HUDY Spring Steel™ used in the car is the strongest and most durable steel material on the RC market. While items made from HUDY Spring Steel™ are still subject to wear, the lifespan is considerably longer than any other material. As parts made from HUDY Spring Steel™ wear, the

brown color will fade (get lighter) but it will not affect the strength of the material. The brown color is only a surface treatment and if the brown color will wear the durability of the part will be still strong.

NOTE

www.teamxray.com

XRAY EUROPE

XRAY, K VÝSTAVISKU 6992, 91101 TRENCIN, SLOVAKIA, EUROPE
PHONE: +421-32-740 11 00, FAX: +421-32-740 11 09, info@teamxray.com

XRAY USA

RC AMERICA, 2030 Century Center Blvd #15, Irving, TX 75062, USA
PHONE: 214-744-2400, FAX: 214-744-2401, xray@rcamerica.com



/TeamXray



/TeamXray



/TeamXray



/TeamXrayRC



/XrayRacing



/XrayRacing