



Instruction Manual Book

Item code: BH162.

TURBO BEAVER

ALL BALSA - PLY WOOD CONSTRUCTION.
COVERED WITH ORACOVER®

95% PRE BUILT
ARF
ALMOST READY TO FLY



95% ALMOST READY TO FLY

SPECIFICATION:

- Wingspan: 2,250 mm (88.58 in).
- Length: 1,675 mm (65.94 in).
- Weight: 5.5kg (12.1lbs).
- Wing area: 59.7 dm².
- Wing loading: 92.1g/dm².
- Wing type: USA 35-B Airfoil.
- Servo mount: 42mm x 21mm.
- Gear type: Aluminium Hi-grade for main gear and spring wire for tail gear (included).

Parts listing required (not included):

- Radio: 06 channels.
- Servo: 08 servos.
- Engine: 120 - 2 stroke, 20 - 30cc gas.
- Motor: Brushless outrunner 1800-2300W, 450KV.
- Propeller: Suit with your engine.

Recommended motor and battery set up (not included):

- Motor: RIMFIRE.120.z
- Lipo cell: 6 cells 4,000-5,000mAh.
- ESC: 80A.
- Receiver battery: 6V/ 1200-2000mAh NiMH.

This instruction manual is designed to help you build a great flying aeroplane. Please read this manual thoroughly before starting assembly of your **TURBO BEAVER**. Use the parts listing below to identify all parts.

WARNING

Please be aware that this aeroplane is not a toy and if assembled or used incorrectly it is capable of causing injury to people or property. WHEN YOU FLY THIS AEROPLANE YOU ASSUME ALL RISK & RESPONSIBILITY.

If you are inexperienced with basic R/C flight we strongly recommend you contact your R/C supplier and join your local R/C Model Flying Club. R/C Model Flying Clubs offer a variety of training procedures designed to help the new pilot on his way to successful R/C flight. They will also be able to advise on any insurance and safety regulations that may apply.

SUGGESTION

To avoid scratching your new airplane, do not unwrap the pieces until they are needed for assembly. Cover your workbench with an old towel or brown paper, both to protect the aircraft and to protect the table. Keep a couple of jars or bowls handy to hold the small parts after you open the bag.

NOTE

Please trial fit all the parts. Make sure you have the correct parts and that they fit and are aligned properly before gluing! This will assure proper assembly **TURBO BEAVER**. ARF is hand made from natural materials, every plane is unique and minor adjustments may have to be made. However, you should find the fit superior and assembly simple.

The painted and plastic parts used in this kit are fuel proof. However, they are not tolerant of many harsh chemicals including the following: paint thinner, C/A glue accelerator, C/A glue debonder and acetone. Do not let these chemicals come in contact with the colors on the covering and the plastic parts.

Caution: This model is not a toy!

If you are a beginner to this type of powered model, please ask an experienced model flyer for help and support. If you attempt to operate the model without knowing what you are doing you could easily injure yourself or somebody else. Please keep your safety and well-being in mind at all times.

Important: Before you start construction

Even if you have built a large number of RC models

please read right through these instructions and check all the kit components against the parts list. We have taken great trouble to keep construction as simple as possible, without making any compromises in the area of safety.

Note regarding the film covering

Minor creases or bubbles may develop in the film covering due to major fluctuations in weather conditions (temperature, humidity etc.); in rare cases you may even find a slight warp in a component. These minor faults are in the nature of film-covered built-up wooden structures, and can easily be corrected using a heat gun, as commonly used for modelling.

Creases: Blow warm air over the area and rub down with a soft cloth.

Wing wrap: Hold the panel twisted gently in the opposite direction to the wrap, and apply warm air to remove the creases from the covering.

Caution! do not heat the film more than is absolutely necessary. If the air or the iron is too hot, the film may melt and holes may be formed.

This model is highly pre-fabricated and can be built in a very short time. However, the work which you have to carry out is important and must be done carefully. The model will only be strong and fly well if you complete your tasks competently - so please work slowly and accurately.

When self-tapping screws have to be screwed into wood, apply a little white glue to prevent them shaking loose: just squirt white glue into the hole and fit the screw

TOOLS & SUPPLIES NEEDED



Cyanoacrylate Glue.

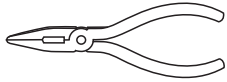

Needle nose Pliers.

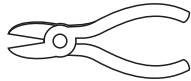

Wire Cutters.



Philip screw driver



Threadlocker (screw cement).



Phillips head screwdriver.

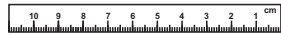

Straight edge ruler.



Epoxy Glue (5 minute type).
Epoxy Glue (30 minute type).

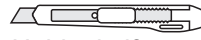

Hobby knife.



Awl.



Hex Wrench.



Hand or electric drill.

Some more tools.

- Assorted drill bits.
- 2mm ball driver.
- 90° square or builder's triangle.
- Masking tape & T-pins.
- Paper towels.

PARTS LISTING



Propeller: Suit with your engine.

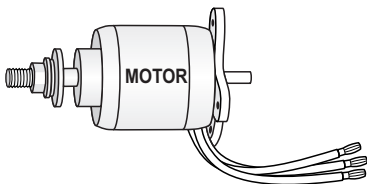

Engine: 20 - 30cc Gas.

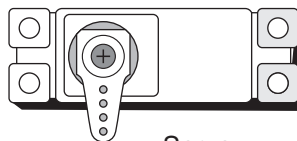
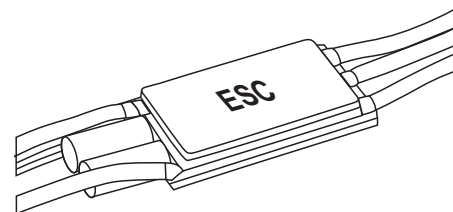
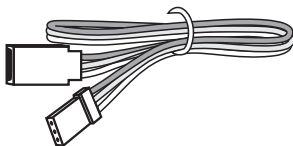
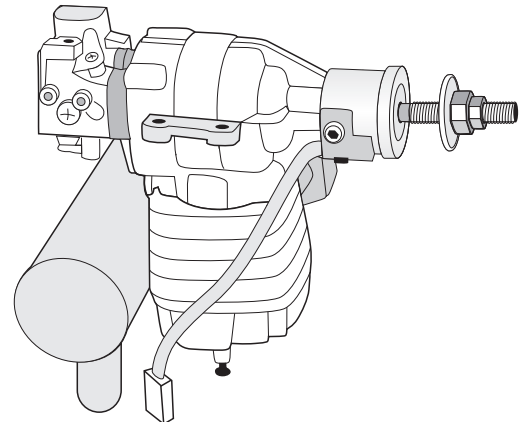

Servo

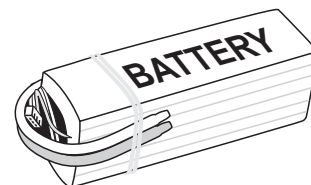

- ❶ : Fuselage.
- ❷ : Wing panel (2a, 2b, 2c, 2d).
- ❸ : Horizontal stabilizer.
- ❹ : Rudder.
- ❺ : Aluminium wing dihedral brace.
- ❻ : Cowling.
- ❼ : Cockpit fuselage (7a, 7b, 7c).
- ❽ : Spinner.
- ❾ : Decal sheet.

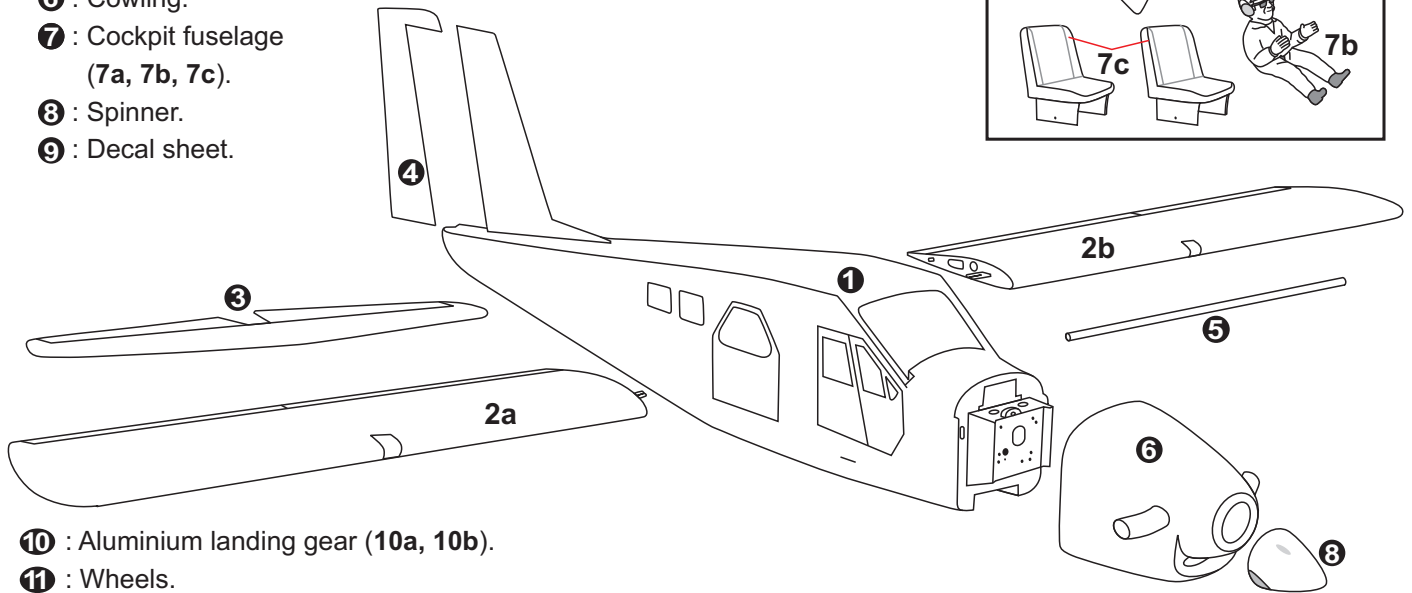
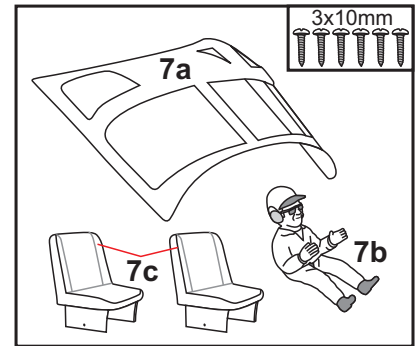

- ❿ : Aluminium landing gear (10a, 10b).
- ⓫ : Wheels.
- ⓬ : Plastic of main gear (12a, 12b).
- ⓭ : Wing struts.
- ⓮ : Fuel Tank (14a : Clunk; 14b : Stopper (three line)).
- ⓯ : Tail gear set.
- ⓰ : Plastic - engine mount (16a, 16b).
- ⓱ : Wood - motor mount.

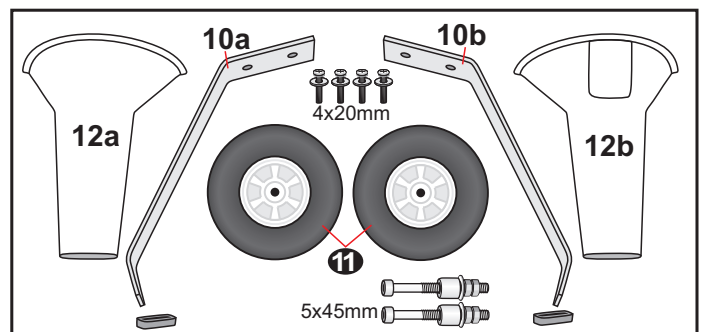
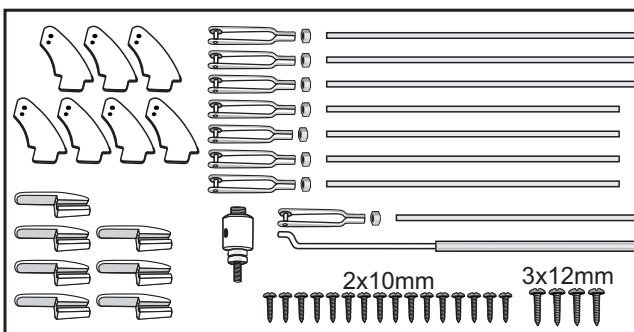
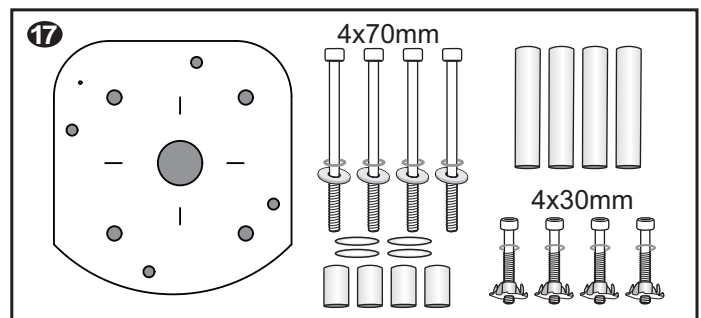
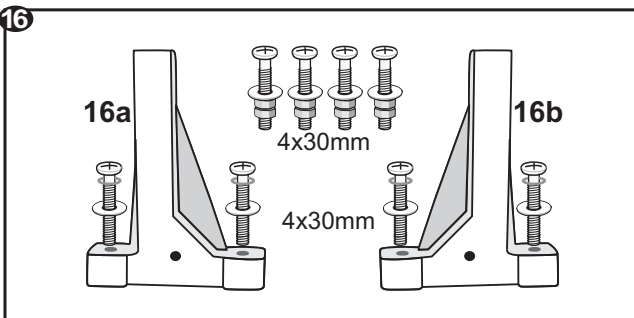
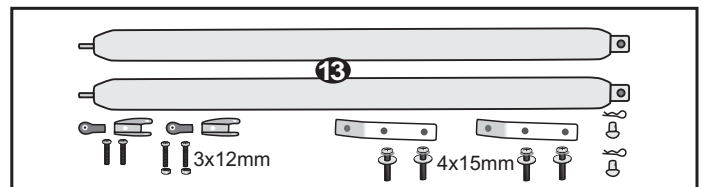
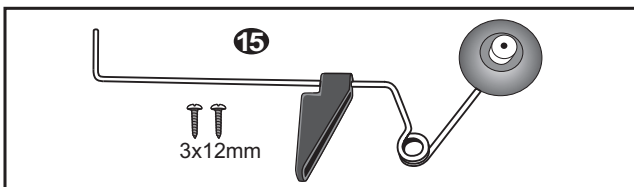

1. INSTALLING THE AILERONS, FLAPS

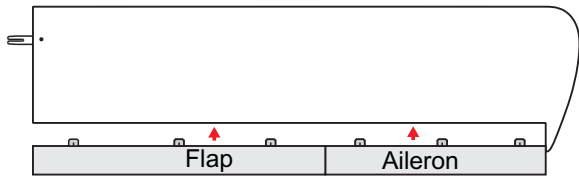

* Test fit the ailerons to the wing with the hinges. If the hinges don't remain centered, stick a pin through the middle of the hinge to hold it in position.

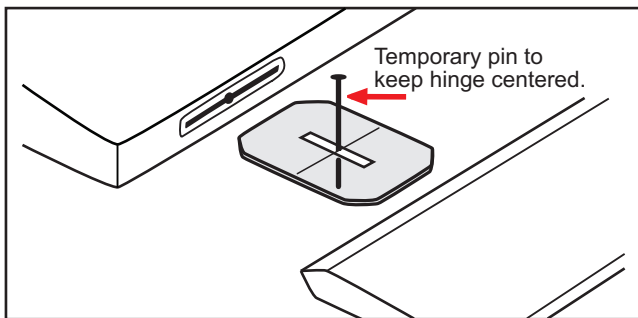

* Apply drops of thin CA to the top and bottom of each hinge. Do not use CA accelerator. After the CA has fully hardened, test the hinges by pulling on the aileron.

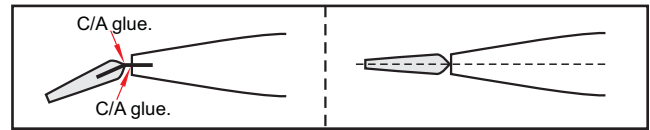

* Secure nylon hinges with instant glue, being careful not to glue the wing and aileron together.
* Align the center line of main wing with aileron.

WARNING Make certain the hinges are adequately secured with glue. If they come loose in flight accidents may result.

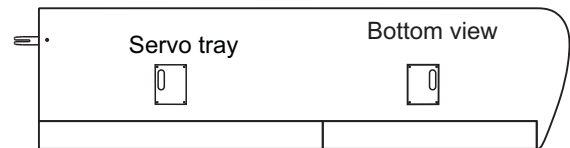

2. INSTALLING THE AILERON SERVOS

* Install the rubber grommets and brass eyelets on to the aileron servos.
* Using a modeling knife, remove the covering from over the pre-cut servo arm exit hole on the aileron servo tray / hatch. This hole will allow the servo arm to pass through when installing the aileron pushrods.
* Place the servo into the servo tray. Center the servo within the tray and drill 1.5mm pilot holes through the block of wood for each of the four mounting screws provided with the servo.

* Using the thread as a guide and using masking tape, tape the servo lead to the end of the thread: carefully pull the thread out. When you have pulled the servo lead out, remove the masking tape and the servo lead from the thread.

* Place the servo into the servo tray/ hatch into the servo box on the bottom of the wing and drill 1.5mm pilot holes through the tray and servo box for each of the four mounting screws. Secure the servo tray in place using the mounting screws provided.

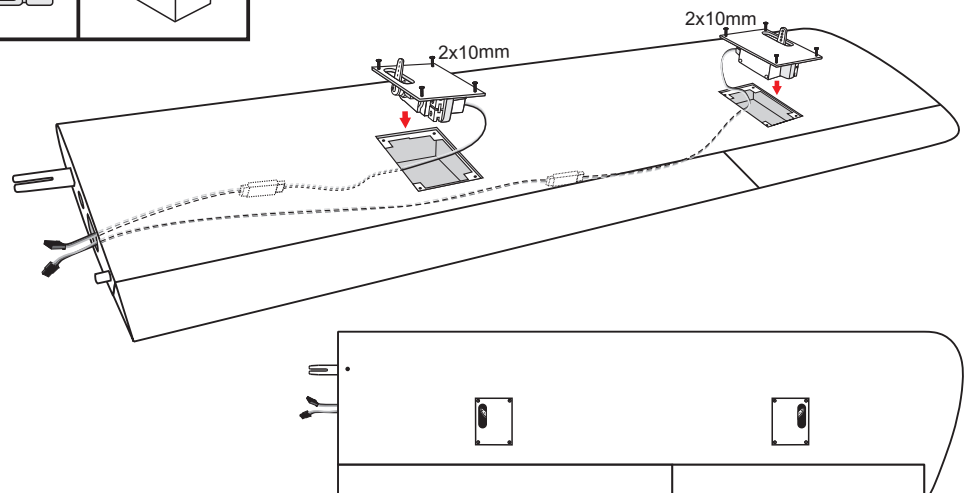
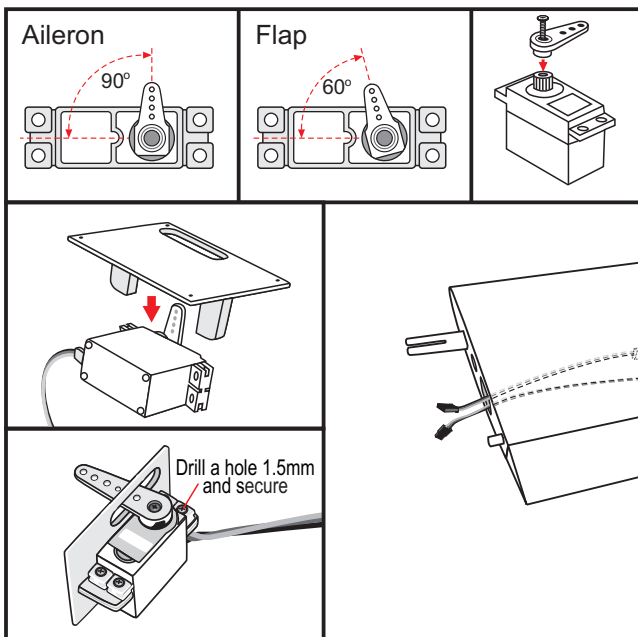

3. INSTALLING THE CONTROL HORNS, LINKAGES

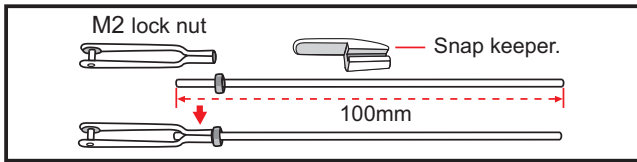

Insert the 90 degree bend down through the hole in the control horn. Install one nylon snap keeper over the wire to secure it to the control horn. Install the control horn retaining screw and remove the masking tape from the aileron.

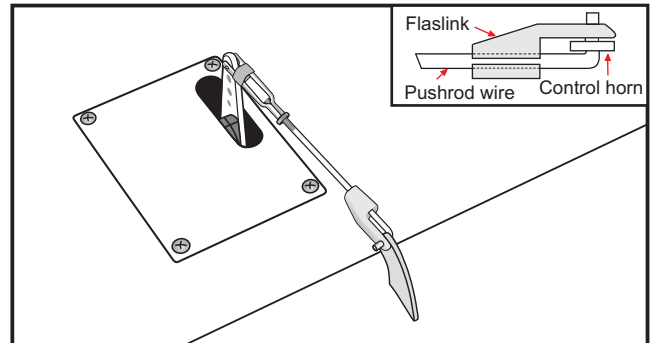
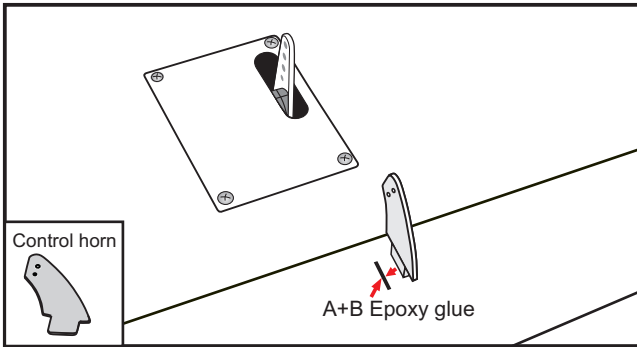

- * Attach the clevis to the outer hole in the servo arm. Install a silicone tube on the clevis.
- * Using pliers, carefully make a 90 degree bend down at the mark made. Cut off the excess wire, leaving about 6mm beyond the bend.

After both linkages are completed. connect both of the aileron servo loads using a Y-harness you have purchased.

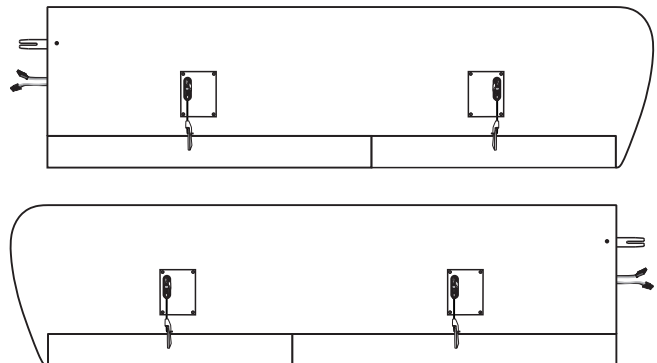
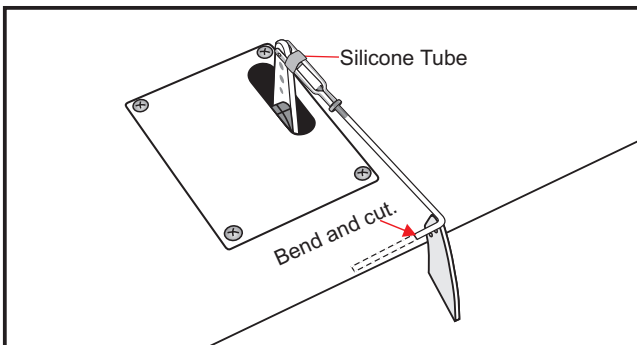

4. INSTALLING THE ENGINE MOUNT

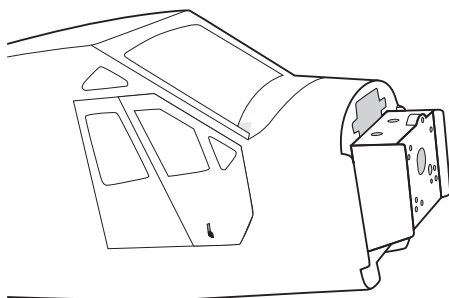

- There are two options:
1. Electric motor
 2. Engine mount.

OPTION 1: ELECTRIC MOTOR

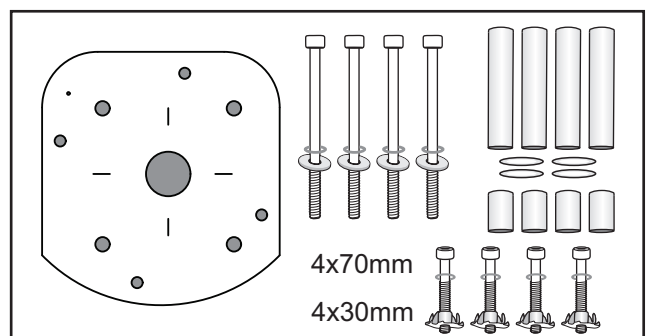

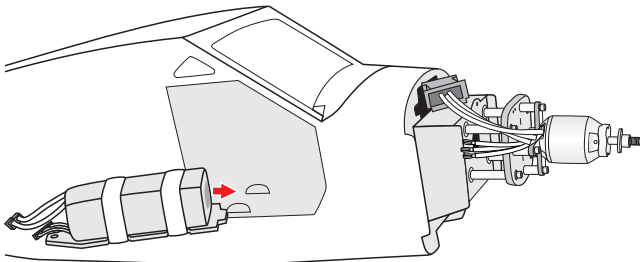
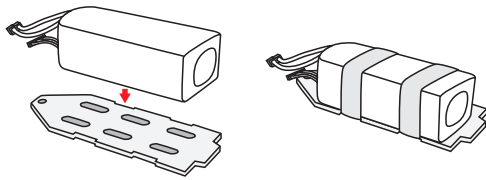
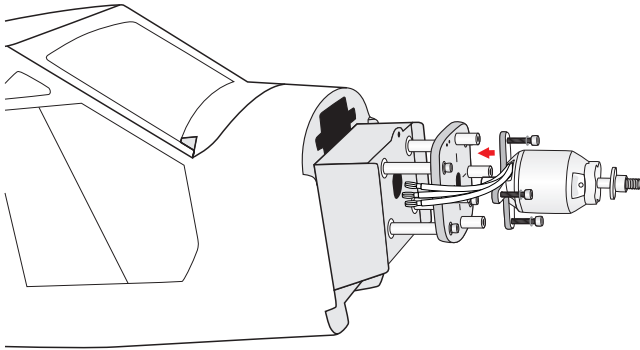

OPTION 2: ENGINE MOUNT, FUEL TANK

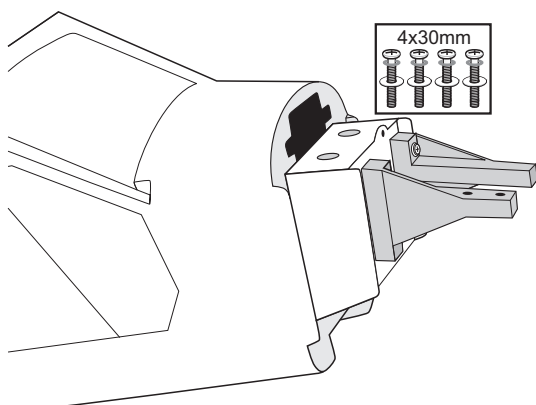
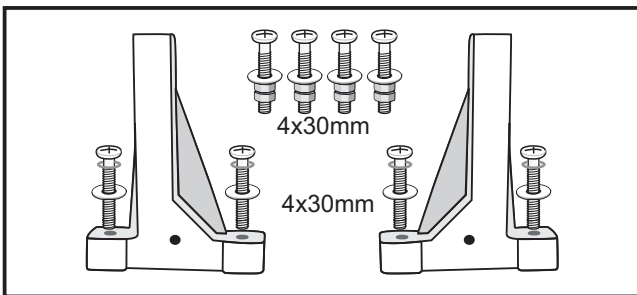

INSTALLING THE STOPPER ASSEMBLY

- 1) The stopper has been pre-assembled at the factory.
- 2) Using a modeling knife, cut one length of silicon fuel line (the length of silicon fuel line is calculated by how the weighted clunk should rest about 8mm away from the rear of the tank and move freely inside the tank). Connect one end of the line to the weighted clunk and the other end to the nylon pick up tube in the stopper.
- 3) Carefully bend the second nylon tube up at a 45 degree angle (using a cigarette lighter). This tube will be the vent tube to the muffler.
- 4) Carefully bend the third nylon tube down at a 45 degree angle (using a cigarette lighter). This tube will be vent tube to the fueling valve.

When the stopper assembly is installed in the tank, the top of the vent tube should rest just below the top surface of the tank. It should not touch the top of the tank.

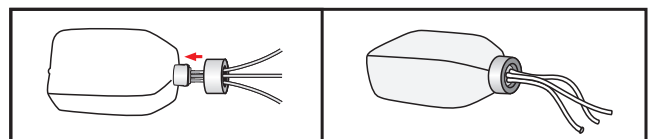
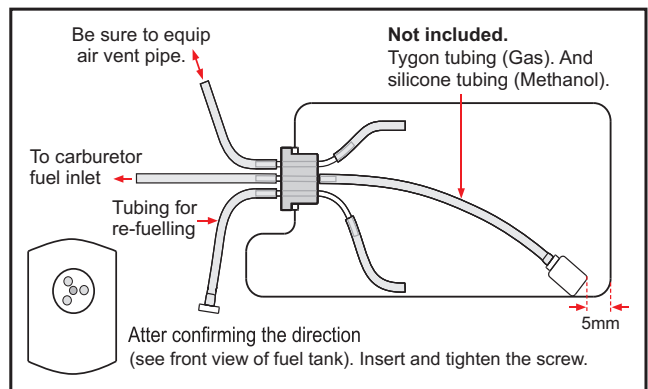
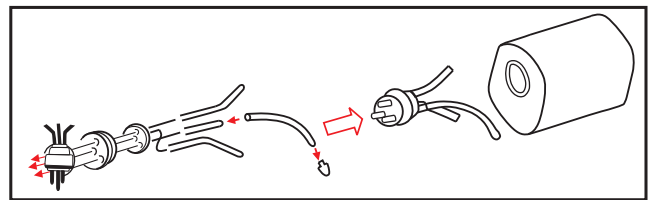

- 5) Test fit the stopper assembly into the tank. It may be necessary to remove some of the flashing around the tank opening using a modeling knife. If flashing is present, make sure none of it falls into the tank.
- 6) When satisfied with the alignment of the stopper assembly tighten the 3mm x 20mm machine screw until the rubber stopper expands and seals the tank opening. Do not over tighten the assembly as this could cause the tank to split.

7) Using a modeling knife, cut 3 lengths of fuel line 150mm long. Connect 2 lines to the 2 vent tubes and 1 line to the fuel pickup tube in the stopper.

8) Feed three lines through the fuel tank compartment and through the pre-drilled hole in the firewall. Pull the lines out from behind the engine, while guiding the fuel tank into place. Push the fuel tank as far forward as possible, the front of the tank should just about touch the back of the firewall.

Blow through one of the lines to ensure the fuel lines have not become kinked inside the fuel tank compartment. Air should flow through easily.

9) To secure the fuel tank in place, apply a bead of silicon sealer to the forward area of the tank, where it exits the fuselage behind the engine mounting box and to the rear of the tank at the forward bulkhead.

Do not secure the tank into place permanently until after balancing the airplane. You may need to remove the tank to mount the battery in the fuel tank compartment.

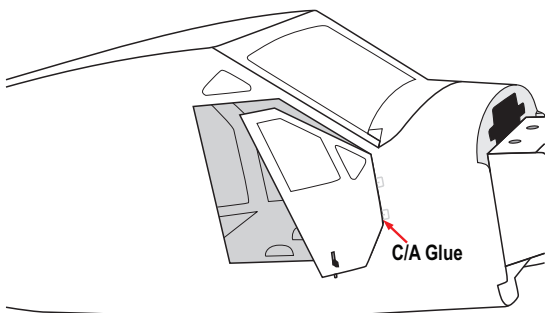
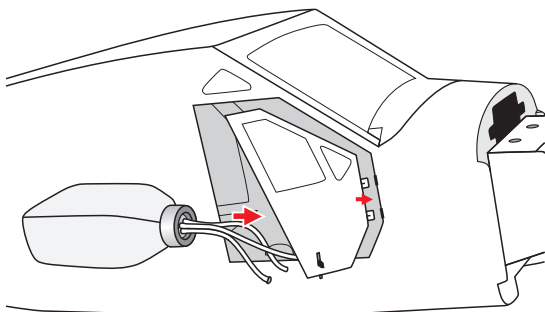

INSTALLING THE THROTTLE PUSHROD

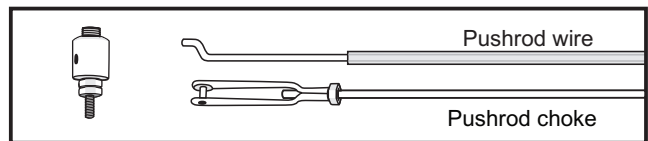

* Locate the long piece of wire used for the throttle pushrod. One end of the wire has been pre-bend in to a "Z" bend at the factory. This "Z" bend should be inserted into the throttle arm of the engine when the engine is fitted onto the engine mount. Fit the engine to the engine mount using the screws provided.

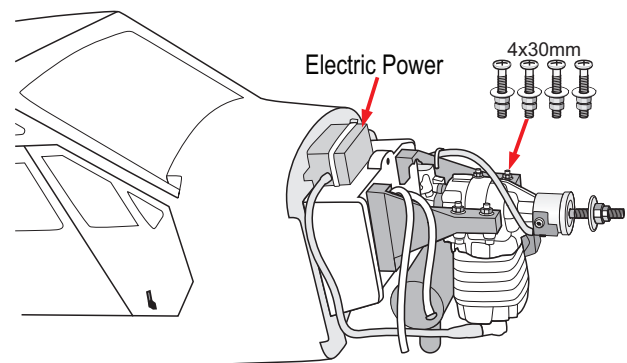
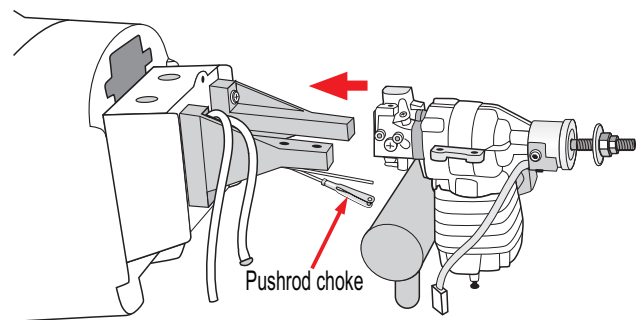

5. INSTALLING THE FUSELAGE SERVOS

1) Install the rubber grommets and brass collets into the elevator, rudder and throttle servos. Test fit the servos into the servo tray. Trim the tray if necessary to fit your servos.

2) Mount the servo to the tray using the mounting screws provided with your radio system.

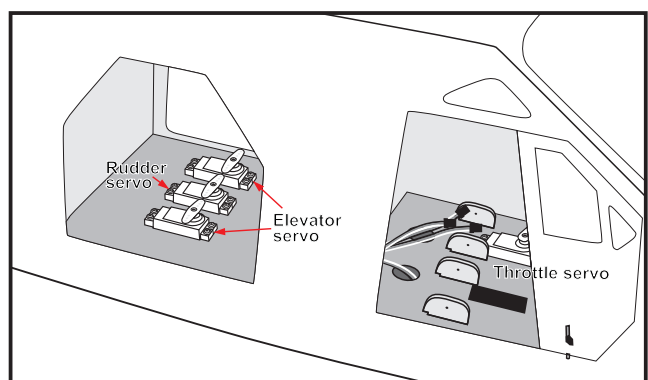

* Install one adjustable metal connector through the third hole out from the center of one servo arm, enlarge the hole in the servo arm using a 2mm drill bit to accommodate the servo connector. Remove the excess material from the arm.

After installing the adjustable metal connector apply a small drop of thin C/A to the bottom nut. This will prevent the connector from loosening during flight.

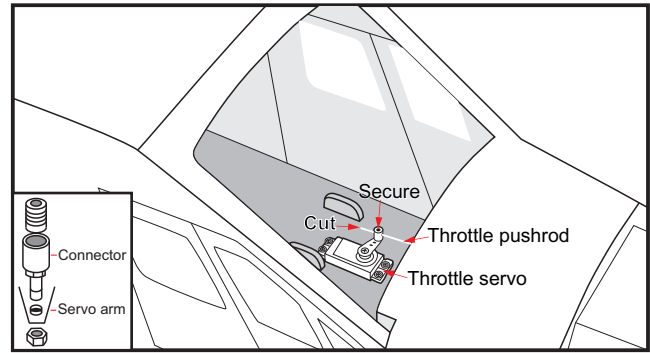

6. COWLING

1) Slide the fiberglass cowl over the engine and line up the back edge of the cowl with the marks you made on the fuselage.

2) While keeping the back edge of the cowl flush with the marks, align the front of the cowl with the crankshaft of the engine. The front of the cowl should be positioned so the crankshaft is in **nearly** the middle of the cowl opening. Hold the cowl firmly in place using pieces of masking tape.

3) Slide the cowl back over the engine and secure it in place using four wood screws. See picture below.

4) Install the muffler and muffler extension onto the engine and make the cutout in the cowl for muffler clearance. Connect the fuel and pressure lines to the carburetor, muffler and fuel filler valve.

Drill four 2.5mm pilot holes through both the cowl and the side edges of the firewall. Using a 3mm drill bit, enlarge the four holes in the cowling.

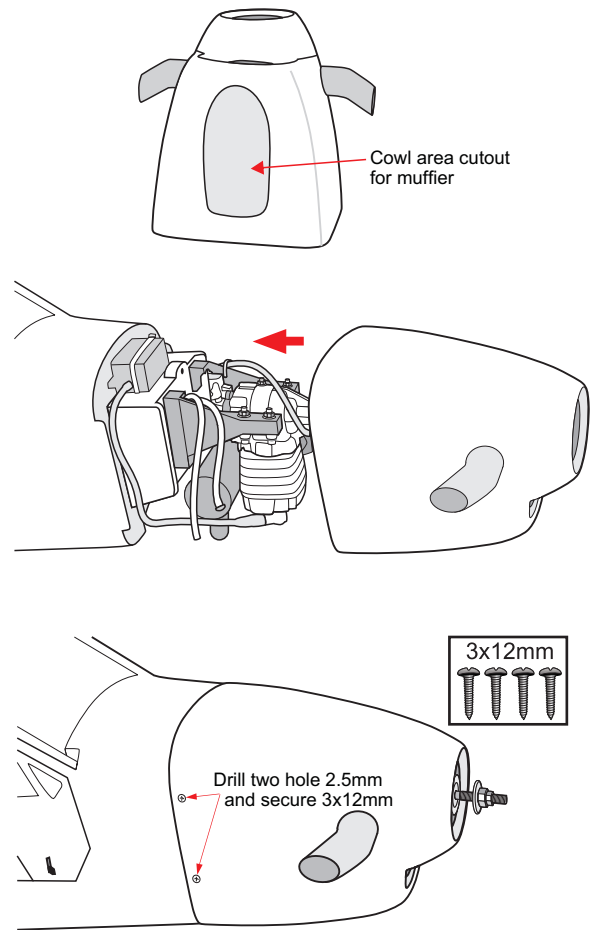

7. INSTALLING MAIN GEAR

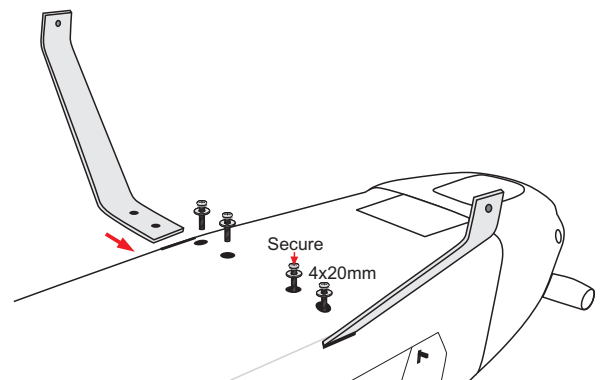
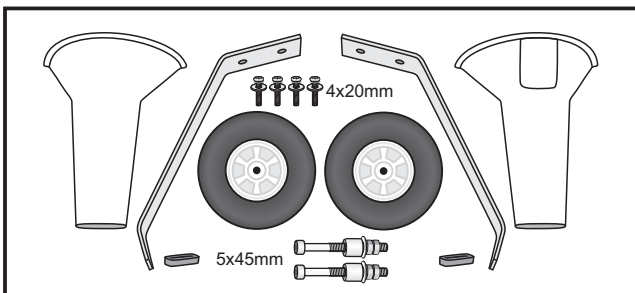

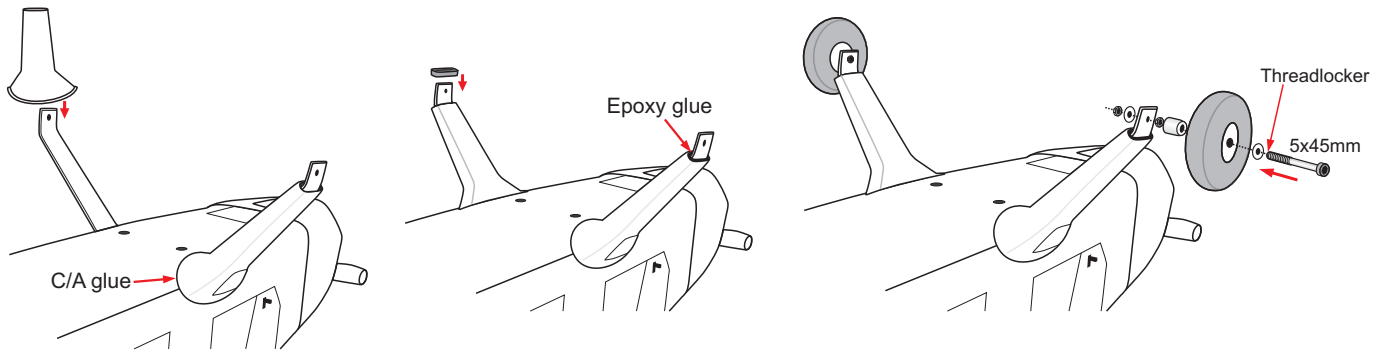

8. INSTALLING HORIZONTAL STABILIZER

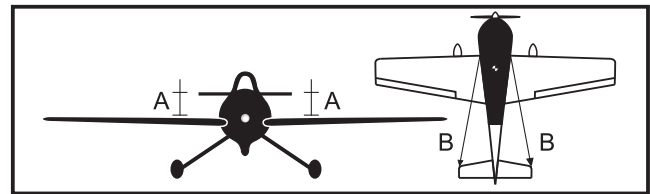
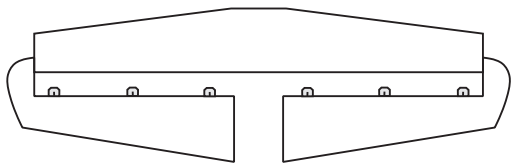

1) Using a modeling knife, carefully remove the film covering from the tail slots at the rear of the fuselage. Make sure that you do not remove any wood from the slots as this will affect the alignment of the tail.

Check to mark sure the wing and stabilizer are parallell. If they are not, lightly sand the opening in the fuselage for the stabilizer until the stabilizer is parallell to the wing, but don't glue anything yet.

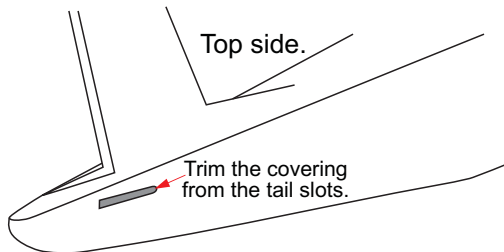

2) Draw a center line onto the horizontal stabilizer. Then put the horizontal into the fuselage.

5) With the horizontal stabilizer correctly aligned. Apply a thin CA layer to the top and bottom of the stabilizer in the fuselage.

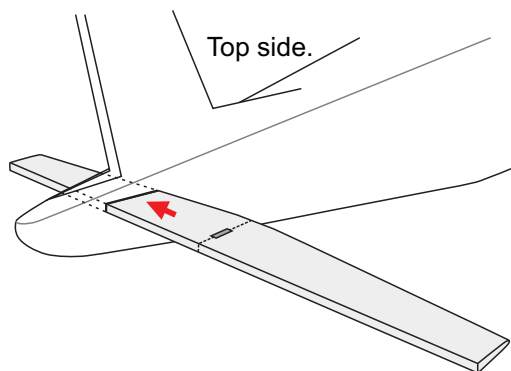
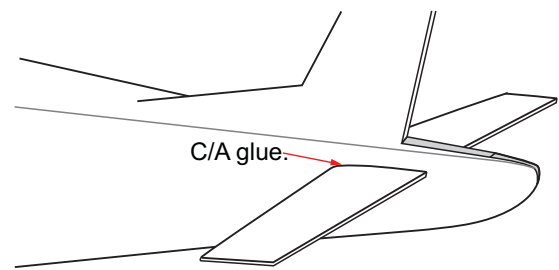
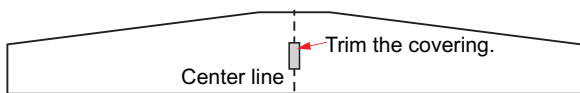

3) Check the fit of the horizontal stabilizer in its slot. Make sure the horizontal stabilizer is square and centered to the fuselage by taking measurements, but don't glue anything yet.

6) Hinges for Elevator are glued the same way as the aileron before (see page 4).

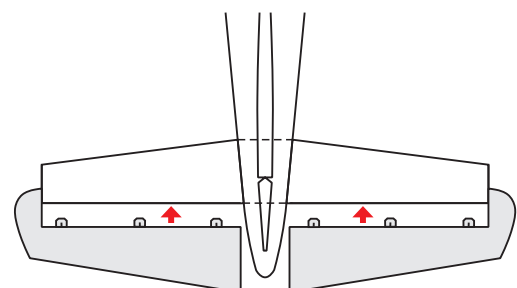

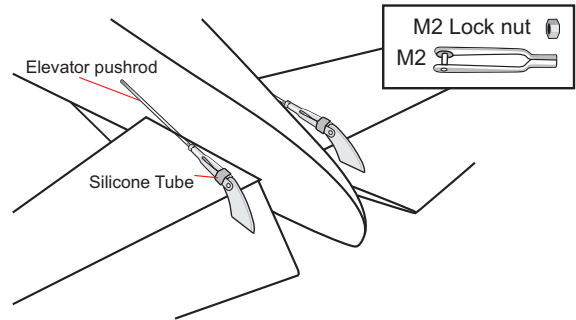
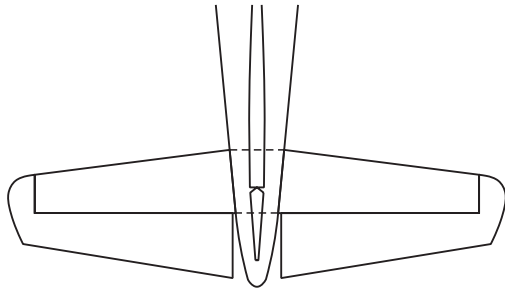

8.1. ELEVATOR CONTROL HORN INSTALLATION

Control horn and linkages for Elevator are installed the same way as the ailerons before (see page 5).

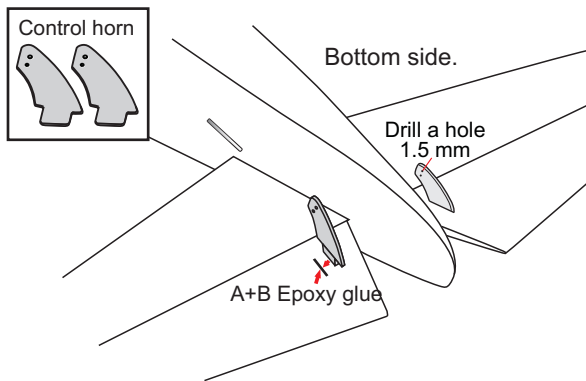

- 1) Using pliers, carefully make a 90 degree bend down at the mark made. Cut off the excess wire, leaving about 6mm beyond the bend.
- 2) Insert the 90 degree bend down through the hole in the servo arm. Install one nylon snap keeper over the wire to secure it to the arm. Install the servo arm retaining screw.

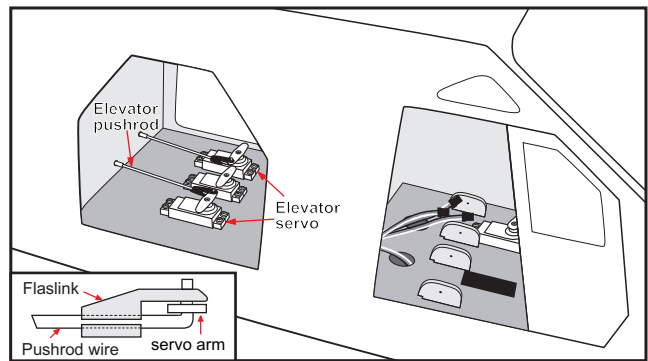

8.2. ELEVATOR PUSHROD INSTALLATION

9. THE TAIL WHEEL BRACKET, RUDDER INSTALLATION

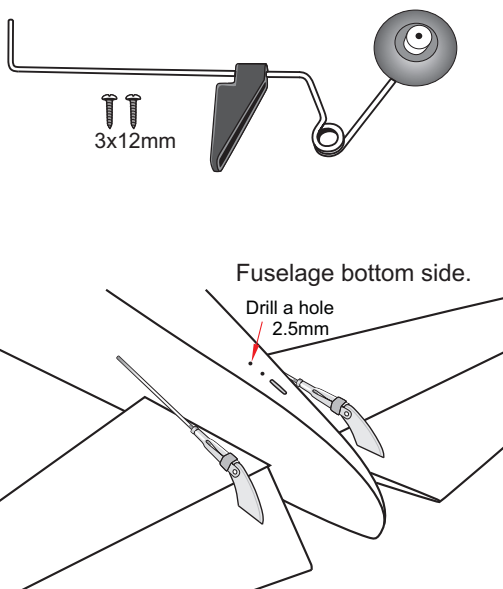

Secure the tail wheel bracket in place using 3mmx12mm wood screws. Be careful not to overtighten the screws.

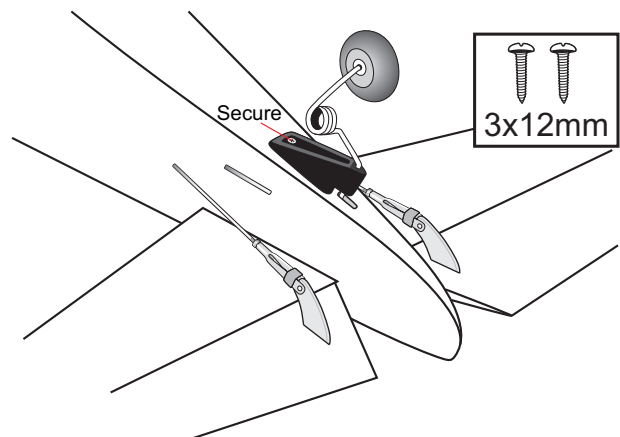

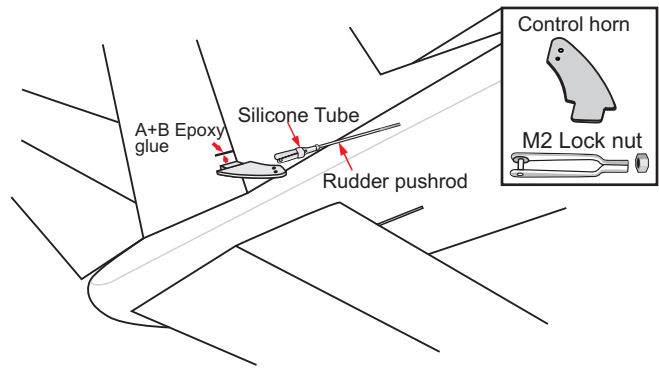
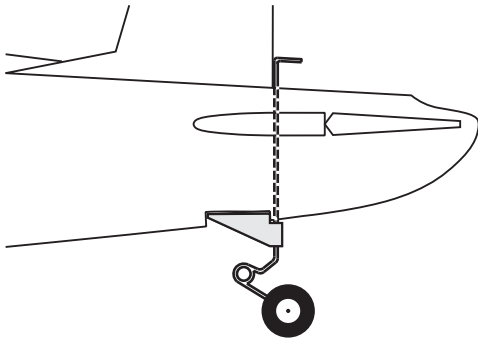

Hinges for Rudder are glued the same way as the aileron before (see page 4).

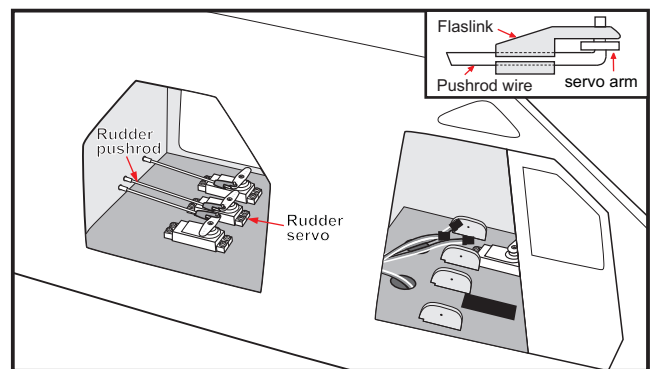
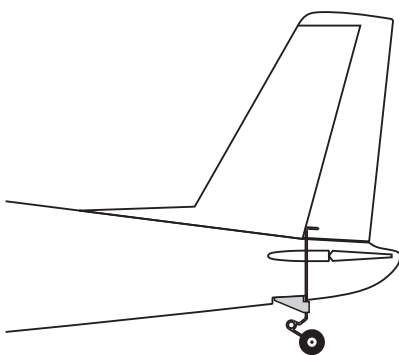
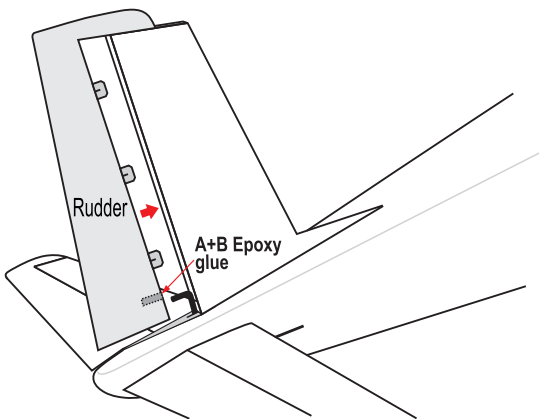

10. INSTALLING THE SWITCH, RECEIVER AND BATTERY.

1) Cut out the switch hole using a modeling knife. Use a 2mm drill bit and drill out the two mounting holes through the fuselage side.

2) Secure the switch in place using the two machine screws provided with the radio system.

3) Plug the servo leads and the switch lead into the receiver. You may want to plug an aileron extension into the receiver to make plugging in the aileron servo lead easier when you are installing the wing. Plug the battery pack lead into the switch.

4) Wrap the receiver and battery pack in the protective foam to protect them from vibration. Use a rubber band or masking tape to hold the foam in place.

5) Position the battery pack and receiver behind the fuel tank. Use two tie wraps to hold the battery and receiver securely in place as pictures below.

Do not permanently secure the receiver and battery until after balancing the model.

6) Using a 2mm drill bit, drill a hole through the side of the fuselage, near the receiver, for the antenna to exit.

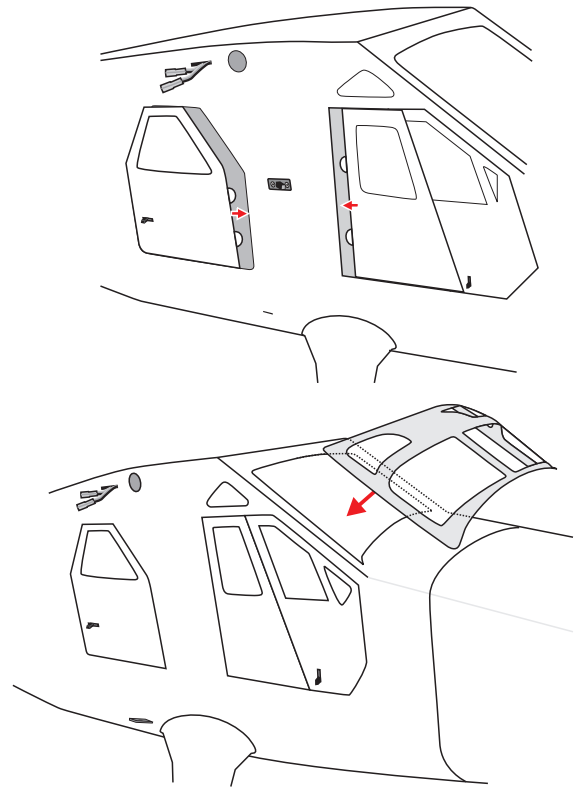
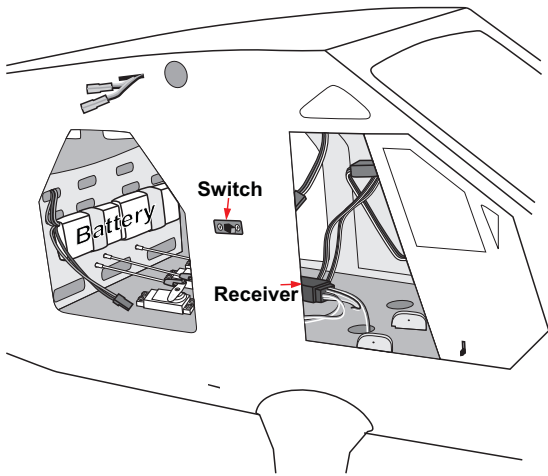

11. INSTALLING COCKPIT FUSELAGE

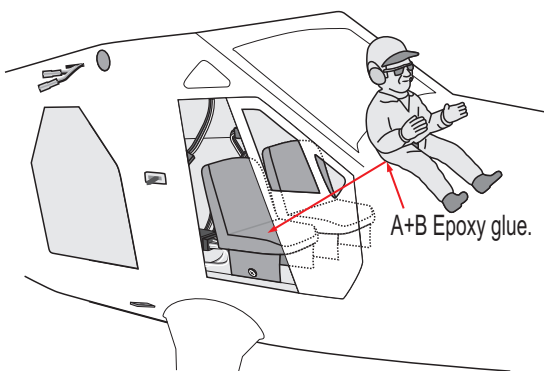
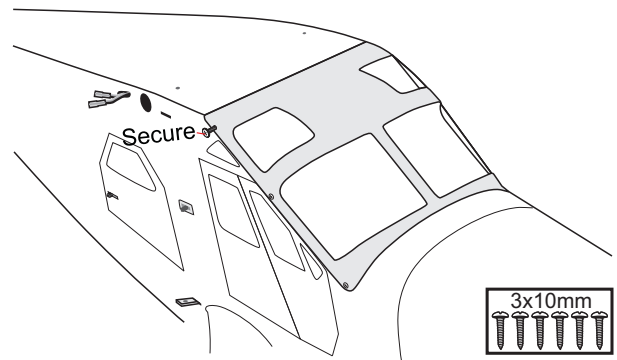
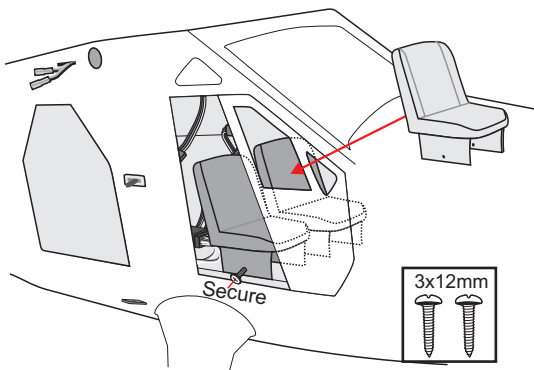
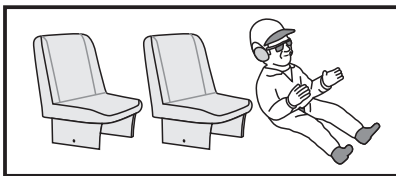

12. WING ATTACHMENT, WING STRUT

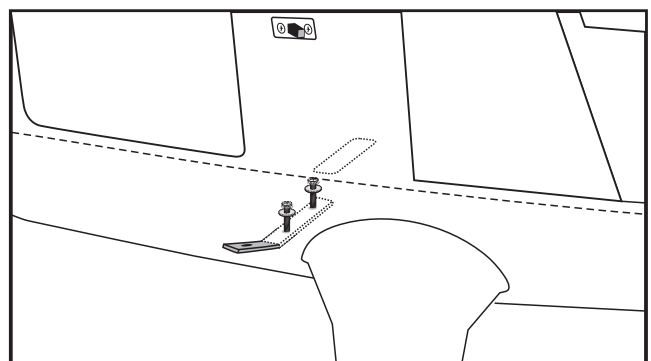
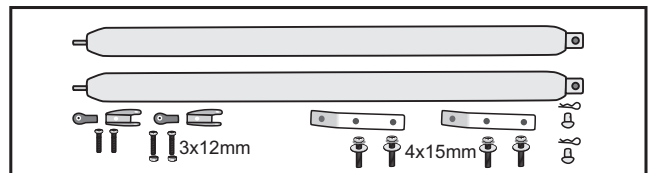

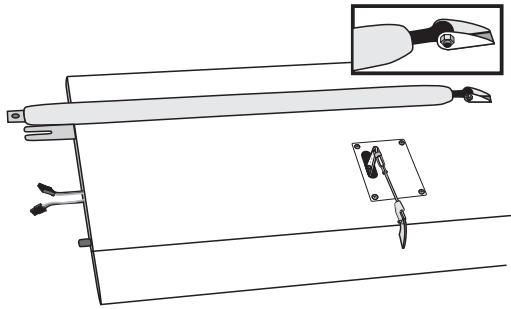

Locate the aluminium wing dihedral brace.

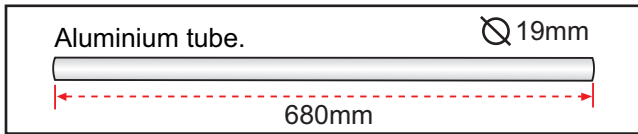

*** Test fit the aluminium tube dihedral brace into each wing haft. The brace should slide in easily. If not, use 220 grit sand around the edges and ends of the brace until it fits properly.

Attach the aluminium tube into the fuselage.

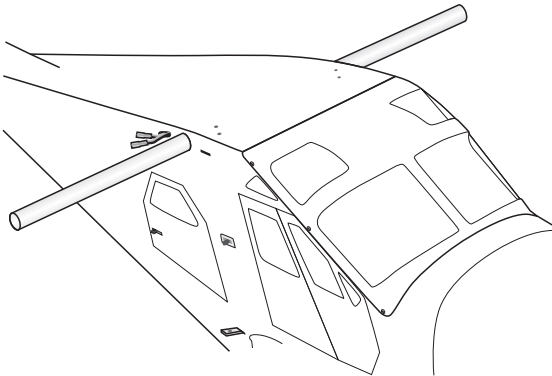

Insert the wing panel as pictures below.

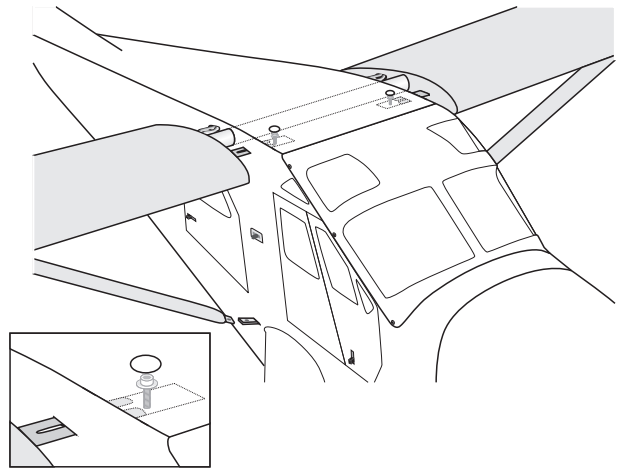

Screw the wing panel in position.

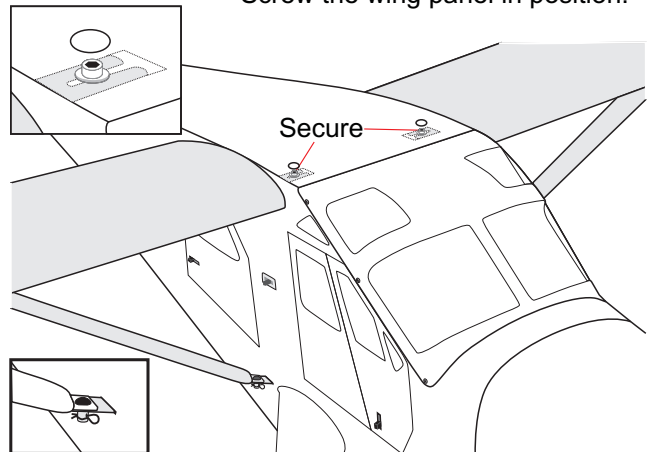

13. INSTALLING THE SPINNER

Install the spinner backplate, propeller and spinner cone. The spinner cone is held in place using two 3mm x 8 mm machine screws.

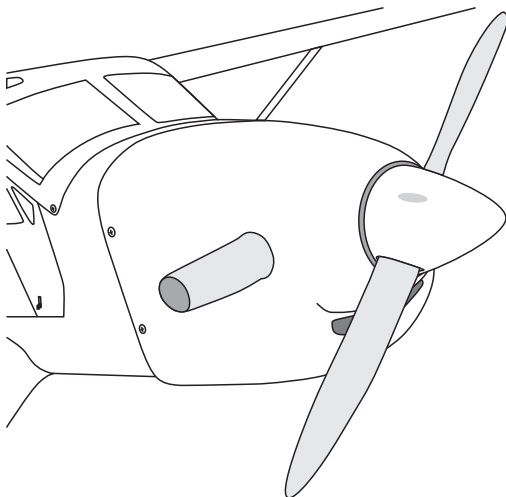

BALANCING

1) It is critical that your airplane be balanced correctly. Improper balance will cause your plane to lose control and crash.

THE CENTER OF GRAVITY IS LOCATED **73MM** BACK FROM THE LEADING EDGE OF THE WING.

2) Mount the wing to the fuselage. Using a couple of pieces of masking tape, place them on the top side of the wing **73mm** back from the leading edge, at the fuselage sides.

3) Turn the airplane upside down. Place your fingers on the masking tape and carefully lift the plane.

Accurately mark the balance point on the top of the wing on both sides of the fuselage. The balance point is located **73mm** back from the leading edge. This is the balance point at which your model should balance for your first flights. Later, you may wish to experiment by

shifting the balance up to 10mm forward or back to change the flying characteristics. Moving the balance forward may improve the smoothness and arrow-like tracking, but it may then require more speed for take off and make it more difficult to slow down for landing. Moving the balance aft makes the model more agile with a lighter and snappier "feel". In any case, please start at the location we recommend.

With the wing attached to the fuselage, all parts of the model installed (ready to fly), and empty fuel tanks, hold the model at the marked balance point with the stabilizer level.

Lift the model. If the tail drops when you lift, the model is "tail heavy" and you must add weigh* to the nose. If the nose drops, it is "nose heavy" and you must add weight* to the tail to balance.

*If possible, first attempt to balance the model by changing the position of the receiver battery and receiver. If you are unable to obtain good balance by doing so, then it will be necessary to add weight to the nose or tail to achieve the proper balance point.

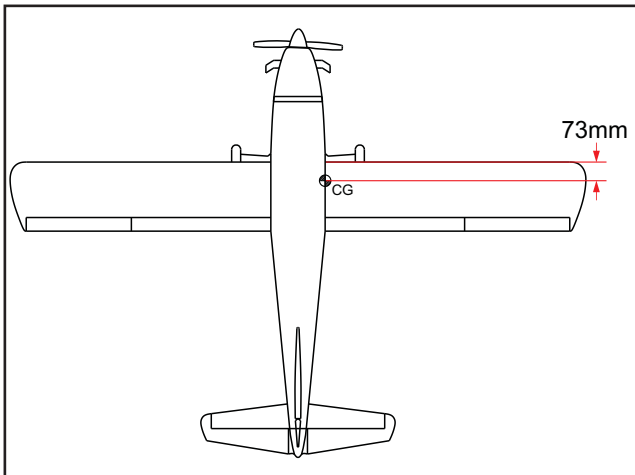

CONTROL THROWS

- 1) We highly recommend setting up a plane using the control throws listed.
- 2) The control throws should be measured at the widest point of each control surface.
- 3) Check to be sure the control surfaces move in the correct directions.

Control throw Ailerons:

Low: 10mm up / down.
High: 12mm up / down.

Control throw Flaps:

Mid: 20mm down.

Control throw Elevators:

Low: 10mm up / down.
High: 12mm up / down.

Control throw Rudder:

Low: 25mm left / right.
High: 30mm left / right.

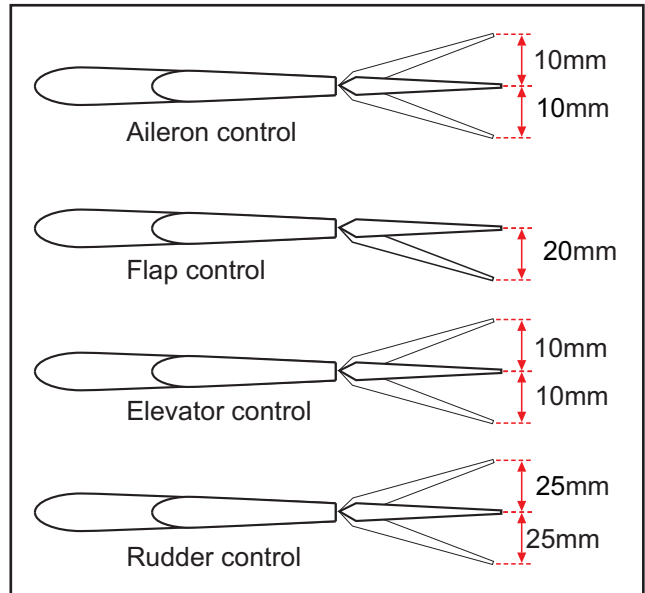

PRE-FLIGHT CHECK

- 1) Completely charge your transmitter and receiver batteries before your first day of flying.
- 2) Check every bolt and every glue joint in your plane to ensure that everything is tight and well bonded.
- 3) Double check the balance of the airplane.
- 4) Check the control surface.
- 5) Check the receiver antenna. It should be fully extended and not coiled up inside the fuselage. Check the receiver antenna. It should be fully extended and not coiled up inside the fuselage.
- 6) Properly balance the propeller.

We wish you many safe and enjoyable flights with your TURBO BEAVER.

I/C FLINGT WARNINGS

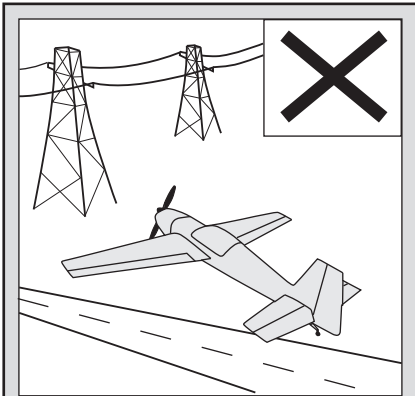

NEVER fly near power lines, aerials or other dangerous areas including airports, motorways etc.

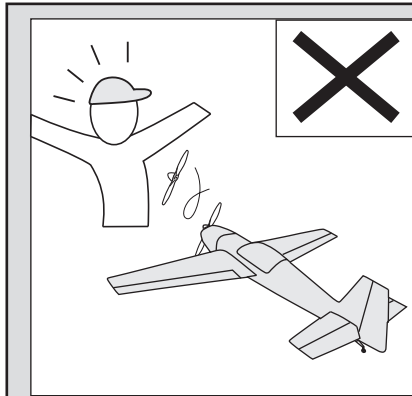

ALWAYS adjust the engine from behind the propeller, and do not allow any part of your body to be in line with the propeller.

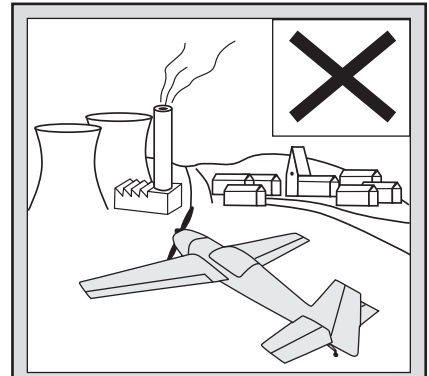

Always operate in open areas, away from factories, hospitals, schools, buildings and houses etc. **NEVER** fly your aircraft close to people or built up areas.

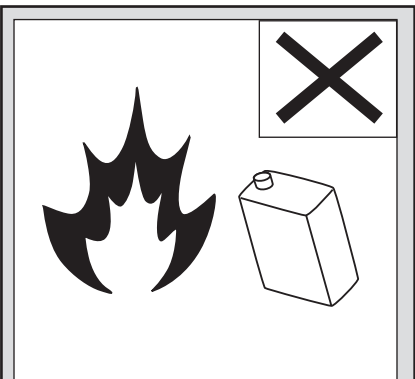

DO NOT dispose of empty fuel containers on a fire, this can lead to an explosion.

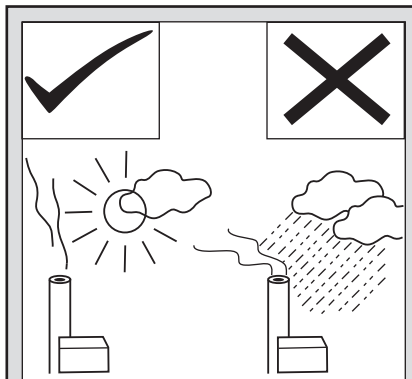

NEVER fly in wet conditions or on windy or stormy days.

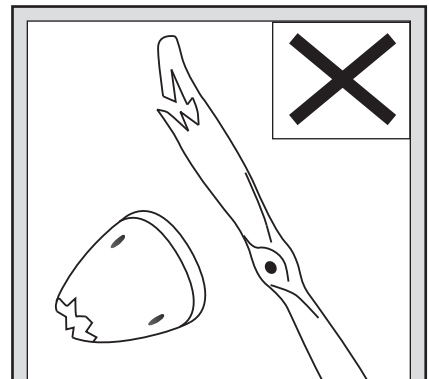

NEVER use damaged or deformed propellers or spinners.

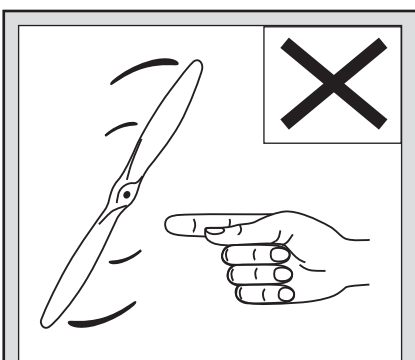

THE PROPELLER IS DANGEROUS.
Keep fingers, clothing (ties, shirt sleeves, scarves) or any other loose objects that could be caught or drawn in, away from the propeller. Take care at **ALL** times.

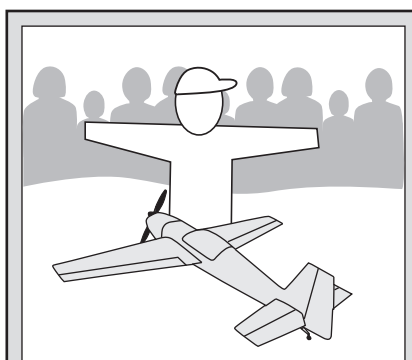

Keep all onlookers (especially small children and animals) well back from the area of operation. This is a flying aircraft, which will cause serious injury in case of impact with a person or animal.