

R7003SB

FASSTest-2.4GHz Bidirectional Communication System
S.BUS2 / S.BUS Port and Conventional System Receiver

INSTRUCTION MANUAL

Thank you for purchasing a Futaba R7003SB FASSTest-2.4GHz compatible receiver. The R7003SB receiver features bi-directional communication with a FASSTest Futaba transmitter using the S.BUS2 port. Using the S.BUS2 port an impressive array of **telemetry sensors** may be utilized. R7003SB has a merit which acquires the information from the model on flight by connecting an optional **telemetry sensors**. It also includes both standard PWM output ports and S.BUS output ports. 4 ports of R7003SB can choose an output channel from the 11 modes.

Usage precaution

- Analog servos cannot be used with the R7003SB in the FASSTest 12CH mode.
- The R7003SB receiver can only be used with FASSTest capable transmitters.

⚠ WARNING

- ⊘ Changes or modification not expressly approved by the party responsible for compliance could void the user's authority to operate the equipment.
- ⚠ The R7003SB receiver should be protected from vibration by foam rubber, Velcro or similar mounting methods. Protect from moisture.
- ⊘ Keep away from conductive materials to avoid short circuits.
- ⊘ Don't connect the servo or gyro which do not correspond to S.BUS2 port S.BUS2.
- When the servo and gyro which do not correspond to S.BUS2 are connected to S.BUS2 port, there is a danger of falling by malfunction.
- ⚠ Turn on the power in transmitter → receiver order. In addition, always check the operation of all the servos before flight.
- ⊘ Do not insert or remove the servo connector while the receiver power is ON.
- Since the S.BUS servo switches the operation mode automatically according to the type of signal (S.BUS signal/PWM signal) from the receiver, if the connector is inserted or removed while the power is ON, an S.BUS connected servo will be erroneously recognized and may stop.

Applicable systems: Futaba FASSTest-2.4GHz system-transmitter

If R7003SB does not use S.BUS/S.BUS2 system, it can perform only operation of 3 channels. However, if S.BUS/S.BUS2 system is used, use of the maximum channel of a transmitter can be performed. You have to use S.BUS/S.BUS2 servo, in order to use S.BUS/S.BUS2 system.

Antenna installation precaution

- ⊘ Do not cut or bundle the receiver antenna wire.
- ⊘ Do not bend the coaxial cable. It causes damage.
- ⊘ The antennas must be mounted in such a way to assure they are strain relieved.
- ⚠ Keep the antenna as far away from the motor, ESC and other noise sources as you possibly can.
- ⚠ Be sure that the two antennas are placed at 90 degrees to each other.
 - The R7003SB has two antennas. In order to maximize signal reception and promote safe modeling Futaba has adopted a diversity antenna system. This allows the receiver to obtain RF signals on both antennas and fly problem-free.

Antenna installation for carbon fuselage

⚠ WARNING

- ⚠ You must leave 30mm at the tip of the antenna fully exposed. The exposed antenna should be secured so that it cannot move around or back inside of your aircraft.

(Antenna installation)

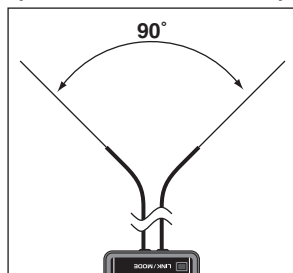

Please refer the table below for LED status vs receiver's condition.

LED Indication

Green	Red	Status
Off	Solid	No signal reception
Solid	Off	Receiving signals
Alternate blink		Unrecoverable error (EEPROM, etc.)

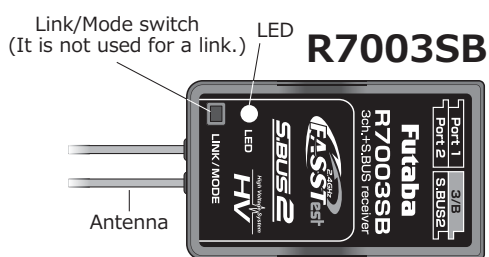

(Typical installation)

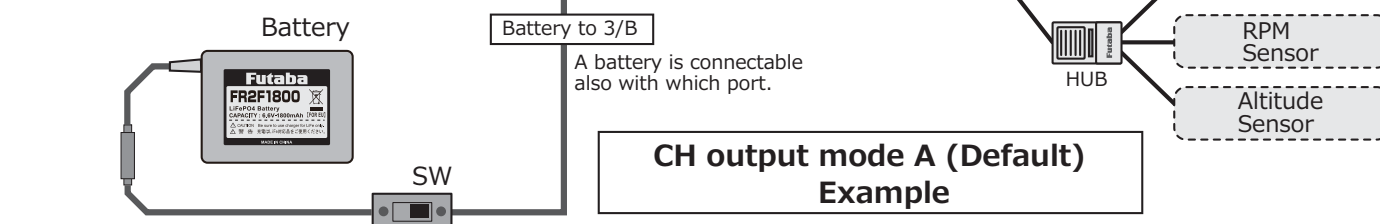

CH output mode A (Default) Example

Mode	Port			
	Port1	Port2	3/B	S.BUS2
A(Default)	S.BUS	CH2	CH3	S.BUS2

Compliance Information Statement (for U.S.A.)

This device, trade name Futaba Corporation of America, model number R7003SB, complies with part15 of the FCC Rules. Operation is subject to the following two conditions:

- (1) This device may not cause harmful interference, and
- (2) This device must accept any interference received, including interference that may cause undesired operation.
- (3) This module meets the requirements for a mobile device that may be used at separation distances of more than 20cm from human body.

To meet the RF exposure requirements of the FCC this device shall not be co-located with another transmitting device.

The responsible party of this device compliance is:

Futaba Service Center
3002 N Apollo Drive Suite 1, Champaign, IL 61822 U.S.A.
TEL (217)398-8970 or E-mail: support@futaba-rc.com (Support)

FASSTest

FASSTest is a bidirectional communication system between the R7003SB receiver and FASSTest capable transmitters. Multiple optional telemetry sensors may be connected to the S.BUS2 on the receiver and that data is in turn displayed on the transmitter.

*Please see your transmitters operation manual to configure transmitter to operate with telemetry sensors.

R7003SB Specifications

FASSTest-2.4GHz system/S.BUS2 and S.BUS port and conventional system receiver

- Dual antenna diversity
- Size: 0.89 x 1.47 x 0.37 in. (22.5 x 37.4 x 9.3 mm)
- Weight: 0.25 oz. (7.2g)
- Power requirement: 3.7V to 7.4V(Voltage range: 3.5 to 8.4V)
- Battery F/S Voltage: It sets up with a transmitter
- Extra Voltage port (port2)"EXT-VOL cable and CA-RVIN-700" of an option is used: 0 ~ 70V DC

* Be sure that when using ESCs regulated output the capacity of the ESC must meet your usage condition.

S.BUS2

S.BUS2 extends S.BUS and supports bidirectional communication. Sensors are connected to the S.BUS2 port.

Port	S.BUS Servo S.BUS Gyro	S.BUS2 Servo S.BUS2 Gyro	Telemetry sensor
S.BUS	○	○	×
S.BUS2	×	○	○

*Only S.BUS2 capable devices may be connected to the S.BUS2 port. Standard S.BUS servos and gyros should not be connected to the S.BUS2 port.

Link to the transmitter

Easy Link ID allows FASSTest receivers to link to compatible transmitter without pressing the link button on the receiver.

- 1 Bring the transmitter and the receiver close to each other, within 20 inches (half meter).
- 2 Turn on the transmitter. Place the transmitter into the receiver linking mode.
- 3 Turn on the receiver.
- 4 When the LED of the receiver changes from blinking red to solid green, linking is complete.

* Refer to the transmitters operation manual for complete details on how to place the transmitter into the linking mode.

* If there are many FASSTest systems turned on in close proximity, your receiver might have difficulty establishing a link to your transmitter. This is a rare occurrence. However, should another FASSTest transmitter/receiver be linking at the same time, your receiver could link to the wrong transmitter. This is very dangerous if you do not notice this situation. In order to avoid the problem, we strongly recommend you to double check whether your receiver is really under control by your transmitter.

* If the System Type of the transmitter is changed, the receiver will need to be re-linked to the transmitter.

* Link is required when a new model is made from a model selection.

⚠ WARNING

- ⊘ Do not perform the linking procedure while the motor's main wire connected or the engine is operating as it may result in serious injury.
- ⚠ When the linking is complete, please cycle the receiver power and ensure the receiver is properly linked to the transmitter.
- ⚠ Please power up your system in this order. Transmitter first, followed by the receiver.
- ⚠ If the R7003SB receiver was previously linked to another transmitter, make sure that transmitter is not operating while linking the receiver to the new transmitter.

Channel Modes

The R7003SB is capable of changing its channel allocations as described in the table below. Please choose the mode which suited the use in the following procedure from the 11 modes.

- 1 Press and hold down the Link/Mode button on the R7003SB receiver. [Transmitter is always OFF]
- 2 Turn the receiver on while holding down the Link/Mode button. After power up, the button can be released.
- 3 The LED should now be blinking red with green.
- 4 Each press of the Mode/Link button advances the receiver to the next mode. [Refer to CH Mode table shown below.]
- 5 When you reach the mode that you wish to operate in, press and hold the Mode/Link button for more than 2 seconds.
- 6 When LED blinks in green with red, it is the completion of a mode change.
- 7 Please cycle the receiver power off and back on again after changing the Channel Mode.

*5 seconds after the receiver ON, LED shows CH Mode.

R7003SB CH Mode table

Mode	Port				LED blink
	Port1	Port2	3/B	S.BUS2	
A(Default)	S.BUS			S.BUS2	Red 1 time
B	S.BUS2				Red 2 time
C	S.BUS	CH2		S.BUS	Red 3 time
D					Red 4 time
E	CH1				Green 1 time
F		CH4	CH3		Green 2 time
G	CH2				Green 3 time
H	CH1	CH5		S.BUS2	Green 4 time
I	CH2	CH7			Red and Green 1 time
J	CH4	CH8			Red and Green 2 time
K	CH11	CH12			Red and Green 3 time

Measurement of Extra Voltag

R7003SB can display the voltage of a receiver battery on a transmitter.

Furthermore, the following procedures are required in order to display the voltage of another battery (Drive battery etc.).

- 1 The optional adapter for CA-RVIN-700 is purchased.
- 2 R7003SB is changed into "EXT-VOL Mode" in the following procedure.
*If "EXT-VOL Mode" is used, the port 2 cannot be used as the servo CH.
- 3 According to the manual of CA-RVIN-700, battery wiring is branched and it connects.
- 4 One side of EXT-VOL CABLE is connected to the port 2 of R7003SB.

< How to change R7003SB into "EXT-VOL Mode" >

- 1 Turn on the receiver. LED lights up red. [Transmitter is always OFF]
- 2 Press and hold the Mode/Link button for 5 seconds to 10 seconds.
*It becomes the mode which makes a mistake in exceeding 10 seconds. In that case, carry out power supply OFF and redo.
- 3 The LED should now be early blinking green. Mode/Link button is released.
- 4 Each press of the Mode/Link button advances the receiver to the next mode.
- 5 When you reach the mode that you wish to operate in, press and hold the Mode/Link button for more than 2 seconds.
- 6 When LED blinks in green with red, it is the completion of a mode change.
- 7 Please cycle the receiver power off and back on again after changing the EXT-VOL Mode.

Mode	External voltage measurement	LED blink
Servo Mode(Default)	OFF	Green 1 time
EXT-VOL Mode	ON	Green 2 time

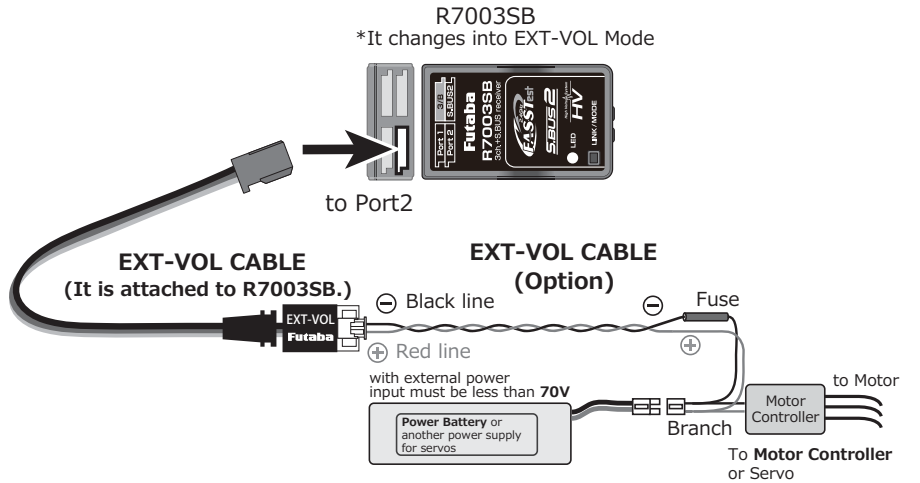

*It connects with reference to the manual of CA-RVIN-700.

⚠ WARNING

- ⊘ Don't touch wiring.
* There is a danger of receiving an electric shock.
- ⊘ Don't connect to Extra Voltage before turning on a receiver.
- ⚠ When not using EXT-VOL, "EXT-VOL Mode" is turned OFF.
- ⚠ Don't connect EXT-VOL CABLE other than port 2 of R7003SB.

When using the R7003SB Receiver with the GYA430, GYA431 and CGY750

The following table corresponds to the gyro's functions. A port can be used effectively. The servo which a gyro controls is connected to a gyro.

* Please refer to the description of each gyro manual.

S.BUS Gyro Goup table

Gyro control CH	CH Mode
Rudder	D,E
Elevator	F
Aileron	G
Elevator+Rudder	H
Aileron+Rudder	I
Aileron+Elevator	J
Aileron+Elevator+Rudder or CGY750	K

[Example: Connecting GYA431 to R7003SB CH Mode G]

(GYA431 is used for the aileron of an airplane)

