

Justock

USER MANUAL

Sensored Brushless Motor
Justock-3650-G2.1-Sensored

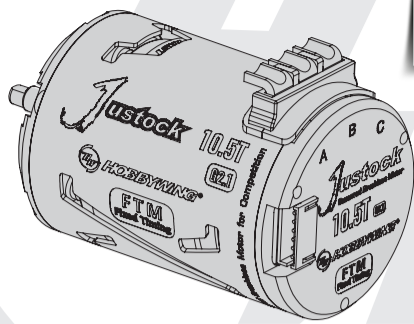

20180329



Thank you for purchasing the Justock 3650 G2.1 brushless motor(s) for RC cars! The high power system can be very dangerous, so please read this manual carefully before using and follow the operating procedures strictly. In that we have no control over the installation, use and maintenance of this product, no liability shall be assumed nor accepted for damages, losses or costs resulting from the use of this product. Besides, we own the right to change the product design, appearance, functions and operational requirements without any notifications.

01 Safety Notes



This product is NOT a toy and it is for use by adults and teens over 14 only, so please keep it out of children's reach. Please keep the following points in mind; otherwise it may damage the product and cause property loss and physical injuries to users.

- Never leave this product unsupervised when it is powered on. If any problem occurs, the product may cause a fire and jeopardize peripheral devices.
- Please check wire sequences between the ESC & the motor carefully before the connection, to avoid any possible mistakes.
- Please insure all the wires and interconnecting pieces are well insulated before the connection, as short circuits may damage the product.
- Never allow water, oil, fuel or other conducting liquids to get inside this product or other electronic parts, as these liquids may contain harmful minerals for electrical circuits. If that really happens, please turn off the device immediately, and then clear and blow-dry it carefully.
- Please read through manuals of each power equipment (like ESC, motor, battery, etc) and chassis to ensure the power system configuration is rational before the use, as the incorrect power system configuration may result in overload and eventually damage the equipments.
- Prohibit the full throttle operation before the pinion installation. Under non-loaded circumstances, over-high RPM may cause damage to the motor.
- Make sure all the parts are well connected, as misconnection or poor connection may lead to abnormal control, damage or other unpredictable problems.
- Never let the temperature of the motor can (shell) exceeds 90°C (194°F), otherwise the motor is likely to be damaged and (or) the rotor will be demagnetized.

02 Features

- The use of a heat-resistant magnet attached aluminum case and double insulated windings, high precision bearings, and rotor with a strong structure guarantees outstanding performance and super durability.
- The built-in Hall sensor non-adjustable end bell combined with a high precision and balanced rotor guarantees the user a smooth and linear power on demand.
- The silicon O-ring seal fitted between the end bell and stator helps to conduct inner heat to the motor case and prevent dust from entering the HALL sensor.
- The detachable structure design for daily cleaning and maintenance can effectively prolong the service life of this Justock motor and improve its operating efficiency.
- This motor is perfectly matched with the XR10-Justock ESC for all zero timing spec racing and also compatible with other Hobbywing Electronic Speed Controllers including other brands.
- This Justock motor is applicable to various 1/10th, 1/12th on-road & off-road vehicles. It can be an ideal choice for Stock or Sport class races but can also be a nice choice for newbies for practice.
- The motor design is in compliance with IFMAR, and ROAR specifications.

03 Specifications

PN	Model	KV (No-load)	LiPo	Resistance	No-load Current	Max. Output Power	C. at the point of M.O.P *	Dimension (mm)	Shaft * (mm)	Pole	Stock Rotor	Weight	Applications
3040809	Justock-3650-G2.1-10.5T	4000KV	2-3S	0.016 Ω	4.9A	275W	80A	Ø=35.9mm (1.413in)	Ø=3.17mm (0.125in)	2	Φ7-12.5	175g (6.17oz)	STOCK/SPORT class (choose the motor as per competition rules) of 1/10th, 1/12th On-road (i.e. competition touring car or drift, F1, Mini car, and etc.) and Off-road (i.e. buggy, 2WD SCT & truck) racing, Normal Training, and Rock Crawlers (21.5T & 25.5T only).
3040810	Justock-3650-G2.1-13.5T	3200KV		0.027 Ω	4A	215W	65A						
3040811	Justock-3650-G2.1-17.5T	2450KV		0.045 Ω	3.5A	157W	47A						
3040812	Justock-3650-G2.1-21.5T	2050KV		0.07 Ω	3A	115W	35A						
3040813	Justock-3650-G2.1-25.5T	1600KV		0.104 Ω	2.8A	86W	25A	L=52.5mm (2.067in)	L=15mm (0.591in)			Φ7-12.3-U	

Notes: C. at the point of M.O.P. = Current at the point the Maximum Output Power.

1) The maximum output power is the test value obtained when the voltage is 7.4V, the ESC timing is set to 0°. It is neither the maximum input power nor the rated power. The calculation formula used here is: RPM x Torque / 9550.

2) The value of the maximum output power is always lower than the value of the input power. Therefore, it's meaningless to compare the maximum output power mentioned in the form above with the input power of motors of other brands. Besides, values in the form above may differ from the test data of other factories because of different test benches.

3) The input current at the point of the maximum output power is useful for the load configuration and the ESC selection; here we strongly suggest users not make the load quota bigger than the "maximum output power point", that means please don't make the input current larger than the current at the maximum output power point.

4) As the power of these motors is not big, so they are not applicable for 4WD / Monster trucks and other high weight and heavy load vehicles or games need very great power. If forcibly use them in those conditions, perhaps they will get burnt. Hereby, we suggest users choose the 4-pole motor like Xerun-3660SD-G2 when high power is needed.

04 Installation & Connection

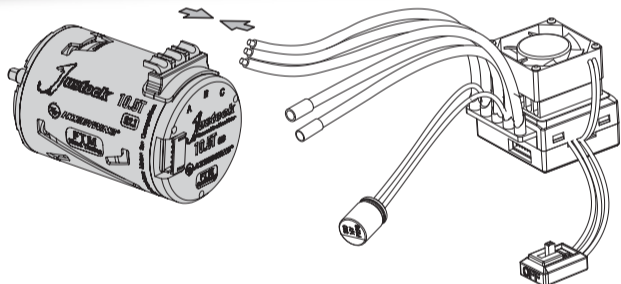

1. To Install the Motor

1) Screws used for installation are 3mm in diameter & 5mm in length. Before mounting the motor onto the vehicle, please ensure that all the screws are applicable to avoid damaging the motor. In general it's ok to adopt screws which are 3 mm in diameter and less than 8mm in length; the specific length is up to the chassis size.

2. To Connect the Motor

1) Three power wires need to be connected to the motor, and they often differ in colors: Phase wire A is Blue, Phase wire B is Yellow and Phase wire C is Orange. Please note the ESC mark while connecting ESC output wires to motor power wires and ensure connections are: A-A, B-B and C-C.

2) If you are using a sensored ESC, please insure Hall-sensor wires are clean and undamaged; then connect them in the correct direction to the sensor ports of the motor & the ESC respectively. Warning: In such a case, the wire sequence of the ESC and the motor must strictly follow the rules of A-A, B-B and C-C. Do not change the wires sequence.

3) While if the ESC is a sensorless one, then connect the motor and the ESC according to the above way may cause the motor to rotate in the opposite direction, because definitions of phase (#A / #B / #C) are different among manufacturers, at this time you only need to swap any of two wire connections.

3. Checkup

Recheck the installation and all the connections carefully before turning on the power.

05 Gear Selection

It is very important to select the reasonable gear ratio, as inappropriate selection may cause great loss to users. Please select the correct gear ratio according to the following points!

1. Operating Temperature of the Motor

During the operation, the motor temperature should be lower than 90°C (194°F). Temperatures above 90°C will demagnetize the magnet & may melt the coils and eventually damage the ESC (because of strong current). Therefore, the most effective way to prevent over-heat is to select the right gear ratio.

2. Principle of Gear Selection

To avoid potential risks, caused by overheating, which may lead to ESC/motor damage or malfunction, please start with very small pinion and check ESC & motor temperatures frequently throughout a run. This is the only way to guarantee that you are not causing excessive heating. If Motor and the ESC temperatures remain stable and low in the running, then you can slowly increase the pinion (with more teeth) while again monitoring the temperatures to determine the safe gearing for your vehicle and motor. Because the climate and track conditions always change, please keep monitoring ESC & motor temperatures to protect your electronics from damage.

3. Gear Ratio(s) Suggested

The below form shows some rough data about gear ratios (these recommended ratios are reference values when setting the ESC to the Zero Timing Mode). If you don't know how to set the suitable gear ratio, please begin with a big ratio (i.e. small pinion) and then adjust as required, or consult with on-site drivers who are using the same power unit for basic information.

Vehicle Type	Battery	10.5T	13.5T	17.5T	21.5T	25.5T
Touring Car (for Small track)	7.4V LiPo	5.5:1	4.7:1	4.0:1	3.5:1	3.2:1
Touring Car (for Big track)	7.4V LiPo	5.0:1	4.0:1	3.5:1	3.0:1	2.7:1
1/12th Touring Car	3.7V LiPo	42mm	51mm	66mm	66mm	66mm
2WD Buggy	7.4V LiPo	8.0:1	7.0:1	6.0:1	5.5:1	5.2:1
4WD Buggy	7.4V LiPo	8.0:1	7.0:1	6.0:1	5.5:1	5.2:1

06 Assembly and Disassembly

For prolonging the motor life and raising its efficiency, we recommend users to check the bearing, and clean the motor regularly, and the specific interval depends on the usage frequency and terrains. Please follow the assembly diagram below to assemble the motor, and disassemble in reverse order.

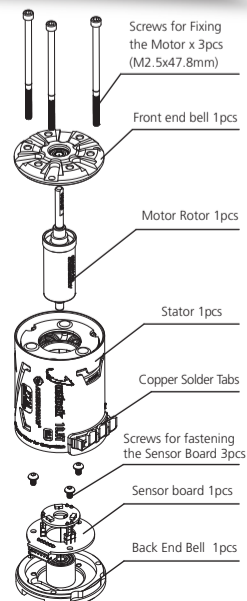
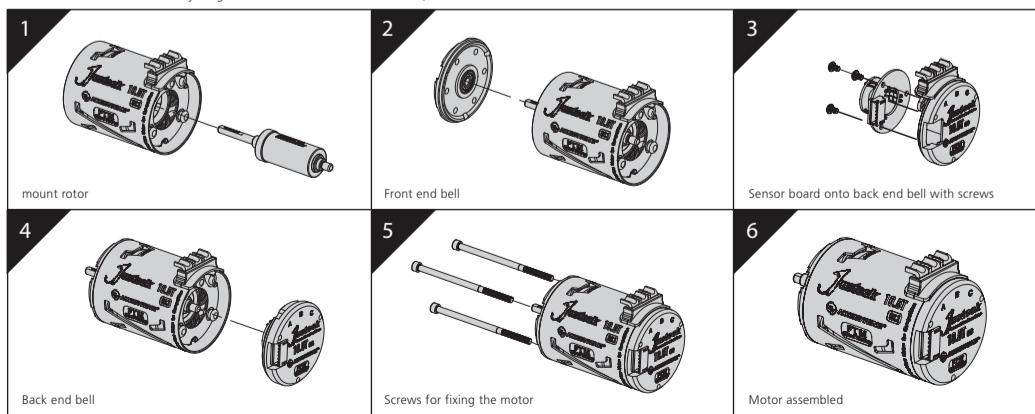

Optional Accessories

Replacement Part	Part No.	Product Name	Specifications
Bearing	30820001	540 MOTOR BEARING-3.175	R2ZZ bearing, 3.175 x 9.525 x 3.967mm
Motor Rotor	30820007	XERUN-V10 & Justock-G2-Rotor-Ø7-12.5	Thin magnet, w/o cooling fan, magnet hole Ø7, O.D. of the magnet:12.5mm
	30820014	XERUN-V10 & Justock-G2-Rotor-Ø7-12.3-U	Thin magnet / Strong Magnet, w/o cooling fan, magnet hole Ø7, O.D. of the magnet:12.3mm