

01 Introduction

EZRUN USER MANUAL

Brushless Electronic Speed Controller
EZRUN MINI28



Congratulations and thank you for your trust in Hobbywing product. By purchasing the EZRUN MINI28, you have chosen a high performance sensored brushless electronic speed controller! This speed controller is equipped with high-tech features to enhance your experience with Hobbywing brushless power systems. Improper usage and unauthorized modification to our product is extremely dangerous and may damage the product and related devices. Please take your time and read the following instructions carefully before you start using your speed control. We have the right to modify our product design, appearance, features and usage requirements without notification.

We, HOBBYWING, are only responsible for our product cost and nothing else as result of using our product.

02 Warnings

- To avoid short circuits, ensure that all wires and connections must be well insulated before connecting the ESC to related devices.
- Ensure all devices are well connected to prevent poor connections and avoid damage to your electronic devices.
- Read through the manuals of all power devices and chassis and ensure the power configuration is rational before using this unit.
- Please use a soldering iron with the power of at least 60W to solder all input / output wires and connectors.
- Stop immediate usage once the casing of the ESC exceeds 90°C / 194°F as this may cause damage to both the ESC and motor. Hobbywing recommends setting the "ESC Thermal Protection" to 105°C / 221°F (this refers to the internal temperature of the ESC).
- Users must always disconnect the batteries after use as the current on the ESC is consuming continuously if it is connected to the batteries (even if the ESC is turned off). The battery will completely be discharged and may result in damage to the battery or ESC when it is connected for a long period of time. This WILL NOT be covered under warranty.

03 Features

- The special program for 1/28 Mini racing, rich and exquisite adjustable parameters to meet the needs of different tracks and controls.
- The throttle driving frequency, brake frequency and initial throttle force are adjustable to realize the driver's accurate adjustment of the motor driving and braking.
- Multiple protection functions: low battery voltage protection, ESC overheat protection, fail-safe protection(theottle signal loss protection).
- Support LCD G2 program box and OTA programmer to set parameters of esc.
- Support the upgrade of esc firmware (LCD G2 program box or OTA programmer shall be purchased separately) and enjoy the latest functions.

04 Specifications

Model	EZRUN MINI28
Cont/Peak Current	30A / 80A
Motor Type	Sensored / Sensorless Brushless Motors
Applications	1 / 28 Mini
Motor Limit	1626 Size Motor
LiPo/NiMH Cells	2S Lipo
BEC Output	6V / 7.4V Adjustable, 3.5A Peak (Switch-mode)
Size	22.7 x 14.2 x 11.8mm
Weight	5g (without wires)
Programming Port	Shared with throttle cable

05 Connections

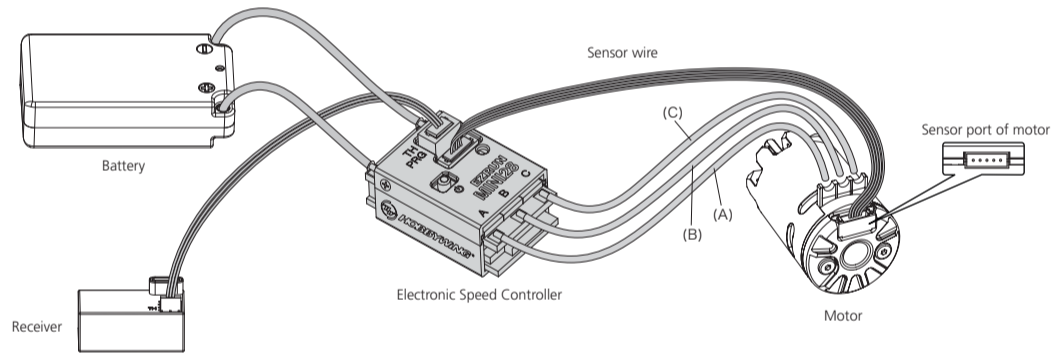

This is an extremely powerful brushless motor system. For your safety and the safety of those around you, we strongly recommend removing the pinion gear attached to the motor before performing calibration and programming functions with this system. It is also advisable to keep the wheels in the air when you turn on the ESC.

- Motor Wiring**
The motor wiring is different between the sensored and the sensorless; please only follow the introductions below.
 - Sensored Motor Wiring
There is strict wiring order from the ESC to the motor, the three A/B/C ESC wires must connect to the three A/B/C motor wires correspondingly. Next, connect the ESC sensor port and the motor sensor port with the stock 5-pin sensor cable. If you don't plug the sensor cable in, your ESC will still work in sensorless mode even if you're using a sensored motor.
 - Sensorless Motor Wiring
Users do not need to be worried in regards to the connectivity with the A/B/C(ESC and motor) as there is no polarity. You may find it necessary to swap two wires if the motor runs in reverse.
- Receiver Wiring**
The throttle control cable on the ESC has to be plugged into the throttle (TH) channel on the receiver. The throttle control cable has an output voltage of 6V / 7.4V to the receiver and steering servo, hence, no separate battery can be connected to the receiver. Otherwise, your ESC may be damaged.
- Battery Wiring**
Proper polarity is essential. Please ensure positive (+) connects to positive (+), and negative (-) connects to negative (-) when plugging in the battery! When reverse polarity is applied to the ESC from the battery, it WILL damage the ESC. This WILL NOT be covered under warranty!

06 ESC Setup

1 ESC/Radio Calibration

Begin using your ESC by calibrating with your transmitter. We strongly recommend Hobbywing users to use the "Fail Safe" function on the radio system and set (F/S) to "Output OFF" or "Neutral Position". Example of calibrating Neutral range and Endpoint.

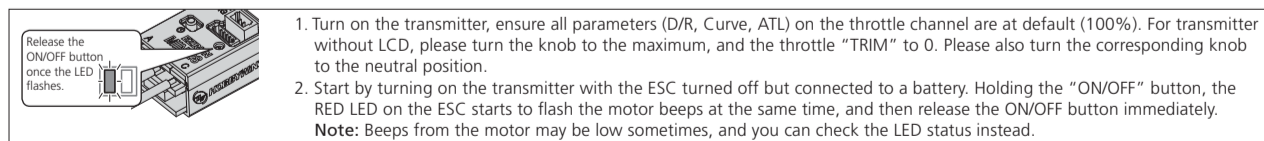

- Turn on the transmitter, ensure all parameters (D/R, Curve, ATL) on the throttle channel are at default (100%). For transmitter without LCD, please turn the knob to the maximum, and the throttle "TRIM" to 0. Please also turn the corresponding knob to the neutral position.
- Start by turning on the transmitter with the ESC turned off but connected to a battery. Holding the "ON/OFF" button, the RED LED on the ESC starts to flash the motor beeps at the same time, and then release the ON/OFF button immediately.
Note: Beeps from the motor may be low sometimes, and you can check the LED status instead.

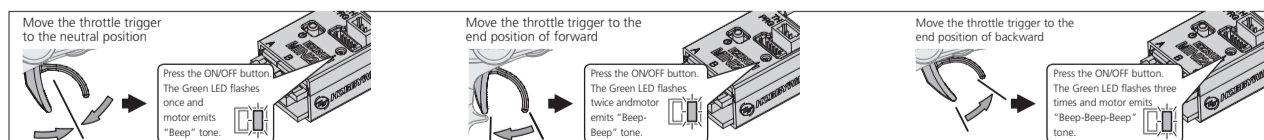

- Set the neutral point, the full throttle endpoint and the full brake endpoint.
 - Leave transmitter at the neutral position, press the "ON/OFF" button, the RED LED dies out and the GREEN LED flashes 1 time and the motor beeps 1 time to accept the neutral position.
 - Pull the throttle trigger to the full throttle position, press the "ON/OFF" button, the GREEN LED blinks 2 times and the motor beeps 2 times to accept the full throttle endpoint.
 - Push the throttle trigger to the full brake position, press the "ON/OFF" button, the GREEN LED blinks 3 times and the motor beeps 3 times to accept the full brake endpoint.
- Note:**
 - The end position of forward: Pull the trigger to the maxim um throttle position if it is pistol-style transmitter . Push the throttle to the top if it is board-style transmitter.
 - The end position of backward: Push the trigger to the maximum brake position if it is pistol-style transmitter. Pull the throttle to the bottom if it is board-style transmit ter.
- The motor can be started 3 seconds after the ESC/Radio calibration is complete.

2 Power On/Off

Short press ON/OFF button to power-on, long press on ON/OFF button to shut down.

Note: To prevent accidental shutdown, when the motor is running, it cannot be shut down by clicking the switch button, it can only be shut down when the motor stops running, when it cannot be shut down in case of emergency, please disconnect the battery directly.

3 Programmable Items

Section	Item	Programmable Items	Parameter Values													
General Setting	1A	Running Mode	Forward with Brake	Forward/ Reverse with Brake	Forward and Reverse											
	1B	Max. Forward Force			30%-100% Adjustable											
	1C	Max. Reverse Force	25%	50%	75%						100%					
	1D	Cutoff Voltage	Disabled	Auto (3.3V/Cell)												
	1E	ESC Thermal Protection	Disabled	105°C / 221°F	125°C / 257°F											
	1F	BEC Voltage	6.0V	7.4V												
	1G	Motor Rotation	CCW	CW												
Throttle Control	2A	Throttle Rate Control	1-30 Adjustable (Step: 1)													
	2B	Neutral Range	3%-10% Adjustable (Step: 1%)													
	2C	Initial Throttle Force	1%-15% Adjustable (Step: 1%)													
	2D	Coast	0%-15% Adjustable (Step: 1%)													
	2E	PWM Drive Frequency	1K	2K	4K	8K	12K	16K	24K	32K	Customized					
	2F	Softening Value	0-30° Adjustable (Step: 1°)													
Brake Control	2G	Softening Range	0%	10%	20%	25%	30%	35%	40%	45%	50%	55%	60%	65%	70%	75%
	3A	Drag Brake Force	0%-100% Adjustable (Step: 1%)													
	3B	Max. Brake Force	0%-100% Adjustable (Step: 1%)													
	3C	Brake Rate Control	1-20 Adjustable (Step: 1)													
	3D	Brake Frequency	1K	2K	3K	4K	6K	8K	12K	16K	Customized					
Timing	4A	Boost Timing	0-56° Adjustable (Step: 1°)													
	4B	Boost Timing Activation	RPM		Auto											
	4C	Boost Start RPM	500-3500RPM (Step: 500RPM)													
	4D	Boost End RPM	3000-6000RPM (Step: 500RPM)													
	5A	Turbo Timing	0-56° Adjustable (Step: 1°)													
	5B	Turbo Delay	Instant	0.02s	0.05s	0.1s	0.15s	0.2s	0.25s	0.3s	0.4s	0.5s	0.7s	1.0s		
	5C	Turbo Increase Rate	3deg/0.1s	6deg/0.1s	9deg/0.1s	12deg/0.1s	15deg/0.1s	18deg/0.1s	21deg/0.1s	24deg/0.1s	27deg/0.1s	30deg/0.1s	Instant			
5D	Turbo Decrease Rate	3deg/0.1s	6deg/0.1s	9deg/0.1s	12deg/0.1s	15deg/0.1s	18deg/0.1s	21deg/0.1s	24deg/0.1s	27deg/0.1s	30deg/0.1s	Instant				

1A. Running Mode

Option 1: Forward with Brake

Racing mode. It has only forward and brake functions.

Option 2: Forward/ Reverse with Brake

This option is known to be the "training" mode with "Forward/ Reverse with Brake" functions. Hobbywing has adopted the "DOUBLE-CLICK" method, that is your vehicle only brakes on the 1st time you push the throttle trigger forward (brake) (1st push). The motor stops when you release the throttle trigger and then re-push the trigger (2nd push), only then the vehicle will reverse. The reverse function will not work if your car does not come to a complete stop. The vehicle only reverses after the motor stops. This method is for preventing vehicle from being accidentally reversed.

Option 3: Forward and Reverse

This mode is often used by special vehicles (rock crawler). It adopts the "SINGLE-CLICK" method. The vehicle will reverse immediately when you push the throttle trigger forward (brake).

1B. Max.Forward Force

It refers to the force generated when the throttle trigger is at the maximum forward position. Different forward speeds can be generated by setting different values.

1C. Max. Reverse Force

The reverse force of the value will determine its speed. For the safety of your vehicle, we recommend using a low amount.

1D. Cutoff Voltage

Sets the voltage at which the ESC lowers or removes power to the motor in order to either keep the battery at a safe minimum voltage (for LiPo batteries). The ESC monitors the battery voltage all the time, it will immediately reduce the power to 50% (in 3 seconds) and cut off the output 40 seconds later when the voltage goes below the cutoff threshold. The RED LED will flash a short, single flash that repeats (☆, ☆, ☆) to indicate the low-voltage cutoff protection is activated. Please set the "Cutoff Voltage" to "Disabled" or customize this item if you are using NiMH batteries.

Option 1: Disabled

The ESC does not cut the power off due to low voltage. We do not recommend using this option when you use any LiPo battery as you will irreversibly damage the product. You need to select this option when you are using a NiMH pack.

Option 2: Auto

The ESC calculates the corresponding cutoff voltage for the battery shall be 6.6V.

Option 3: Customized

The customized cutoff threshold is a voltage for the whole battery pack (adjustable from 4.0V to 7.4V).

1E. ESC Thermal Protection

The output from the ESC will be cut off with the value you have preset.

The GREEN LED flashes (☆, ☆, ☆) when the ESC temperature reaches to the preset value. The output will not resume until the ESC temperature gets down.

Warning! Please do not disable this function unless you're in a competition. Otherwise the high temperature may damage your ESC and even your motor.

1F. BEC Voltage

BEC voltage can be adjusted by 6.0V/7.4V. 6.0V is applicable to common servo. If use high-voltage servo , set to higher voltage according to voltage marking of servo.

1G. Motor Rotation/Direction

With the motor shaft faces you (the rear end of the motor is away from you), increase the throttle input, the motor (shaft) will rotate in the CCW/CW direction if the "Motor Rotation / Direction" set to "CCW/CW".

Generally, the vehicle runs forward when the motor (shaft) rotates in the CCW direction. However, some vehicles only run forward when the motor rotates in the CW direction due to the different chassis design. In that case, you only need to set the "Motor Rotation/Direction" to "CW".

2A. Throttle Rate Control

This item is used to control the throttle response. It can be adjustable from 1 to 30 (step: 1), the lower the throttle rate, the more the limit will be on the throttle response. A suitable rate can help driver to control his vehicle properly during the starting-up process. Generally, you can set it to a high value to have a quick throttle response if you are proficient at throttle control.

2B. Neutral Range

As not all transmitters have the same stability at "neutral position", please adjust this parameter as per your preference. You can adjust to a bigger value when this happens.

2C. Initial Throttle Force

It also called as minimum throttle force. You can set it according to wheel tire and traction. If the ground is slippery, please set a small throttle force. Some motors have strong cogging effect with lower FDR number.

When you push throttle a little bit, the motor will not rotate until a higher throttle point than the default initial throttle point. When we have this parameter, we can use the transmitter trim to check the above issueand then adjust the best initial throttle point by increasing the ITF a little. The control feeling will be smoother if you find the best point. Normally the number will be not over 5%.

2D. Coast

The RPM of the motor will be lowered gradually when throttle is reduced. The vehicle will not reduce speed abruptly when the throttle is reduced to return to the neutral position. The bigger the value, the more the "COAST" will be felt. Example, COAST of 0 deactivates, and a COAST of 15% would be the maximum amount of COAST.

What is COAST?

When a vehicle has a larger final drive ratio, the tendency of having a "drag" feel is higher. The "COAST" technology is to allow the car to roll (coast) even when the final drive ratio is high. The Coast function brings better and smoother control feeling to racers. Some drivers will refer to this to the traditional brushed motors.

Note: The "Coast" will be void (even if you set it to any value besides 0) if the above "drag brake" is not "0%" .

2E. PWM Drive Frequency

The acceleration will be more aggressive at the initial stage when the drive frequency is low; a higher drive frequency is smoother but this will create more heat to the ESC. If set this item to "Customized", then the PWM frequency can be adjusted to a variable value (which ranges from 0K to 32K) at any 0-100% throttle input. Please choose the frequencies as per the actual test results of your vehicles.

2F. Softening Value

It allows users to fine-tune the bottom end, change the driving feel, and maximize the driving efficiency at different track conditions. The higher the "Softening Value", the milder the bottom-end. In Modified class, drivers often feel the power of the bottom end is too aggressive. Little throttle input usually brings too much power to the car and make it hard to control at the corners, so HOBBYWING creates this softening function to solve the issue.

Note: You can increase the motor mechanical timing accordingly after you set the softening value. Every time you increase the softening value by 5 degrees, you can increase the mechanical timing by 1 degree. For example, if you set the softening value to 20 degrees, then you can increase the mechanical timing by 4 degrees. Please note that you will never increase the mechanical timing by over 5 degrees.

2G. Softening Range

It's the range to which "Softening Value" starts and ends. For example, 0% to 30% will be generated when the user pre-programs the "Softening Range" at a value of 30%.

3A. Drag Brake

It is the braking power produced when releasing from full speed to neutral position. This is to simulate the slight braking effect of a neutral brushed motor while coasting. It's not recommended for buggy and monster truck.

(Attention! Drag brake will consume more power and heat will be increased, apply it cautiously.)

3B. Max. Brake Force

This ESC provides proportional braking function; the braking effect is decided by the position of the throttle trigger. It sets the percentage of available braking power when full brake is applied. Large amount will shorten the braking time but it may damage your pinion and spur.

3C. Brake Rate Control

It's adjustable from 1 to 20 (step: 1), the lower the brake rate, the more limit on the brake response. A suitable rate can aid the driver to brake his vehicle correctly. Generally, you can set it to a high value to have a quick brake response.

3D. Brake Frequency

The brake force will be larger if the frequency is low; you will get a smoother brake force when the value is higher. If set this item to "Customized", then the brake frequency can be adjusted to a variable value (which ranges from 0K to 16K) at any 0-100% throttle input. Please choose the frequencies as per the actual test results of your vehicles.

4A. Boost Timing

It is effective within the whole throttle range; it directly affects the car speed on straightaway and winding course. The ESC adjusts the timing dynamically as per the RPM (when "Boost Timing Activation" set to "RPM") or throttle amount (when "Boost Timing Activation" set to "Auto") in the operation. The Boost Timing is not constant but variable.

4B. Boost Timing Activation

Option 1: RPM

In RPM mode, the ESC adjusts the Boost Timing dynamically as per the motor speed (RPM). The actual Boost Timing is 0 when the RPM is lower than the Boost Start RPM. The Boost Timing changes as per the RPM when the RPM change is between the Boost Start RPM and the Boost End RPM. For example, if the Boost Timing is set to 5 degrees and the Boost Start RPM is 10000, the Boost End RPM is 15000. The Boost Timing corresponds to different RPM is shown below. When the RPM is higher than the Boost End RPM, the actual Boost Timing is the value you had previously set.

RPM (Motor Speed)	<10000	10001-11000	11001-12000	12001-13000	13001-14000	14001-15000	>15000
Actual Boost Timing	0 Degree	1 Degree	2 Degrees	3 Degrees	4 Degrees	5 Degrees	5 Degrees

Option 2: Auto

In Auto mode, the ESC adjusts the Boost Timing dynamically as per the throttle amount. Only at full throttle, the actual Boost Timing is the value you had previously set.

4C. Boost Start RPM

This item defines the RPM at which Boost Timing is activated. For example, when the Boost Start RPM is set to 5000, the ESC will activate the corresponding Boost Timing when the RPM goes above 5000. The specific value is determined by the Boost Timing and the Boost End RPM you had previously set.

4D. Boost End RPM

This item defines the RPM at which Boost Timing (you specifically set) is applied. For example, when Boost Timing is set to 10 degrees and the Boost End RPM to 15000, the ESC will activate the Boost Timing of 10 degrees when the RPM goes above 15000. The ESC will adjust the Boost Timing accordingly as per the actual RPM when the RPM goes below 15000.

5A. Turbo Timing

This item is adjustable from 0 degree to 64 degrees, the corresponding turbo timing (you set) will initiate at full throttle. It's usually activated on long straightaway and makes the motor unleash its maximum potential.

5B. Turbo Delay

When "TURBO DELAY" is set to "INSTANT", the Turbo Timing will be activated right after the throttle trigger is moved to the full throttle position. When other value(s) is applied, you will need to hold the throttle trigger at the full throttle position (as you set) till the Turbo Timing initiates.

5C. Turbo Increase Rate

This item is used to define the "speed" at which Turbo Timing is released when the trigger condition is met. For example, "6 degs/0.1sec" refers to the Turbo Timing of 6 degrees that will be released in 0.1 second. Both the acceleration and heat is higher when the "Turbo increase rate" is of a larger value.

5D. Turbo Decrease Rate

After the Turbo Timing is activated and the trigger condition turns to not be met (i.e. vehicle slows down at the end of the straightaway and gets into a corner, full throttle turns to partial throttle, the trigger condition for Turbo Timing turns to not met), if you disable the Turbo Timing in a moment, an obvious slow-down like braking will be felt and cause the control of vehicle to become bad. If the ESC can enable the Turbo Timing at some "speed", the slow-down will be linear and the control will be improved.

Warning! Boost Timing & Turbo Timing can effectively improve the motor efficiency; they are usually used in competitions. Please take some time to read this manual and then set these two items carefully, monitor the ESC & motor temperatures when you have a trial run and then adjust the Timing and FDR accordingly as aggressive Timings and FDR may cause your ESC or motor to burnt.

4 ESC Programming

1) Program your ESC with a multifunction LCD G2 program box

You can program this ESC via a multifunction LCD G2 program box or via a multifunction LCD G2 program box & a PC (HOBBYWING USB LINK software needs to be installed on the PC). Before programming, you need to connect your ESC and the LCD G2 program box through throttle cable and turn on the ESC; Press any button on the program box to initiate the communication between your ESC and the program box. Seconds later, you can adjust the setting via "ITEM" & "VALUE" buttons, and press the "OK" button to save new settings to your ESC.

2) Program your ESC with a OTA Programmer

This esc can also be programmed via a OTA Programmer along with smart phone devices (HW Link App software needs to be installed on the smart phone). Before programming, you need to connect the esc(throttle cable)and OTA Programmer via a "Y" shaped transfer cable. For detailed information about ESC programming via OTA Programmer, please refer to the user manual of Hobbywing's OTA Programmer.

Attention! This esc needs to use the throttle cable to connect the program box or OTA programmer.

5 Factory Reset

• Restore the default values with a multifunction LCD G2 program box

After connecting the program box to the ESC, continue to press the "ITEM" button on the program box until you see the "RESTORE DEFAULT" item, and press "OK" to factory reset your ESC.

• Restore the default values with a OTA Programmer (& HW Link App)

After connecting the OTA Programmer to the ESC, open the HOBBYWING HW Link App on your smart phone, select "Parameters" followed by "Factory Reset" to reset the ESC.

07 Explanation for LED Status

1. During the Start-up Process

- The RED LED turns on solid indicating the ESC doesn't detect any throttle signal or the throttle trigger is at the neutral position.
- The GREEN LED flashes rapidly indicating the neutral throttle value stored on your ESC may be different from the current value stored on the transmitter. When this happens, re-calibrate the throttle range.

2. In Running

- The RED LED turns on solid and the GREEN LED dies out when the throttle trigger is in the throttle neutral zone. The RED LED will blink quickly if the total value of Boost Timing and Turbo timing is 0.
- The RED LED dies out and the GREEN LED blinks when your vehicle runs forward. The GREEN LED turns solid when pulling the throttle trigger to the full (100%) throttle endpoint.
- The RED LED dies out and the GREEN LED blinks when you brake your vehicle. The GREEN LED turns solid when pushing the throttle trigger to the full brake endpoint and setting the "maximum brake force" to 100%.
- The RED LED dies out, the GREEN LED blinks when you reverse your vehicle. The GREEN LED turns solid when pushing the throttle trigger to the full brake endpoint and setting the "reverse force" to 100%.

3. When Some Protection is Activated

- The RED LED flashes a short, single flash and repeats "☆, ☆, ☆" indicating the low voltage cutoff protection is activated.
- The GREEN LED flashes a short, single flash and repeats "☆, ☆, ☆" indicating the ESC thermal protection is activated.
- The RED & GREEN LEDS flash at the same time indicating the drive mode has been automatically switched to sensorless mode from sensored mode because of abnormal sensor signal when pairing the ESC with a sensored motor.

08 Trouble Shooting

Trouble (s)	Possible Causes	Solution (s)
The ESC was unable to start		