

*Alpaon M*

## PRODUCT MANUAL

### SPECIFICATIONS

Wing span:	2222mm/87.5in
Length:	1000mm/39.4in
Wing area:	28.6dm <sup>2</sup> /444in <sup>2</sup>
Flying weight:	930-1025g 32.6-36oz
Wing loading:	32.5-35.8g/dm <sup>2</sup> 10.6-11.7oz/ft <sup>2</sup>
Propeller:	7"x5"
Battery & ESC:	3S 1300mAh 20A ESC
Radio required:	4-8channel radio system

### SAFETY PRECAUTIONS

This electric R/C model plane is not a toy.

Assemble the plane according to the instructions. Do not alter or modify the model, If you make any modifications, you will void your warranty.

Children under 14 years old must use it accompanied by an adult.

Test the operation of the model before each flight to insure that all equipment is operating properly, and that the model remains structurally sound.

Fly only on calm days (with wind speeds less than 10 mph) and in large open areas free of trees, people, building or any other obstacles.

#### REMEMBER:

Take your time and follow the instructions to end up with a well-built model that is durable and easy to fly.



## TABLE OF CONTENTS

<b>INTRODUCTION</b> .....1	Battery charging precautions .....8
Kit contents .....1	Check the control throws .....9
Replacement parts list .....2	Movement of All Control Surfaces.....11
<b>TOOLS REQUIRED</b> .....2	<b>FLYING THE ARCUS</b> .....12
<b>PREPARE THE RADIO CONTROL SYSTEM</b> .....2	Find a suitable flying site and weather .....12
<b>ASSEMBLE THE MODEL</b> .....4	Perform a range check .....12
Mount the landing gears .....4	Monitor you flight time .....12
Mount the spoilers .....5	Flight .....12
Mount the wings and horizontal stabilizer .....7	Launch sailplane by aerotow .....14
Check the C.G (Center of Gravity) .....8	Landing .....15
<b>GET THE MODEL READY TO FLY</b> .....8	After flight .....15

## INTRODUCTION

The Schempp-Hirth Arcus is a two-seater class glider in production by Schempp-Hirth. It first flew on 7 April 2009. It is available as a pure glider, uncoupled from the tow plane, and as a self-launching glider using a motor.

The model is equipped with an innovative propeller drive that retracts automatically. When the drive is retracted the whole propeller unit disappears into the fuselage. You always can equip the plane with the retractable landing gear, and the spoilers on the wing. Fuselage, wings and stabilizers are made of hypodur---a light weight and strong material. They are also reinforced with carbon bars. The Arcus is more than 90% preassembled. So it takes only a few minutes to get the model ready for take off.

Wish you have a good flight! And you shall read through the manual before you begin, so you will have an overall idea of what to do.

## Kit Contents

Before starting to build, inspect the parts to make sure they are of acceptable quality. If any parts are missing or not of acceptable quality, or if you need assistance with assembly, contact Product Support. When reporting defective or missing part, use the part names exactly as they are written in the Kit Contents List.

01. Fuselage .....x1	08. Wing Connector .....x1
02. Hatch .....x1	09. Transmitter .....x1
03. Left Wing .....x1	10. Battery Park .....x1
04. Right Wing .....x1	11. Charger .....x1
05. Stabilizer .....x1	12. Decals .....x1
06. Screw M4.0x20 .....x1	13. Product Manual .....x1
07. Screw M3.0x12 .....x1	

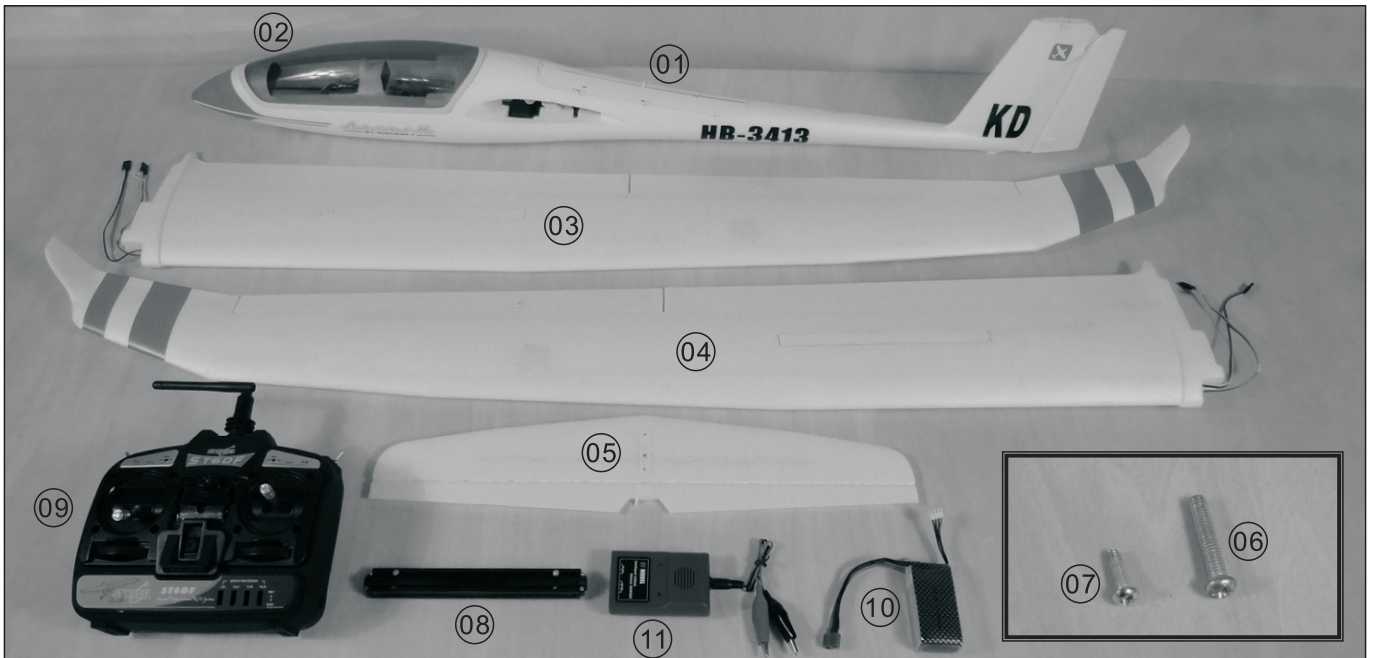

## Replacement Parts List

Replacement part for the ST MODEL Arcus are available using the numbers in the Replacement Parts List that follows.

Order NO.	Description	Order NO.	Description
ST 106	11.1V LiPo 1300mAh	ST 202	7x4 Propeller
STAR 010	Fuselage Set	ST 110	20 AMP ESC
STAR 020	Wing Set	STAR 013	RMS Control Mixer
STAR 021	Wing Connector	ST 102	9g Servo
STAR 030	Stabilizer	STAR 104	26g Servo
STAR 050	Landing Gear Set	ST 103	3S LiPo Smart Balancing Charger
STAR 011	Motor Gear Set	ST 106	ST 6DF 2.4GHz Transmitter
STAR 022	Spoiler Set	ST 105	ST 6DF 2.4GHz Receiver
STAR 012	Hatch		

## TOOLS REQUIRED

- Sharp Hobby Knife

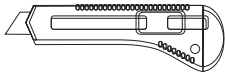

- Phillips Screwdrivers (size:M,S)

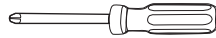

- Awl

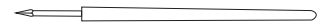

- Needle Nose Pliers

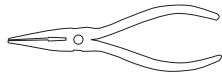

- Flathead Screwdrivers (size:M,S)

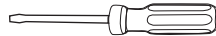

- Ruler



- Hex Wrench

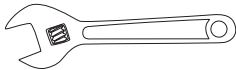

## PREPARE THE RADIO CONTROL SYSTEM

1. Locate the transmitter (PIC.01).
2. The transmitter requires eight alkaline "AA" batteries. To install the batteries, remove the battery hatch by sliding it down and inserting them into place (PIC.02). Be sure to follow the polarity diagram inside the battery compartment. Reinstall the battery hatch (PIC.03).

### CAUTION:

- (1). Do not use rechargeable (NiCd & NiHy) batteries.
- (2). Do not mix old and new batteries.
- (3). Do not mix alkaline and standard (carbon zinc) batteries.

3. Switch the transmitter on and check the LED on the front of the transmitter (PIC.04). If the green LED is on, it is safe to fly. If the red LED is flashing, install fresh batteries. Also check to make sure that the batteries are installed correctly.
4. Switch the transmitter off and stand by for later use.

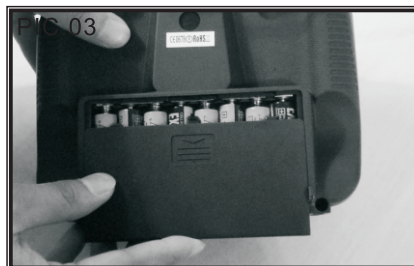
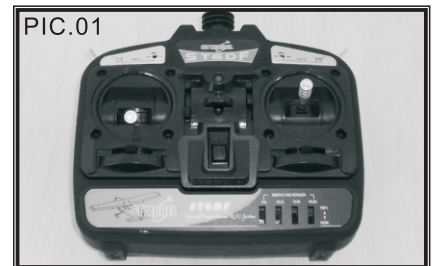

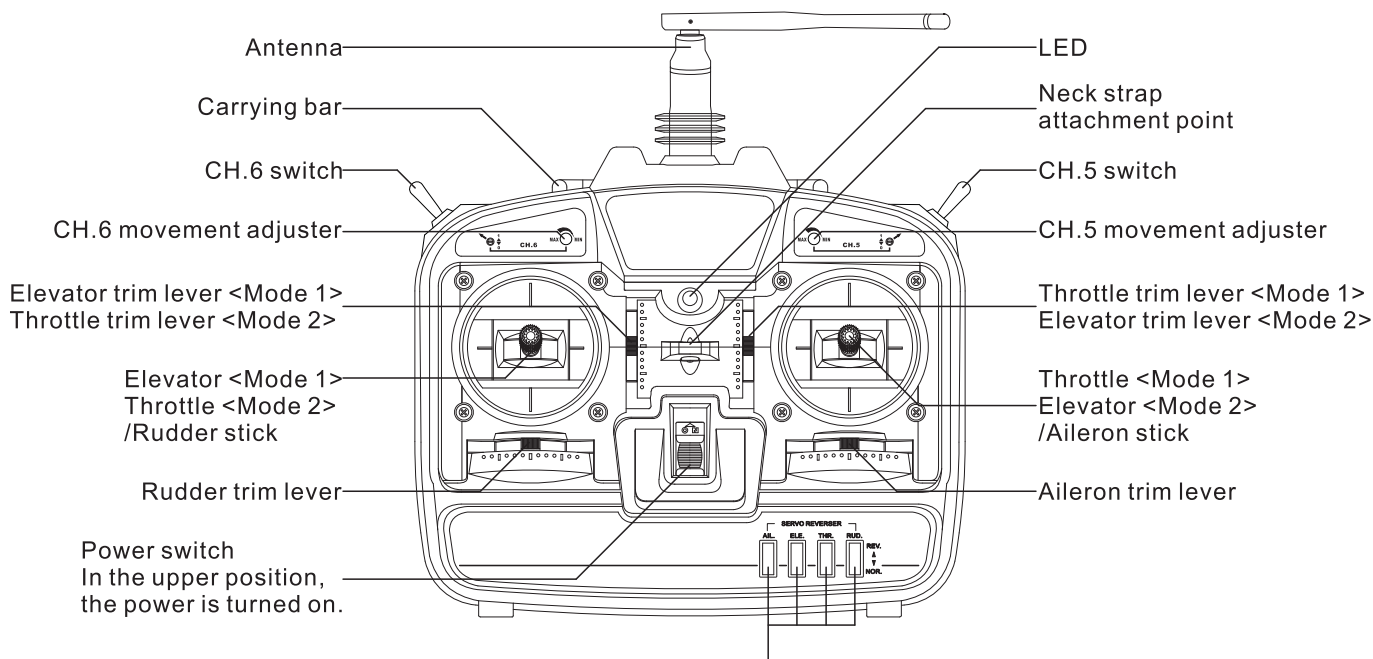

Channel display	Operating direction display
AIL. : Aileron	REV. : Reverse side
ELE. : Elevator	NOR. : Normal side
THR. : Throttle	
RUD. : Rudder	

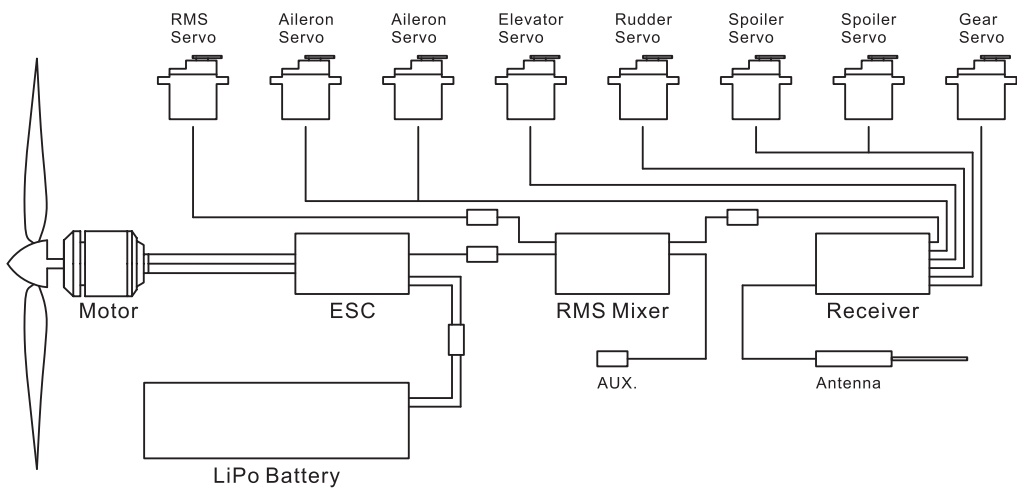

**RMS (Retractable motor system):**

The motor is installed on the retractable gear! Motor system will be unfolded from the fuselage when the plane needs to climb, and the motor runs the propeller to provide thrust. When the plane is in the situation of glide, the motor system will be retracted into the fuselage to reduce the drag.

**Flying mode switch:**

There are two flying mode of RMS: "NORMAL" mode and the "AUTO" mode, it is switched by a selector switch on the transmitter. The RMS is always unfolded when the "NORMAL" is on, the throttle stick (CH.3) just control the motor speed; When you choose the "AUTO" mode, the folding/unfolding of RMS will be controlled by the throttle stick in special process, while the throttle stick will control the motor speed. If the flying mode switch connector of RMS mixer is connected to nothing, the RMS of the plane will work in "AUTO" mode.

**NOTE:**

You can know the RMS Mixer how to works follow <<RMS Control Mixer Instruction Manual>>.

# ASSEMBLE THE MODEL

## Mount the Landing Gears

1. If your plane is not equipped with the landing gears (PIC.05), you can mount them by yourself as follows:
  - (1). Main undercarriage module
  - (2). Nose undercarriage module
  - (3). Micro servo (9g) with screw-lock connector
  - (4). Pushrod wire
  - (5). Tapping screws M3.0x8 x 2pcs
  - (6). Tapping screws M2.5x8 with washer x 2pcs

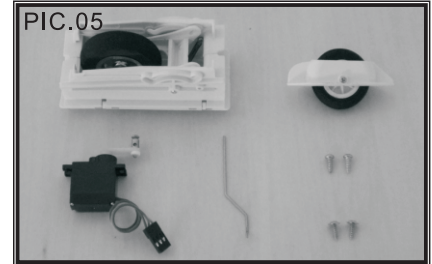

2. Remove the foam fillings from the undercarriage locations carefully (PIC.06).
3. Set the tapping screws M3.0x8 into the locations on the main undercarriage as illustration (PIC.07).

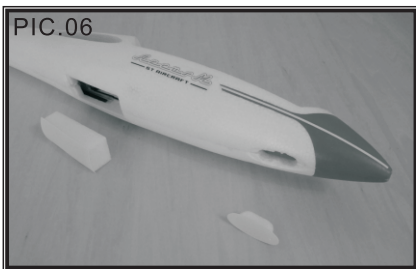

4. Connect the pushrod to the hole in the locker of main undercarriage. Install the main undercarriage module into the fuselage in right direction (PIC.08). Then tighten the screws to lock the module (PIC.09).
5. Mount the nose undercarriage module into the fuselage in right direction. A little glue such as CA is necessary for the mounting (PIC.10, PIC.11).
6. Center the micro servo by the R/C radio or servo tester be careful about the length of servo arm as picture shows. (PIC.12). Install the servo in its location, then lock it with tapping screws M2.5x8 (PIC.13).
7. Guide the pushrod wire into the screw-lock connector on the micro servo (PIC.14). But do not tighten the screw yet.

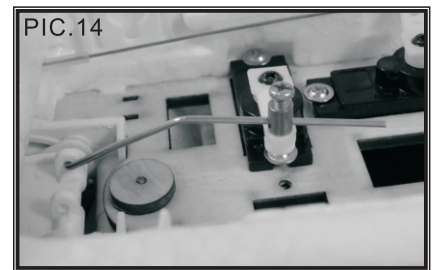
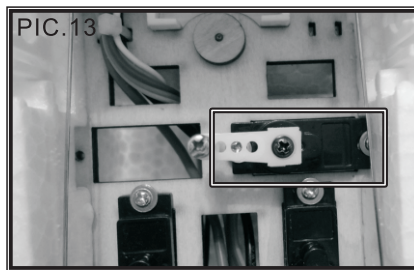
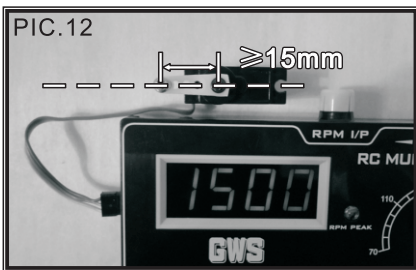
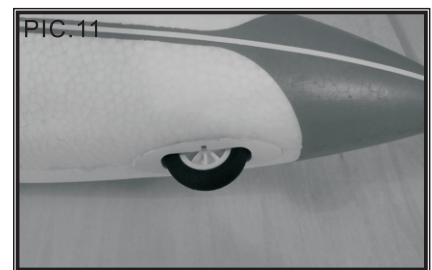
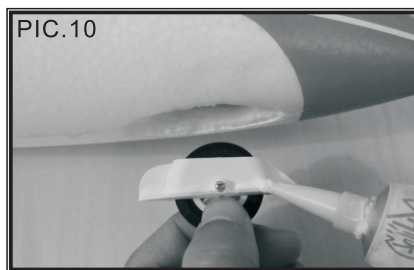
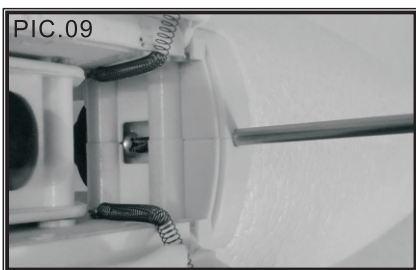

8. Connect the undercarriage servo wire to CH.5 socket in the receiver (PIC.15). With the transmitter and receiver on, and switch the CH.5 to "0" position (means the landing gear is "UP") (PIC.16).
9. Pull the pushrod of undercarriage forward to the end, ensure the servo arm is the position as picture (PIC.17). Then tighten the screw lock the pushrod down.

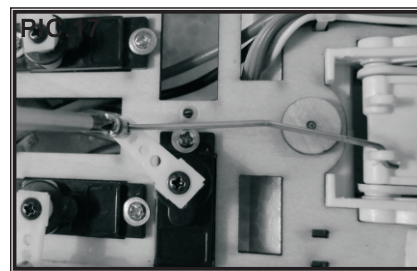
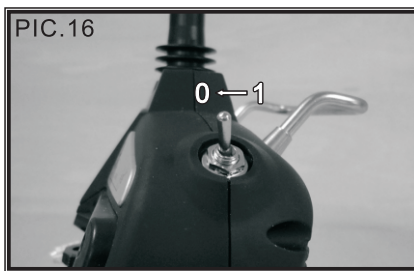

## *Mount the Spoilers*

1. If your plane is not equipped with the spoilers (PIC.18), you can mount them by yourself as follows:
  - (1). Left & right spoilers
  - (2). Micro servo (9g) with 300mm wire x 2pcs
  - (3). Pushrod wires x 2pcs
  - (4). Tapping screws M2.0x6 x 8pcs
2. Cut the wing along the center of groove carefully by sharp knife (PIC.19). Then remove the foam filling from the wing (PIC.20).

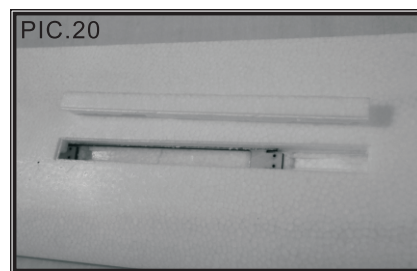
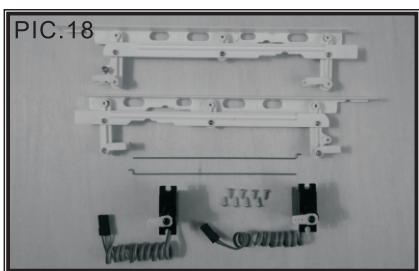

3. First, center the servo by the R/C radio or servo tester (PIC.21). Insert the "z-bend" of the pushrod wire into the hole of the servo horn. Be careful about the length of servo horn as photo shows (PIC.22).
4. Remove the servo cover of spoiler from the wing (PIC.23). Then insert the other end of pushrod through the wing to the location of spoiler (PIC.24 PIC.25). You can wind some tape on the end of pushrod before passing it through the wing to avoid puncturing the wing (PIC.26).

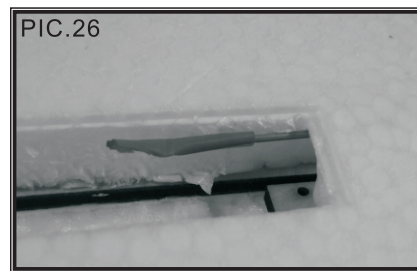
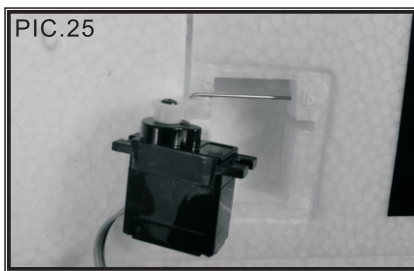
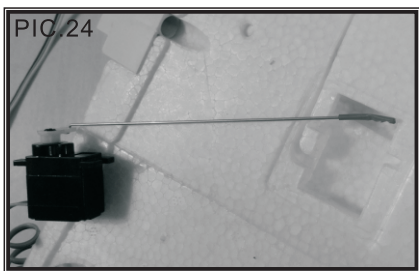
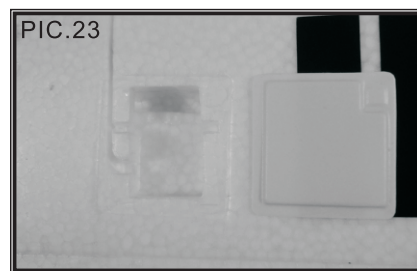
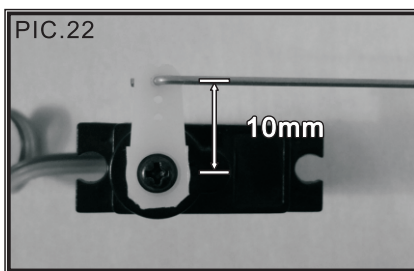

- Stick the servo into the wing by double-sided adhesive (PIC.27 PIC.28).
- Take the angle strip down from the spoiler module, then mount the spoiler module into the wing with tapping screws M2.0x6 (PIC.29).

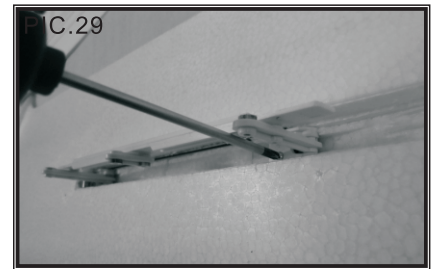
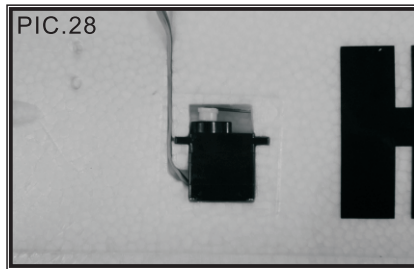
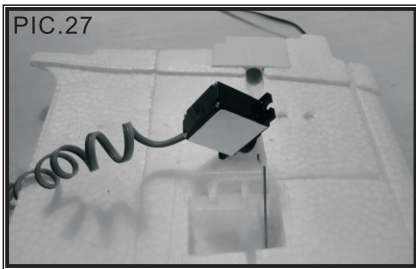

- Connect the spoiler servo wire to CH.6 socket in the receiver (PIC.30). With the transmitter and receiver on, and switch the CH.6 to "1" position (means the spoiler is folded into wing) (PIC.31).

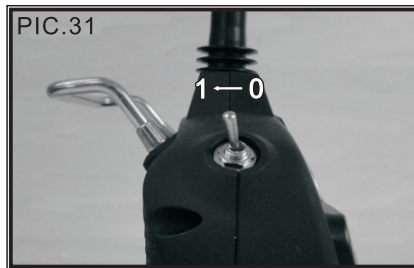
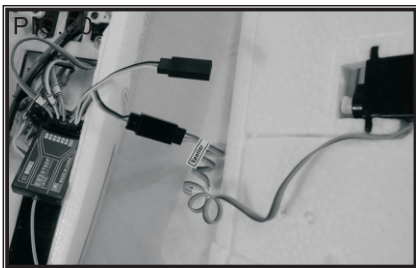

- Fold the spoiler into the wing completely, and lock the pushrod into the metallic connector with screw to avoid loosening (PIC.32).
- Switch the CH.6 to "0" position (PIC.33), the spoiler will unfold from the wing. Then mount the angle strip on the spoiler (PIC.34).

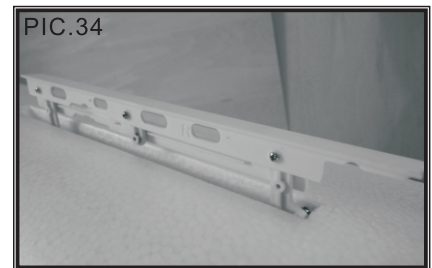
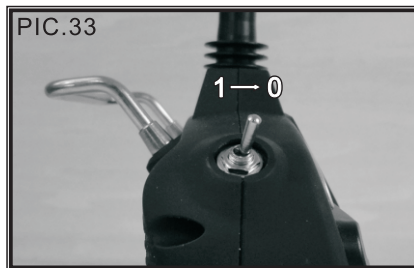
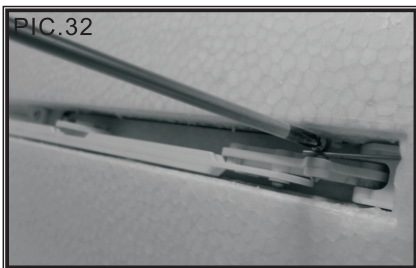

**NOTE:**

Do not tighten the screws on spoiler to avoid locking the spoiler. You can screw the screws anticlockwise half lap after tightening the screws (PIC. 35).

- Fasten the servo wire into the groove on the wing, then cover it with the glue such as CA (PIC.36). Replace the servo cover on the wing with some glue, hold it in place with tape before the glue solidify (PIC.37).

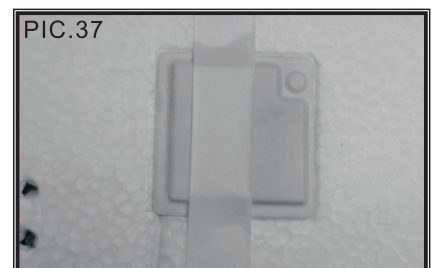
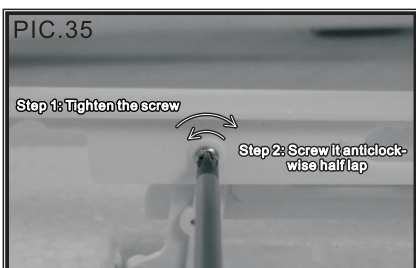



## Mount the Wings and Horizontal Stabilizer

1. Parts for mounting the wings and horizontal stabilizer (PIC.38).
  - (1). Fuselage & Hatch
  - (2). Left & right wing
  - (3). Horizontal stabilizer
  - (4). Screw M3.0x12
  - (5). Screw M4.0x20
  - (6). Wing connector
2. Install the "Z" end of push rod to the horns of elevator (PIC.39).
3. Mount the horizontal stabilizer on the holder on fin. And fix it with the screw M3.0x12 to avoid loosening (PIC.40).

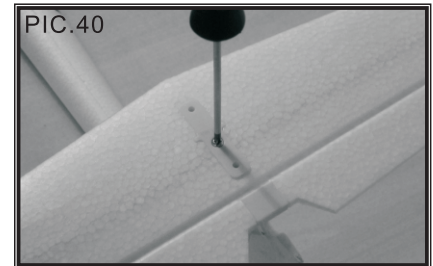
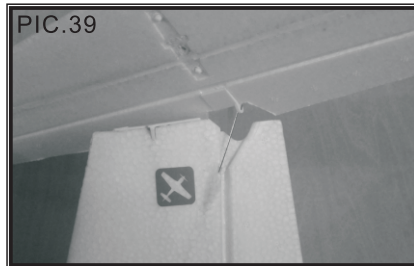
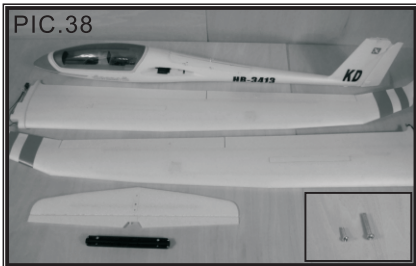

4. Insert the wing connector into one of the wings correctly (PIC.41). Then put the aileron servo & spoiler servo wires through the fuselage into the canopy as picture shows (PIC.42).
5. Please put the wing connector through the fuselage and insert to the other wing, and put the aileron servo & spoiler servo wires into the canopy as above step (PIC.43).

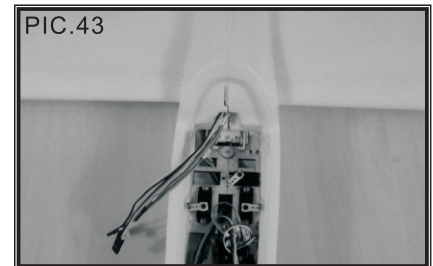
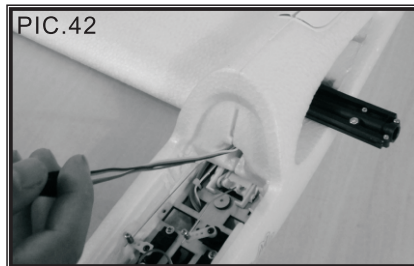
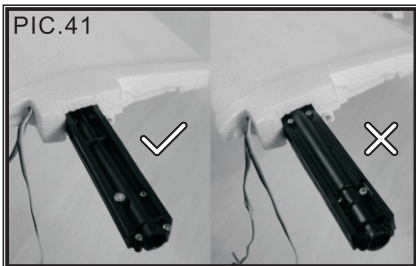

6. Take the aileron servo wires and connect to the servo extension leads. Ensure the polarity should be contacted correctly (PIC.44).
7. Fit the wings and the fuselage in place with the screw M4.0x20 (PIC.45). You also can tighten the screws on the connector under the wings to avoid the wings loosening (PIC.46).

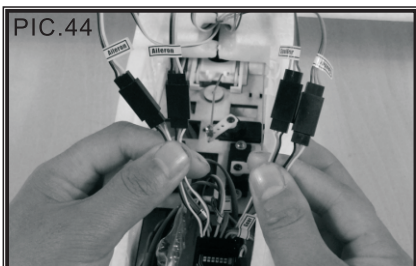

## ***Check the C.G. (Center of Gravity)***

The C.G. (Center of Gravity) is the location on the wing where the model balances and has a great effect on how it will fly. If the C.G. is too far aft (tail heavy), the model will be too responsive, and the glider with propeller stopped will descend at a steeper angle with decrease in airspeed. If the C.G. is too far forward (nose heavy), the model will not be responsive enough, and the glider with propeller stopped will descend at a smooth angle with increase in airspeed.

As provided to you, Arcus should already be properly balanced or very nearly properly balanced, but it's a good idea to check the balance just in case. Follow the illustrations to make sure the model is balanced properly and C.G. is in the correct location.

1. Install the motor battery, but do not connect it to the ESC. Also install the hatch. All the rest of the parts of the plane should already be installed.
2. The standard C.G. of this plane is positioned at the 45mm behind the leading edge of wing root when the RMS is completely folded (PIC.47). If the RMS is completely unfolded, the C.G. is positioned at the 40mm behind the leading edge of wing root (PIC.48).
3. We recommend only use the battery pack intended for Arcus, or use the same weight and performance battery packs. If the battery pack or other accessories have changes please recheck the C.G. position according to the content above.
4. If the C.G. of plane is not in the position recommended above, you should adjust the C.G. by adding the balance weight on nose or tail of fuselage. For example, if the C.G. is too far aft (tail heavy), you can add the nose balance weight in the front of cockpit (PIC.49).

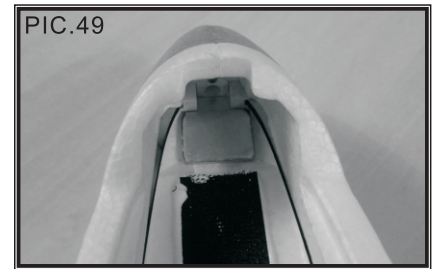
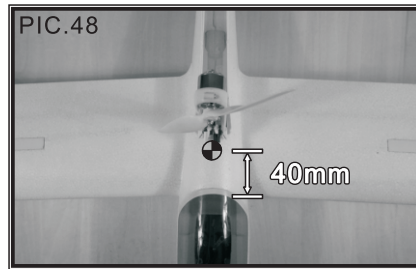
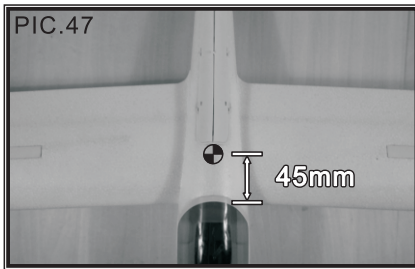

## ***GET THE MODEL READY TO FLY***

### ***Battery Charging Precautions***

Arcus is equipped with a 3C-11.1V LiPo battery (PIC.50) and a LiPo battery cell balancing charger (PIC.51). The LiPo battery has two connectors; one is for cell balance charging and the other is for discharging. The charger has a barrel connector with alligator clips for DC input voltage and two output sockets for balance charging. One of outputs is for 2-cell LiPo battery pack and the other is for a 3-cell LiPo battery pack.

#### **CAUTION:**

- (1). Only charge the LiPo battery with a LiPo battery balance charger.
- (2). This is a lithium polymer battery charger, which just match to the LiPo battery installed in Arcus. Do not charge other types of batteries.

1. Connect the charger to the 11-14V DC power supply and then the red & green LED will light a sec (PIC.52). Ensure the current capacity of the power supply is 1A or higher.

#### **CAUTION:**

DC power must meet the requirements above, or charger will work incorrectly and maybe damage on the charger & battery. Before charging, disconnect the battery with any power. During the charging process, keep the charger in a normal temperature area and away from any source of ignition. Do not cover the charger or battery pack with carpet, clothes or anything else. Air circulation is necessary for proper cooling.

2. Plug the balance connector of the battery pack to the four-pin output socket of the charger (PIC.53). Be careful the battery will plug in only one way. Do not force the plugs. Observe the red LED is on solid (PIC.54).

#### **NOTICE:**

Please connect the charger to the power sources before connecting the battery pack.

3. **IMPORTANT!** Never leave a charging battery unattended. Please stop the charging operation if the charger appears to be performing abnormally. Please stop charging immediately if the battery temperature rises rapidly or it swells.
4. When the battery pack is fully charged, the red LED will turn off, and the green LED will on.  
Warning:  
Disconnect the battery with the charger first and then disconnect the power with the charger when it is finished. Please choose the power, battery and transmitter or it will reduce the longevity under the incorrect improvements.

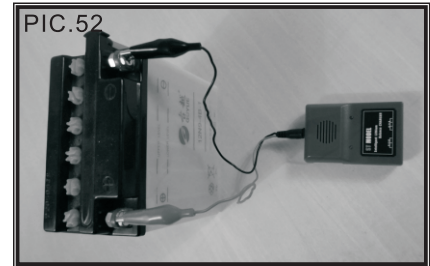
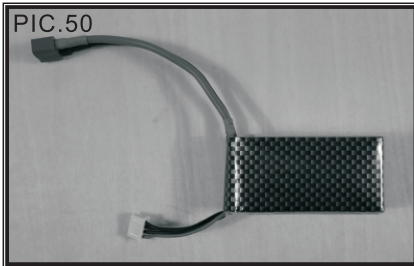

### ***Check the Control Throws***

1. Test the power system and RMS:
 

The Arcus RTF version includes a RMS control mixer, which can guarantee the RMS works well, so before the test, you should know the mixer how to works follow <RMS control mixer instruction manual>.

  - (1). Switch on the transmitter and connect the battery to airplane. Push the throttle stick and its trim to the min (PIC.55). The ESC will be armed after you hear the music.
  - (2). Slide the throttle stick upward slowly about 2°. There is a position of unfolding/folding as the illustration (PIC.56), the RMS will unfold (PIC.57).
  - (3). Keep sliding the throttle stick upward slowly (PIC.58), the speed of propeller will be faster gradually (PIC.59).
  - (4). Slide the throttle stick downward to the min (PIC.60), and the RMS will be retracted into the fuselage as the following steps.

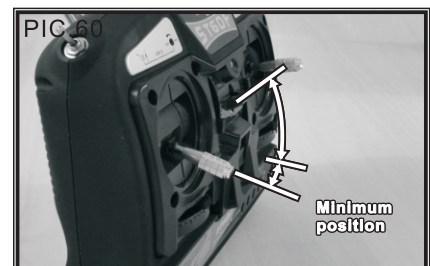
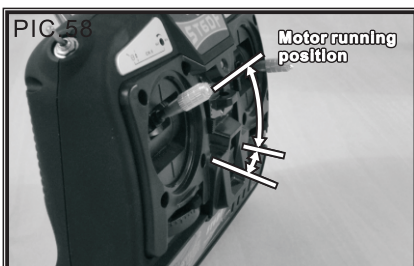
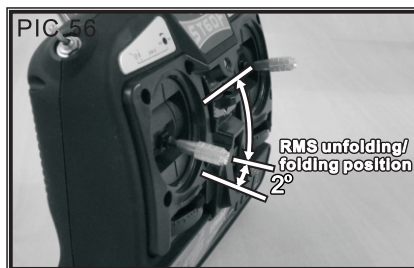
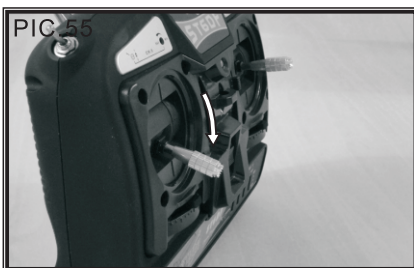

- A. The ESC stop to power the motor, and the RMS starts to fold (PIC.61).
- B. The RMS is retracted to "propeller stop" and keep waiting 3 sec. On this position, the stopgear will stop the propeller (PIC.62). Because there is no airstream on the ground, so it can't assure that the propeller will stop upright automatically (PIC.63). Then you can set the propeller upright by tools (PIC.64).
- C. RMS is folded inside of the fuselage completely (PIC.65).

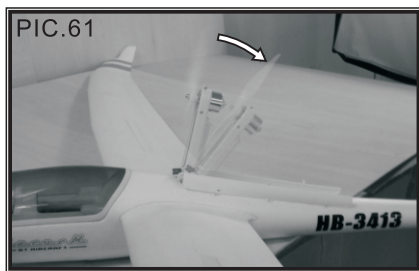

2. Test the aileron:

- (1). Move the aileron control stick to the left, the left aileron moves up and the right one moves down (PIC.66).
- (2). Move the stick to the right, the left aileron moves down and the right one moves up (PIC.67).
- (3). Move the stick to its neutral position, the aileron returns its neutral position (PIC.68).

**NOTE:**

If the movement of aileron works in opposite, please check the aileron reverse switch on the transmitter and make necessary alignment.

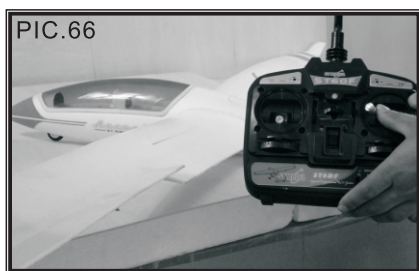

3. Test the rudder:

- (1). Move the rudder control stick to the left, the rudder turn to the left (PIC.69).
- (2). Move the stick to the right, the rudder turn to the right (PIC.70).
- (3). Move the stick to its neutral position, the rudder return theirs neutral position (PIC.71).

**NOTE:**

If the movement of rudder works in opposite, please check the rudder reverse switch on the transmitter and make necessary alignment.



4. Test the elevator:

- (1). Move the elevator control stick backward, the elevator will be up (PIC.72).
- (2). Move the stick forward, the elevator will be down (PIC.73).
- (3). Move the stick to its neutral position, the elevator return theirs neutral position (PIC.74).

**NOTE:**

If the movement of elevator works in opposite, please check the elevator reverse switch on the transmitter and make necessary alignment.



5. Test the landing gear:

(1).CH.5 switch is at the "0", landing gear is retracted into fuselage (PIC.75).

(2).CH.5 switch is at the "1", landing gear is deployed (PIC.76).

**NOTE:**

If the landing gear not be locked after extending, please adjust the "EPA OF CH.5" on the corner of transmitter to have the landing gear extended completely and been locked. But don't keep the driving servo in long-time load with the sizzle, it will be very easily to damage the servo (PIC.77).

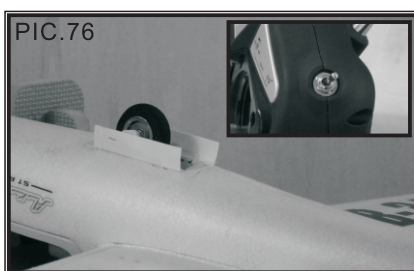

6. Test the spoiler:

(1).CH.6 switch is at the "1", spoiler is folded into the wing (PIC.78).

(2).CH.6 switch is at the "0", spoiler is unfolded (PIC.79).

**NOTE:**

If you want to adjust the travel of spoilers, you can adjust the "EPA OF CH.6" on the corner of transmitter (PIC.80).

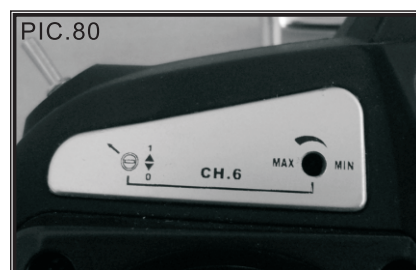
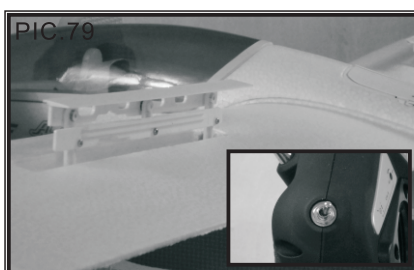

***Movement of All Control Surfaces***

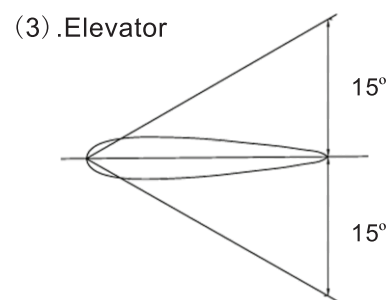
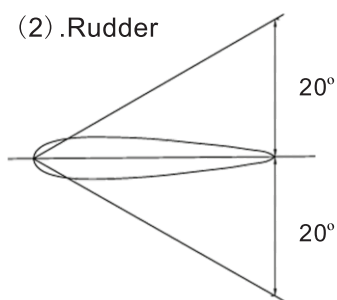
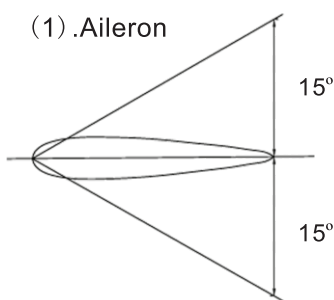

## ***FLYING THE ARCUS***

### ***Find a Suitable Flying Site and Weather***

1. The Arcus should be flown only when the wind speed is 15 mph or less. It will be easy to control if the wind is calm or very light. Only fly the Arcus when the wind speed is less than 5 mph if you have no experience of flying; if you are an experienced pilot, please fly it when the wind speed is 15 mph or less; if fly it in stronger winds, the plane would be blown down then couldn't recover due to lack of power. Don't fly the plane in rain or snow.
2. Choose a large open flying site. It would be better if there is a flat, dry, long and wide enough ground (such as concrete ground) as runway. In a calm day, the ideal size of runway for Arcus should not be less than 40mx5m. The site should be free of power line, tree and away from railway, highway, parking lot and building. Don not fly around ground of people, especially children. Lawn is a good site for Arcus to land with the landing gear retracting. But the plane cannot achieve its normal speed when take off from the lawn. It would be better if flown in a site for flying RC planes.
3. Don't fly in aviation control areas or military bases.

### ***Perform a Range Check***

As a precaution, an operational ground range test should be performed before the first flight each time you go out. Performing a range test is a good way to detect problems that could cause loss of control such as low batteries, defective or damaged radio components or radio interference. This usually requires an assistant and should be done at the actual flying site you will be using.

First turn on the transmitter, then install the fully-charged battery into the fuselage. Connect the battery and install the hatch.

Remember, use care not to "bump" the throttle stick. Otherwise, the propeller will turn and possibly cause damage or injury.

Follow the instructions that came with your radio control system to perform a ground range check. Make sure you operate the motor and vary the rpm while performing the check. Have your assistant alert you if the controls quit responding or move suddenly erratically.

If the controls aren't working correctly or if anything seems wrong, don't fly the model until you find and correct the problem. Make certain all the servo wires are securely connected to the receiver and that the transmitter batteries are in good condition.

### ***Monitor Your Flight Time***

Monitor and limit your flight time using a timer (such as one on a wrist watch or in your transmitter if yours has one). When the batteries are getting low you will usually notice a performance drop before the ESC cuts off motor power, so when the plane starts flying slower you should land. Often (but not always), power can be briefly restored after the motor cuts off by holding the throttle stick all the way down for a few seconds.

To avoid an unexpected dead-stick landing on your first flight set your timer to a conservative 5 minutes (in most conditions the Arcus will usually fly for approximately 10 minutes, but this can vary). When your alarm sounds you can either land right away, or if you are an experienced pilot you may continue to fly until the motor finally quits. Then, glide it in for a landing. If planning a "dead-stick", circle your upwind of the landing area until the motor quits and note the run time.

When you learn how much flight time you are getting you can adjust your timer accordingly. Always be conservative so the motor won't quit unexpectedly and you will have enough battery to land under power.

### ***Flight***

The Arcus 6 channel kit is equipped with spoilers as the real aircraft. Spoilers are movable control surfaces in the top of the wing. They can be raised into the air-flow to eliminate the lift from the wing area behind the spoiler, disrupting the span wise distribution of lift and increasing lift-induced drag. We recommend a little amount of spoiler extending when you glide the glider to land. The glider will descend at a steeper angle with decrease in airspeed after the spoiler extending to reduce the distance of landing.

If you have never flown an R/C airplane before, we recommend that you get help from an experienced R/C pilot. Most R/C clubs have training programs that will help you learn to fly quickly. If you cannot find an experienced pilot to help you learn, you can exercise your flying skill with a "R/C flight simulator" on personal computer. And the following will help you get your plane into the air.

1. First, turn your transmitter power switch "ON". Ensure the power control stick is at the lowest position and the trim lever is at the neutral position.
2. Connect the battery with the plane. The RMS will raise and the propeller will rotate fast if you pull the power control stick to a higher position.  
**CAUTION:**  
Stay clear of the propeller.
3. Ensure the landing gear is extended to be locked and the spoilers are folded completely, place the plane at the starting point of the runway against the wind. Then move the throttle control stick to its top position, and the plane speeds up. The plane will not keep running straight during the speeding up, you need to adjust by moving the rudder or aileron control stick. When it has enough for take off, pull the elevator control stick toward you slightly, the plane will lift from the ground naturally. We also recommend you launch Arcus into the air by an assistant.
4. Let the plane climb at an angle from 10-30 degrees for several seconds. You can put the elevator control stick in its neutral position once the angle of climb is too large and pull it slightly when necessary. Then retract the landing gear and take a turn.
5. When the plane is moving away from you, move the aileron control stick to the left, combined with a small amount of up elevator, your plane will turn left; move the aileron control stick to the right, your plane will turn right. To stop the turn, move the stick the opposite direction until the plane is flying level and return the elevator to center.  
**CAUTION:**  
Only a small amount of up elevator is needed here.
6. When the plane is coming toward you, move the aileron control stick to the left. But the plane flies to your right. That is to say, you have to reverse the way to control ailerons when the plane flies toward you. Here's a good way for you, you can turn your body when the plane flies toward you so that you are facing the same direction the plane is flying to; you can look at the plane over your shoulder. Now when you move the aileron control stick to left the plane will fly to your left.
7. When the plane climbs to a high enough altitude, you can adjust the trim lever to maintain straight and level flight. When you loose the elevator control stick, if the plane tends to nose up, you can push the elevator trim lever to the direction away from you; if the plane tends to nose down, you can push the elevator trim lever to the direction towards you. Only a small amount of adjustment should be OK. If the plane doesn't go as you adjusted, you can adjust twice or more. Your goal is to get the plane fly level or climb at a very small angle (like 0-5 degrees) with the elevator, throttle control stick at their neutral position and the throttle stick moved fully up.
8. For beginners, rudder is mainly used for take off and landing. During take off and landing, it is necessary to control the plane turn to left or right by controlling the rudder, instead of controlling the aileron. Move the rudder control stick to the left will make the plane turn to left; move this stick to the right will make the plane turn to right. If the plane tends to turn with the left stick centered, move the rudder trim lever opposite the direction the plane is turning.
9. With the plane flying level, check to see if the plane is flying straight. Move the aileron control stick in neutral position, if the plane wants to turn, move the aileron control trim lever opposite the direction the plane is turning. Then the plane is trimmed OK. If you take your hands off the sticks, the plane will fly straight and level on its own. Having the plane trimmed properly makes flying much easier and more enjoyable.
10. Don't let the plane get too far away from you. The farther away it is, the harder it is to see what the airplane is doing. Especially when the battery runs low, you should control the plane back to you immediately.
11. When learning to fly, it is best to keep the plane high enough so that you have enough altitude to correct it if you make a mistake.

## Launch Sailplane by Aerotow

1. If you want to launch your glider by aerotow, you can mount a tow hook in you plane (PIC.81).
  - (1). Tow hook wire
  - (2). Micro servo (9g) with screw-lock connector
  - (3). Power supply (DC 4.8V for receiver)
  - (4). Ballast
2. Center the servo arm by the R/C radio or servo tester. And install the servo to the fuselage in right direction with tapping screws (PIC.82).
3. Guide the tow hook wire into the hold as picture shows (PIC.83), then guide the other end of tow hook into the screw-lock connector on servo arm (PIC.84). But do not tighten the screw yet.
4. Connect the servo wire to CH.3 (Throttle) socket in the receiver. With the transmitter on and power the receiver with DC 4.8V power supply (PIC.85).
5. Push the throttle stick to top position, the servo arm should rotate to forward (PIC.86) (If not, please reverse the throttle channel on the transmitter). Align the end of hook wire with tip of fuselage (PIC.87), then tighten the screw on servo arm to lock the hook wire down (PIC.88).
6. Please check the C.G position again. Then add the necessary ballast in the fuselage.
7. Tie a ring on the end of towline (PIC.89). Then hang it into the tow hook as illustration (PIC.90). Tie the other end of towline to aerotow.

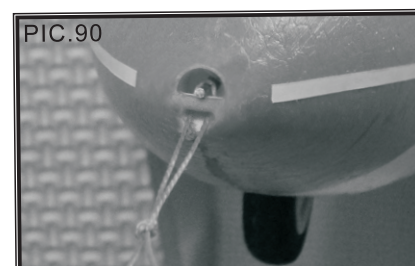
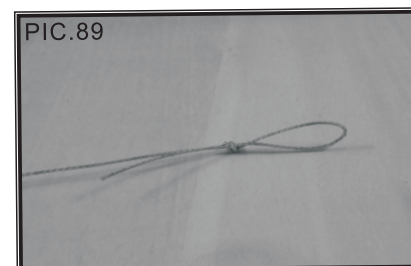
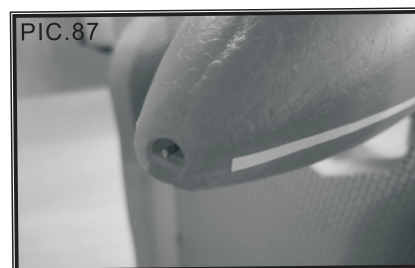
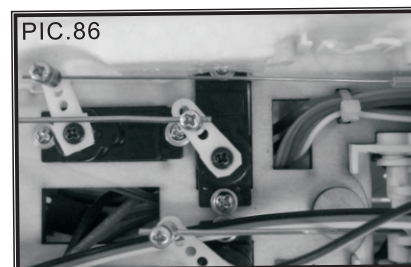
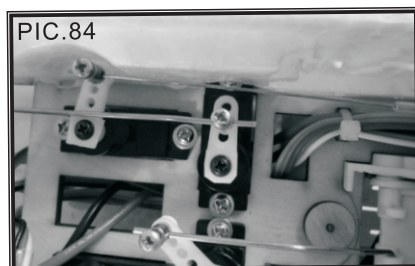
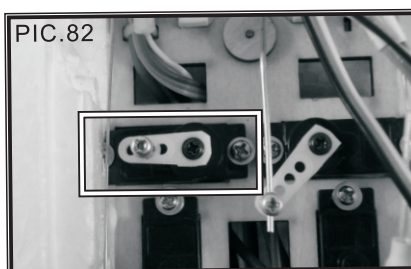
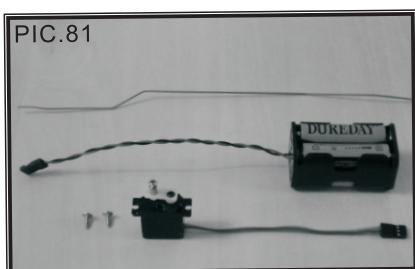



## ***Landing***

It's time to land the plane now. The problems you are facing are where and how to land it.

1. For the sake of safety, you should land the plane before the battery exhausted if you are a beginner. The power system of Arcus comes with "Auto Cut Off" feature which reserves battery power for safe landing.
2. During the first flight, while at a high altitude, turn the motor off and retract the RMS, switch the CH.6 to open up the spoilers, and switch the CH.5 to deploy the landing gear. Then notice how the plane reacts. This will give you an idea of how the plane will react during a landing.
3. To land the Arcus, fly down wind, past the landing area. Gently turn into the wind and reduce the speed so that the plane starts to come down. Retract the spoilers when needed to reach the landing area, but not fly past it. Get the plane 1m or 2m above the ground when it is closed to the landing area.
4. Just before landing, at about 0.5m above the ground, apply a little up elevator to make the plane nose up (not to make it climb). This will cause the plane to slow and settle to the ground. When the plane is sliding on the ground, you can control the plane to run straightly by moving the rudder & aileron control stick till it stops. Please don't force it to stop by your body or anything else.

**CAUTION:**

If the landing is unsuccessful, pull the throttle control stick to its lowest position immediately. Because during a rough landing, the propeller should become jammed and cannot rotate with the throttle in the run position, the battery, speed control and the motor will become very hot. Immediately move the throttle lever down to stop the motor. If you fail to do this, the motor, speed control or the battery would be damaged.

## ***After Flight***

Unplug the battery with the plane and switch off the transmitter. Allow enough time for the motor and battery to cool before recharging. Check the plane carefully and make sure no parts have gotten loose or damaged.



SHENG TENG ELECTRIC R/C MODEL PLANE CO.,LTD

[www.sheng-teng.com](http://www.sheng-teng.com) [shengteng@263.net.cn](mailto:shengteng@263.net.cn)