



Pro Scale® LED Light Kit Installation Instructions

Covers Part #9883

Kit Contents:

- LED headlights/tail lights harness assembly
- Zip ties (6)

Tools required:

- 1.5mm hex wrench
- Side cutters (to trim zip ties)

BODY DISASSEMBLY

1. Remove zip ties (3).
2. Remove front LED headlight retainers and light harness.

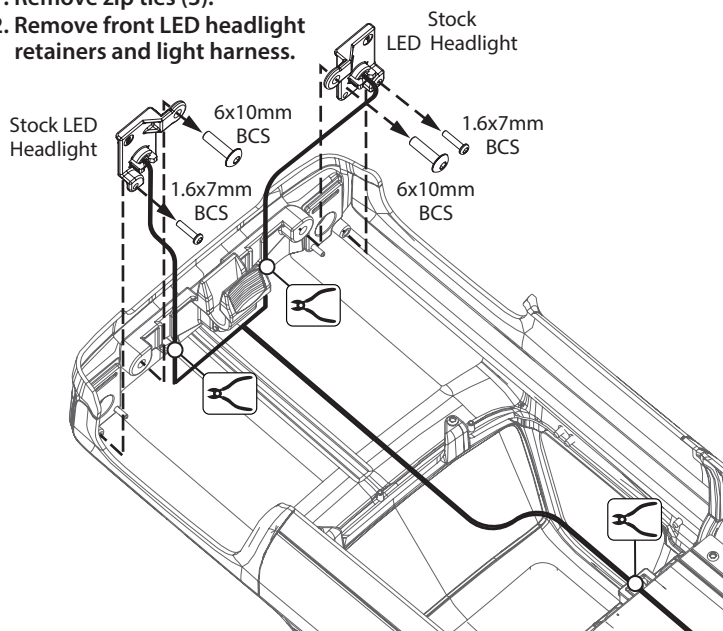

Note: Retain and reuse hardware. Discard the parts or save for future use.

3. Remove the existing tail light housings.

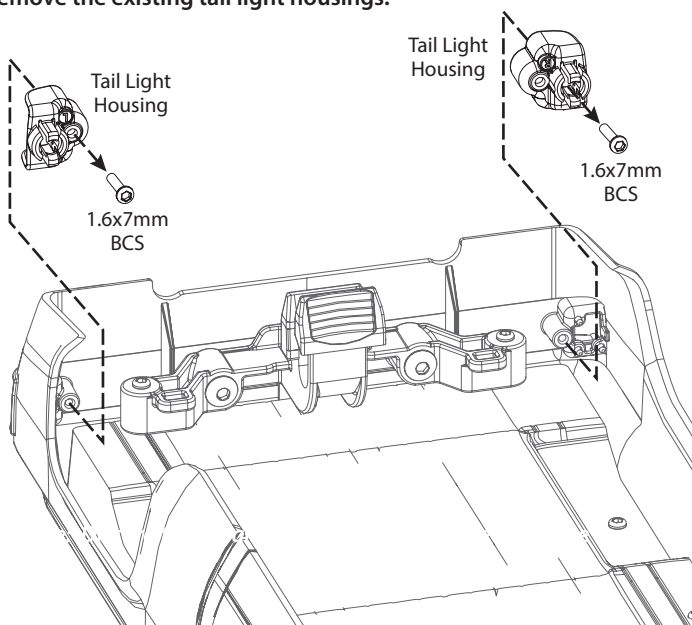

LED LIGHT INSTALLATION

1. Install the left and then right LED headlight assemblies (A).
2. Route both LED tail light assemblies toward the rear of the body (B).

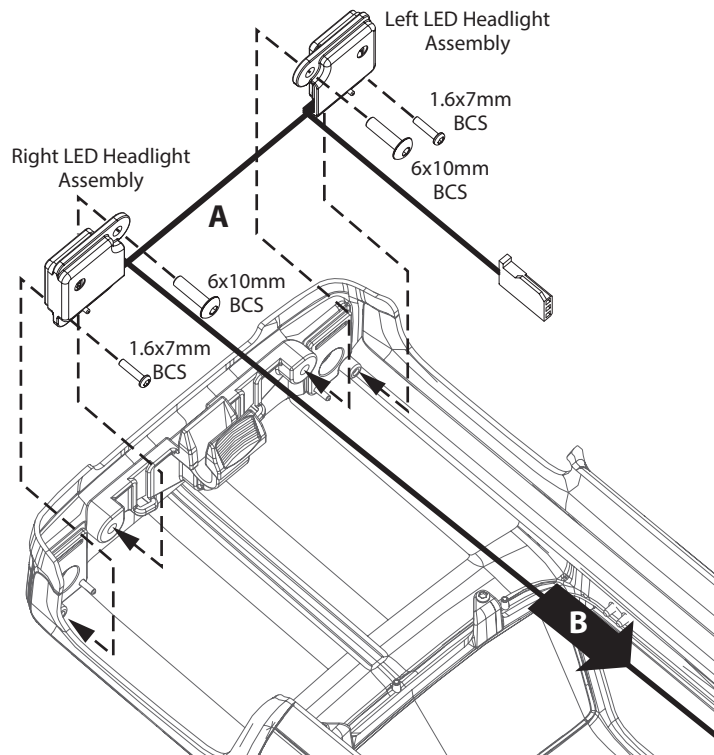

3. Install the right and then left LED tail light assemblies.

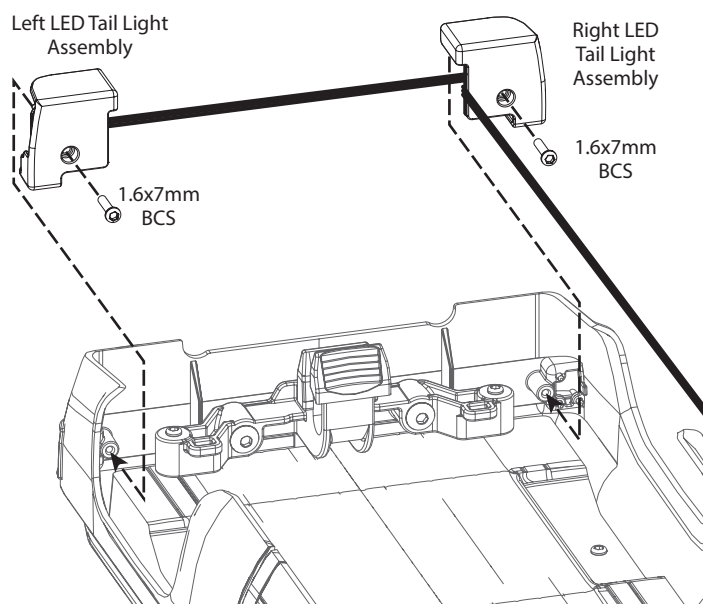

If you have questions or need technical assistance, call Traxxas at

1-888-TRAXXAS

(1-888-872-9927) (U.S. residents only)

TRAXXAS.COM

Traxxas, 6250 Traxxas Way, McKinney, TX 75070, Phone: 972-549-3000, Fax: 972-549-3011, e-mail: support@Traxxas.com

HKC23079-R00 Rev 230810

WIRING DIAGRAM

Use zip ties to secure all wiring to the body in the 5 locations shown.

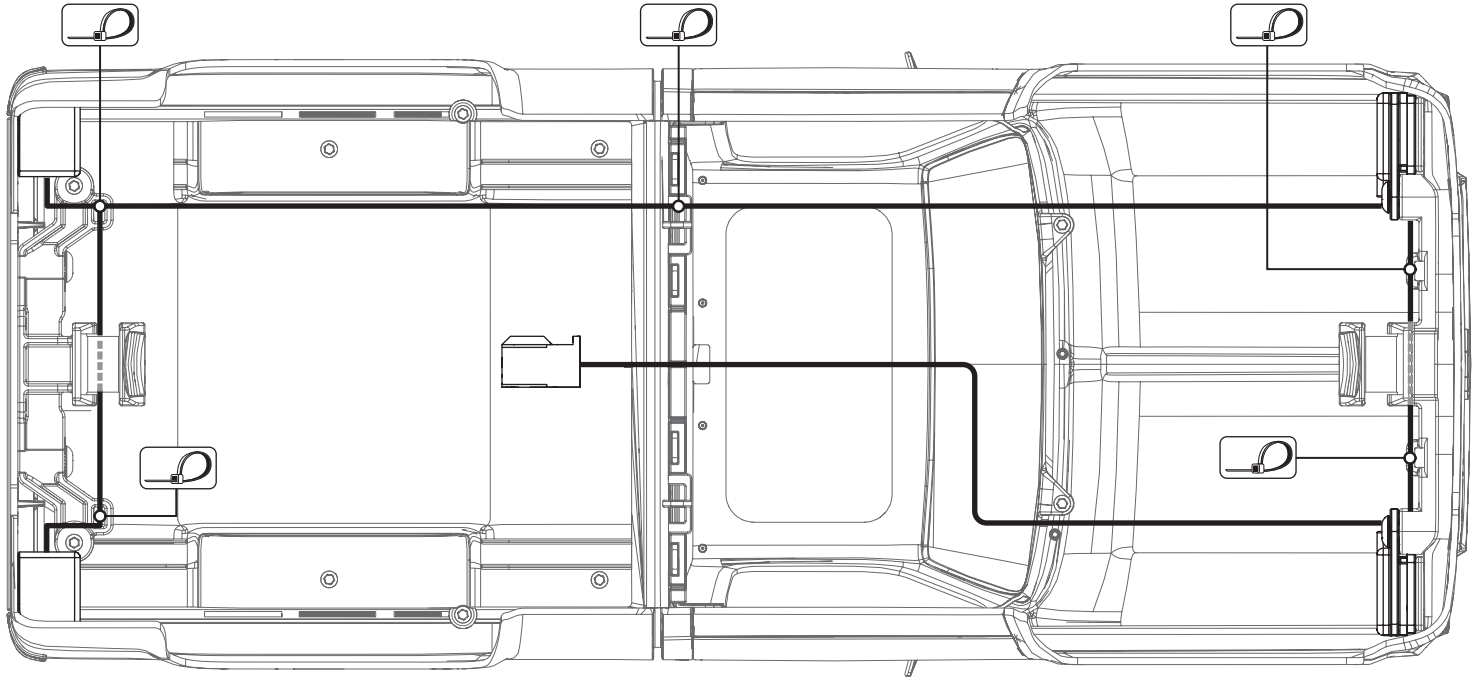

BODY UNDERSIDE VIEW

OPERATION

Mode Selection

The LED lights will turn on when the electronic control module (ECM) is powered on by plugging in the battery. Press and release the **EZ-Set button** on the ECM to toggle through the different lighting modes. The chart below indicates how the lights will function in each mode:

Mode	Selection	Action
1	Headlights, daytime running lights, and tail lights on; brake lights on when braking; reverse lights on when reversing	Default
2	Headlights off; daytime running lights and tail lights on; brake lights on when braking; reverse lights on when reversing	Press and release EZ-Set button on ECM once
3	Headlights, daytime running lights, and tail lights off; brake lights on when braking; reverse lights on when reversing	Press and release EZ-Set button on ECM 2x
4	Hazard lights on; headlights, daytime running lights, and tail lights off; brake lights on when braking; reverse lights on when reversing	Press and release EZ-Set button on ECM 3x
5	LED lights display (demo mode, sequence of all lighting) (truck will not drive in this mode)	Press and release EZ-Set button on ECM 4x

To reset back to the default mode and settings, unplug the battery from the ECM and start over.

WARRANTY

Warranty Information

Traxxas electronic components are warranted to be free from defects in materials and workmanship for a period of 30 days from the date of purchase.

Limitations: Any and all warranty coverage does not cover replacement of parts and components damaged by abuse, neglect, improper or unreasonable use, crash damage, water or excessive moisture, chemical damage, improper or infrequent maintenance, accident, unauthorized alteration or modification or items that are considered consumable. Traxxas will not pay for the cost of shipping or transportation of a defective component to us.

Traxxas Lifetime Electronics Warranty

After the expiration date of the warranty period, Traxxas will repair electronic components for a flat rate. The covered repairs are limited to non-mechanical components that have NOT been subjected to abuse, misuse, or neglect. Products damaged by intentional abuse, misuse, or neglect may be subject to additional charges. Traxxas liability, in no case, shall be greater than the actual purchase price of this product. For replacement, product must be returned in brand new condition, with packaging and itemized sales receipt.