

S-CD500KS

Knuckle servo for drift cars

Instruction Manual

Thank you for purchasing the S-CD500KS drift car steering servo. Before use, be sure to read the online instruction manual and use it correctly and safely.

< S-CD500KS Specifications >

【Size】 32.0 × 16.6 × 27.6 mm	【Torque】
【Weight】 20.7 g	2.4 kgf · cm (6.0 V)
【Speed】	2.0 kgf · cm (4.8 V)
0.130 sec / 60° (6.0 V)	【Rated Voltage】 DC 4.8V~6.0V
0.165 sec / 60° (4.8 V)	

Set Contents

[2 pieces each included in a 2-piece set]

● S-CD500KS

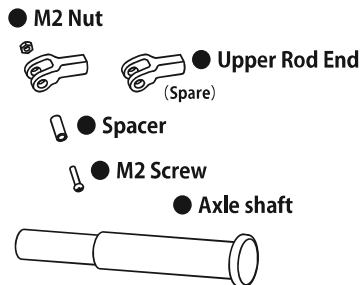

This servo is a steering servo for 1/10 EP 2WD drift cars.

*Two servos are required for one car.

*The latest version of GYD560 is required.

*The latest versions of T10PX(R), T10XCR, and T6PV are required.

The transmitter must have the ability to mix two steering servos.

*Use the ESC's BEC output at 6.0V.

Using the BEC output at 7.4V may cause damage.

*This servo makes a small sound when the power is turned on, but this is not a problem.

Installation example



*Car kit, wheels and tires are not included.

*Wheel hub, wheel hub fixing pin, and bearing (outer diameter 10mm x inner diameter 5mm x thickness 4mm) are not included. Please prepare them separately.

Precautions

- ❗ **Two steering servos are required for one car.**
- ❗ **Use a transmitter that supports two steering servos and a drift car gyro that supports two servos.**
 - This servo requires 2 steering servo mixing.
- ❗ **Prior to installing the servos, be sure to check the travel direction of the output shaft by operating the transmitter/receiver/gyro to be used.**
 - This servo does not have a mechanical rotation limiter. If the servo is installed in the 180-degree opposite direction, an excessive load may damage the servo.
- ❗ **Be sure to apply a thread locking agent to the rod end nut that is attached to the output shaft.**
 - If the screw loosens during operation, the unit will become inoperable.
- ❗ **Always turn on the transmitter first followed by the receiver. In addition, check the operation of all the servos before use every time.**
- ⊘ **Do not insert or remove the servo connector while the receiver power is ON.**
 - Since the S.BUS2 servo switches the operation mode automatically according to the type of signal (S.BUS signal/PWM signal) from the receiver, if the connector is inserted or removed while the power is ON, an S.BUS connected servo will be erroneously recognized and may stop.
- ⊘ **Do not leave the servo in the locked state.**
 - Leaving the servo in the locked state (state in which enough force is applied that the servo cannot move) may cause smoke, fire, and damage.
- ⊘ **Never connect the battery in reverse.**
 - Reverse connection may cause smoke, fire, and damage.
- ⊘ **Do not expose the servo to dust and water.**
 - The servo does not have a waterproof construction. If it gets wet, the servo may not operate or the power supply may short circuit.
- ⊘ **Do not turn the servo with unreasonable force.**
 - The servo may be damaged.
- ⊘ **Do not disassemble or modify the servo.**
 - The servo has a precision construction. Futaba Corp. will not be responsible for any disassembly or modification other than those specified by us.
- ⊘ **Do not drop the servo or expose it to strong shocks or vibrations.**
 - It will damage with a shock.
- ❗ **Use the servo as an actuator in hobby applications.**
 - Futaba will not be responsible if the servo is used in applications other than the above.
- ❗ **Make sure the servo wiring does not touch the wheel.**
 - If the servo wiring comes into contact with the rotating wheel, there is a risk of it breaking and shorting out.
- ❗ **Use the power source as specified and be sure that the battery or a voltage regulator provides an enough margin to sustain the servo operation.**
 - Decide the safe number of uses by paying careful attention to the remaining battery capacity.
- ❗ **Use the ESC's BEC output at 6.0V.**
 - Using the BEC output at 7.4V may cause damage.

Connect the wires as shown in the illustration.

- ❗ **Make sure the servo wiring does not touch the wheel.**
 - If the servo wiring comes into contact with the rotating wheel, there is a risk of it breaking and shorting out.

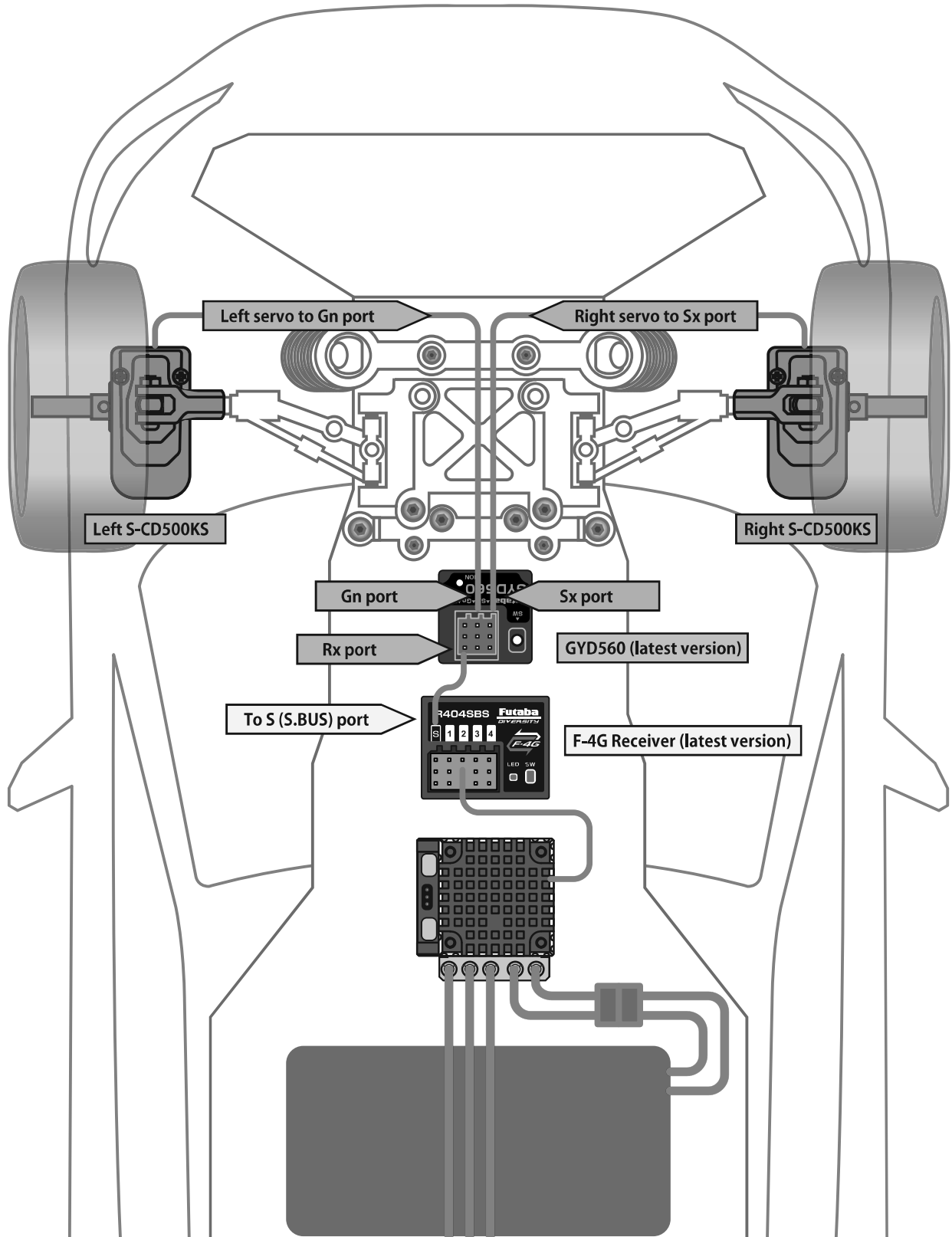

Update the transmitter to a version that supports knuckle servos.

Required for update (Purchase separately)

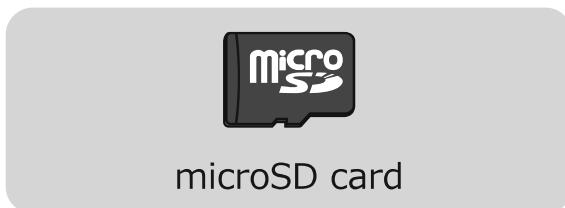
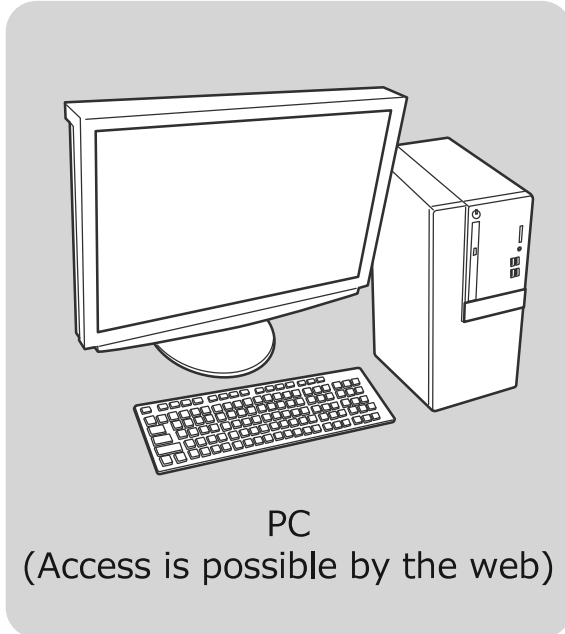

Update Precautions



Do not remove the battery or microSD card during the update, as this may damage the transmitter.

How to recover from a failed update

If the update fails, the transmitter may not start up.

If this happens, update the transmitter again using the following steps.

1. Remove the battery and reinstall it.
2. Insert the microSD card containing the update file into the transmitter.
3. While pressing the home button, turn the power on.
4. Update will begin.

If the transmitter does not start up even after performing the above steps, contact your dealer for repair.

Note: Before you update the software, the battery that is connected to the transmitter should be fully charged.

Note: During the software update, the model data that is stored in the transmitter should be kept without any change. (NOT erased and NOT changed.) However, for your safety, making a backup of your model data before the software update is highly recommended.

Updating procedure

1. Download the zip file of the update data from our website or your local distributor's website.

<https://futabausa.com/>

2. Extract the zip file on your computer.

3. Insert the micro SD card into the PC and copy the FUTABA folder expanded on the PC to the micro SD card.

If you already have a microSD card FUTABA folder, overwrite it.



FUTABA

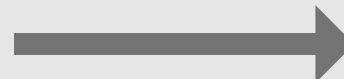

- 4. Insert the micro SD card with the copied FUTABA folder into the transmitter.**

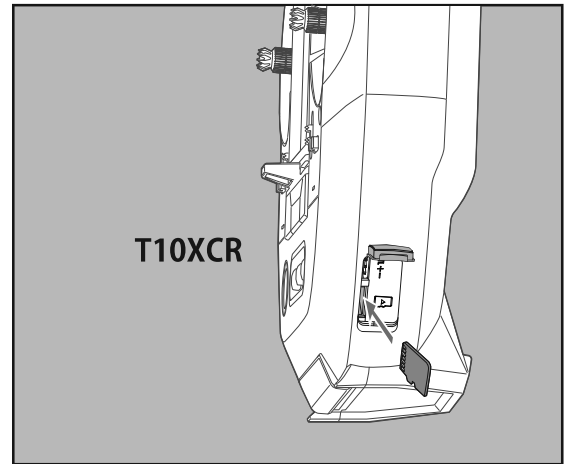
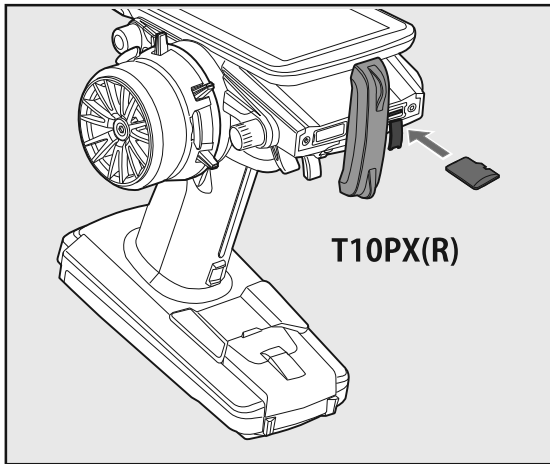

- 5. Turn on the transmitter power while pressing down the "HOME" button. The update screen appears on the LCD display of your transmitter and the software update is started.**

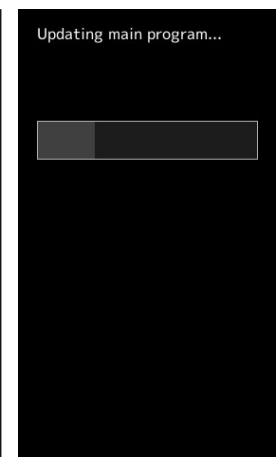
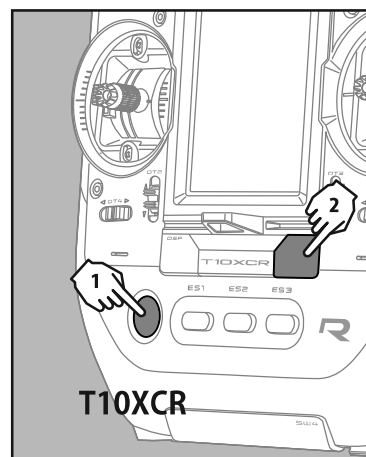
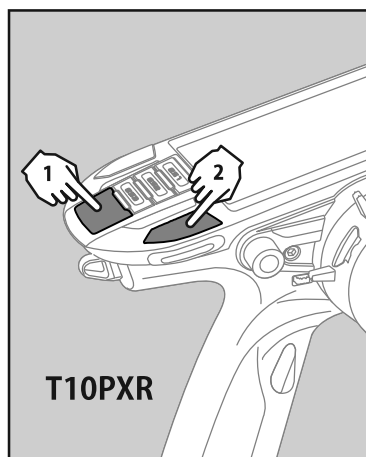
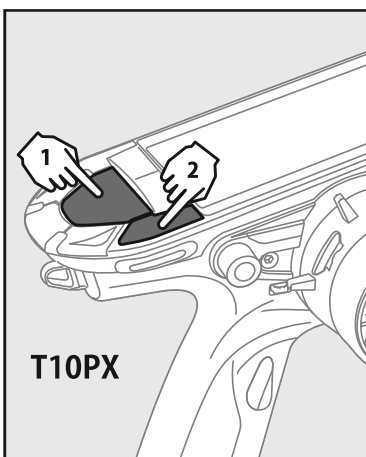

- 6. When the software update is completed, "Completed" message is shown on the LCD display of your transmitter. (Show below picture.)**

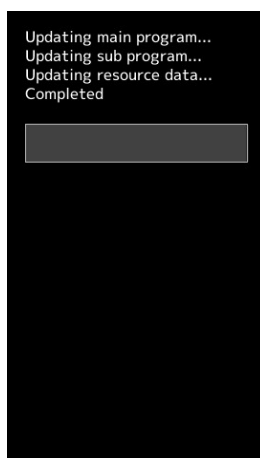

Possible Problems

When one of the error messages shown below appears on the LCD screen your transmitter, the software update will not be completed.

"Low battery."

Software update is postponed because of low battery. Retry the software update after the battery is recharged.

"Update file not found."

The transmitter cannot find the update file on the microSD card. Check to be sure all the update files have been copied onto the microSD card.

"Broken file."

The transmitter detects the update file error. The update file may be broken or for another transmitter.

"Write error."

The software update procedure is stopped for an unknown reason. Contact your local service center when this error message appears on the LCD screen of your transmitter.

- 7. Turn off the power of transmitter.**

Updates the GYD560 to a knuckle servo compatible version.

Required for update

T10PX (R)

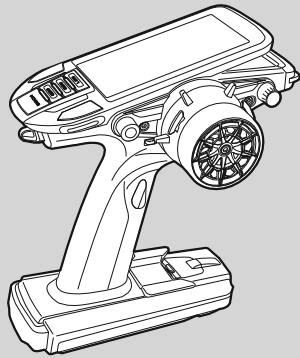

T10XCR

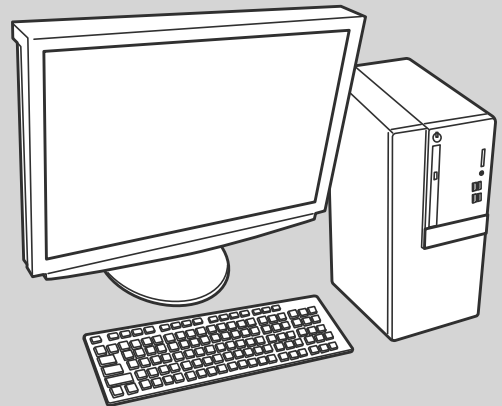
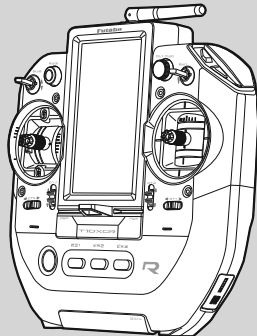

PC

(Access is possible by the web)



Receiver connection cord
(GYD560 Included)



microSD

Update Procedure

1. Download the zip file of the DLPH-2 update data from our website or your local distributor's website.

<https://www.rc.futaba.co.jp/>

<https://futabausa.com>



2. Extract the zip file on your computer.

3. Copy the "FUTABA" folder into your microSD card.



4. Insert the microSD card with "FUTABA" folder that contained the update software into the SD card slot on your transmitter.

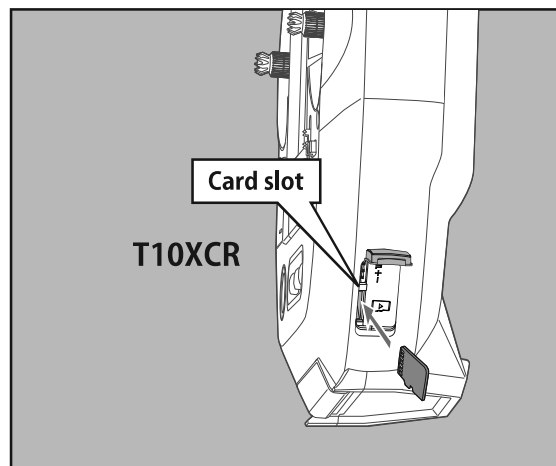
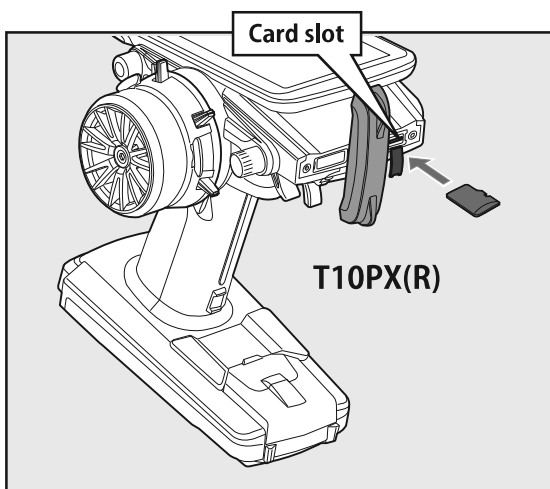

5. Connect the GYD560 to be updated to the Communication Port of the transmitter.

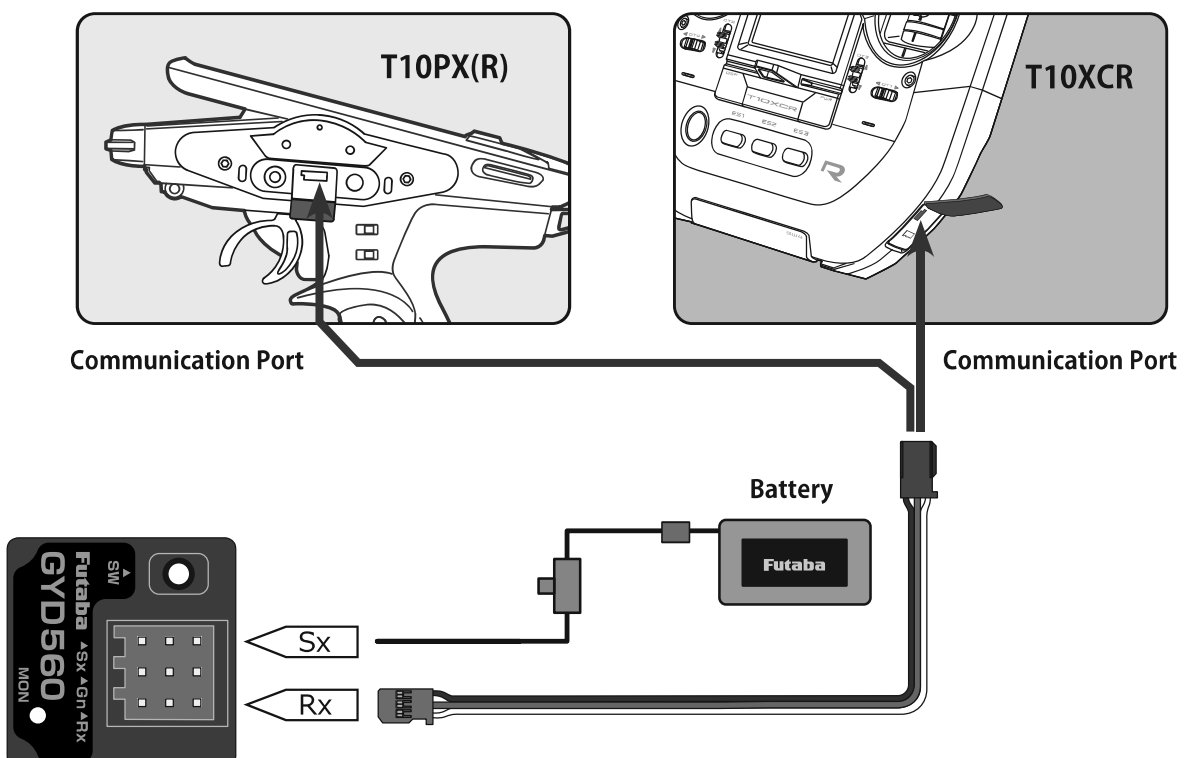

6. Turn on the transmitter and call "System Menu" ⇒ "Update" ⇒ "Gyro update" ⇒ "GYD560".

*T10PX(R) and T10XCR also need to be updated to the latest version.

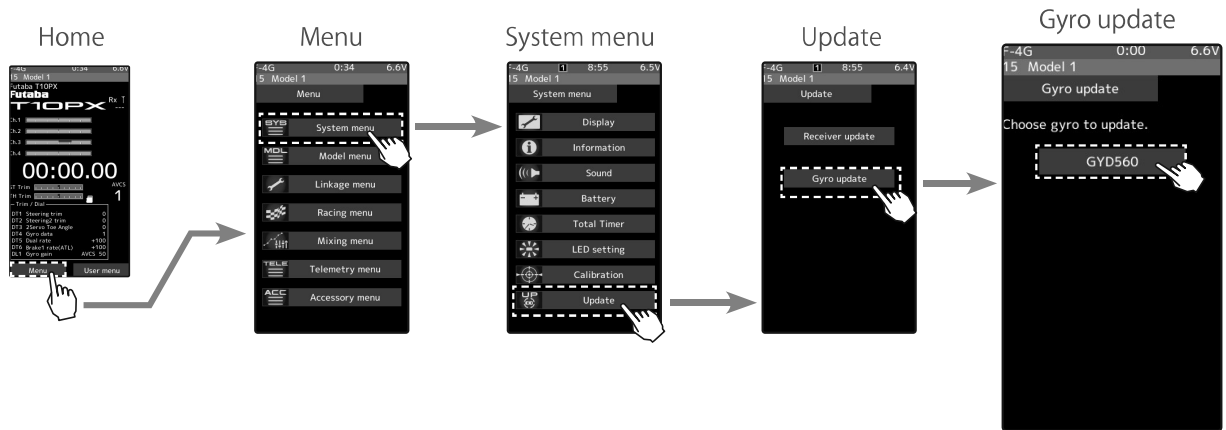

7. Put the gyro ready for update. (Transmitter is ON and the gyro update screen remains)

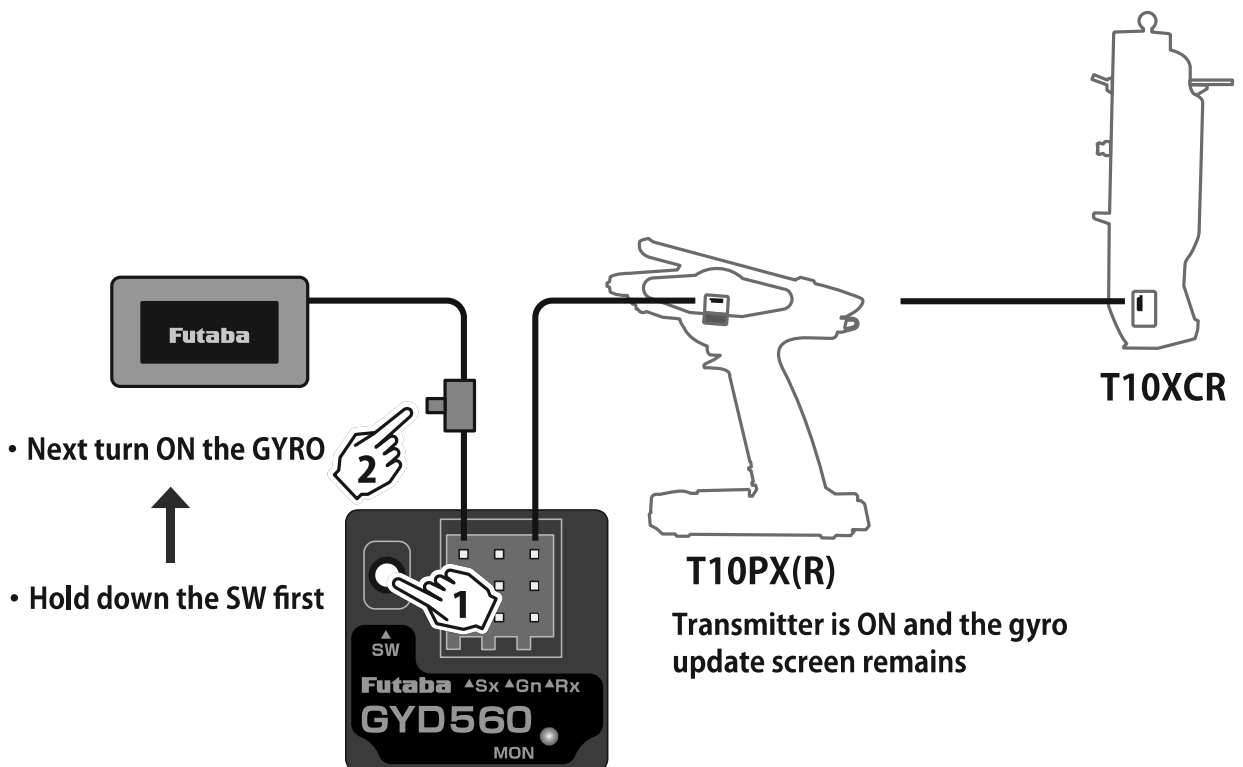

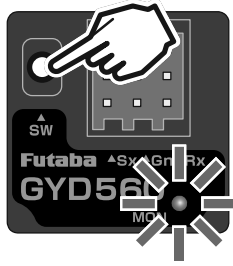

- Keep pressing SW

- LED Red light

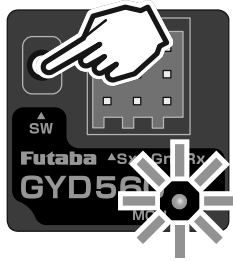

- After 3 seconds
LED Orange light

- Continue holding it for approximately
another 10 seconds

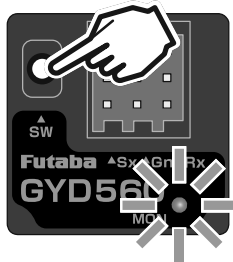

- Green light will flash briefly

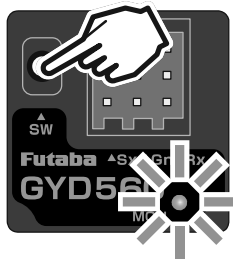

- It will return to Orange light

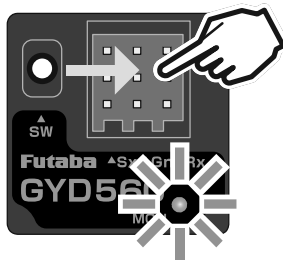

- Release the SW

- Orange light

Update ready

If the mode LED lights up Orange, it has failed. Please retry.

8. Tap [Update]

The update will begin. A progress bar will appear to indicate the progress. The gyro LED will light up green and flash green briefly each time data is received from the transmitter.

***Do not turn off the transmitter power while updating.**

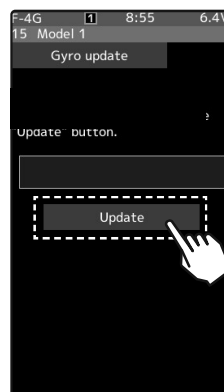

9. When the update is complete, a message will be displayed and the gyro LED will remain lit green. Turn off the gyro power.

Before using, check that it is operating properly.

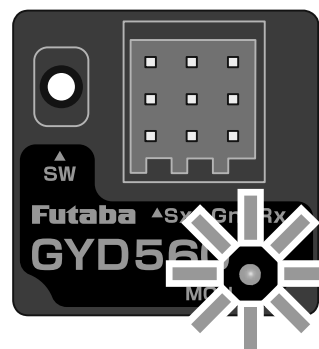

10. Disconnect the Gyro from the transmitter's Communication Port.

11. When finished, press and hold the home button on the transmitter to return to the home screen.

Error

If an error display appeared, reinstall the update from the beginning.

- The gyro is not in the update wait state.
- The cable is disconnected.
- The power has been turned off
- The micro SD card is not inserted in the transmitter.
- There is no data on micro SD card.

Installation Method

1. Remove the conventional steering servo and steering linkage parts mounted on the chassis.

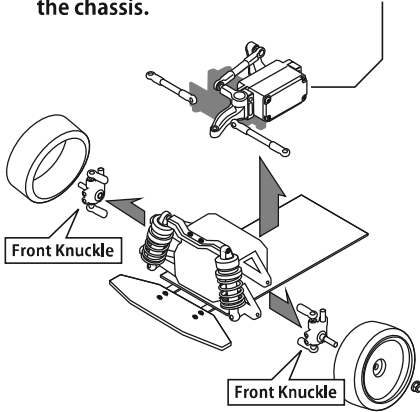

2. Remove the left and right front knuckles.

3. Insert two outer 10mm x inner 5mm ball bearings into the knuckle servo.

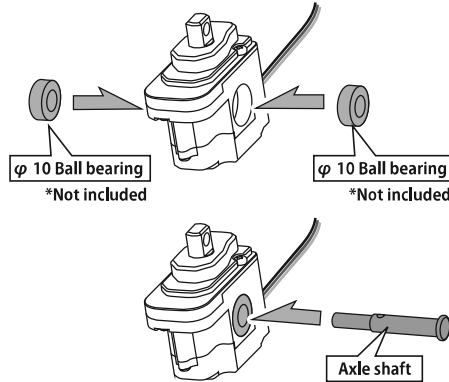

4. Insert the Axle shaft into the left and right knuckle servos.

5. Insert the wheel hub pin and hexagonal hub into the Axle shaft.

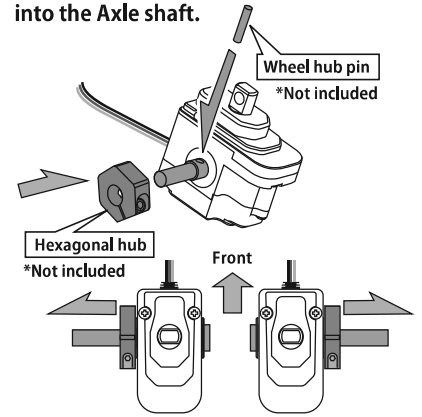

- ! The axle shafts of the left and right servos are inserted in opposite directions.

6. Attach the upper rod end to the upper arm of the front suspension.

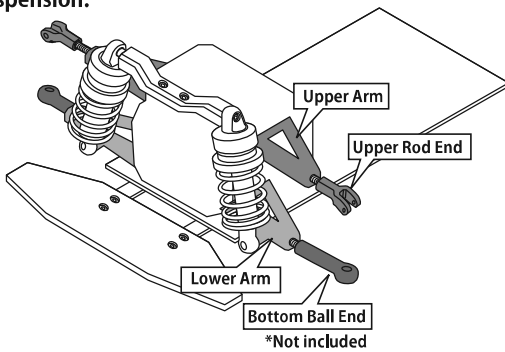

7. The bottom ball end of the lower arm uses the same part as before.

8. Attach the conventional ball link part to the bottom of the knuckle servo.

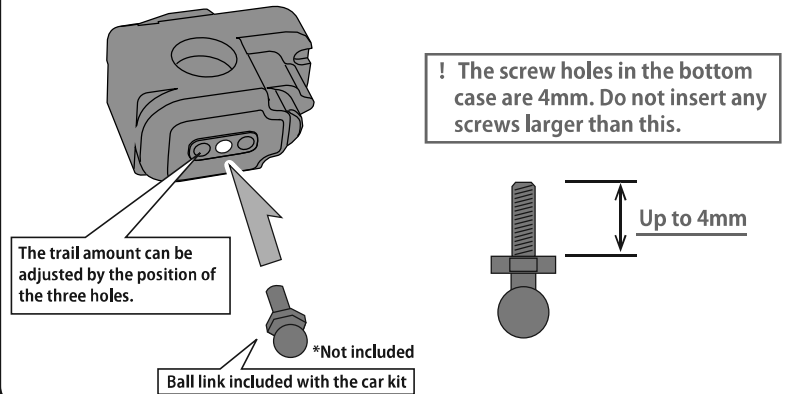

9. Be sure to turn on the power to the transmitter/receiver and knuckle servo and check that they are in neutral before installing them.

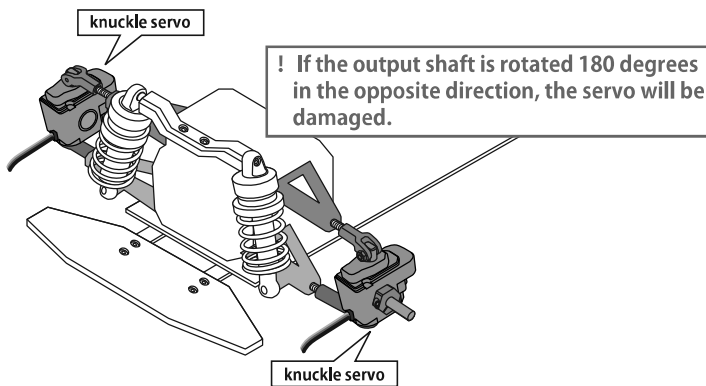

10. Attach the left and right knuckle servo output shafts with M2 screws, collars, and M2 nut

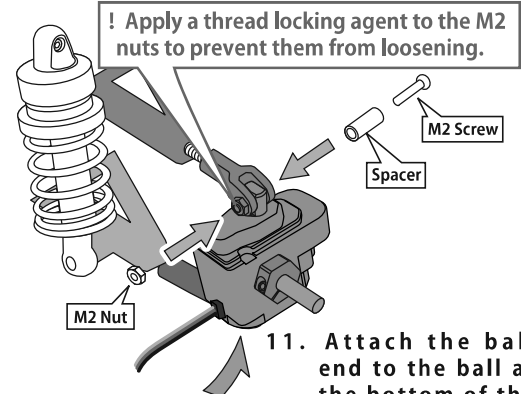

11. Attach the ball end to the ball at the bottom of the knuckle servo.

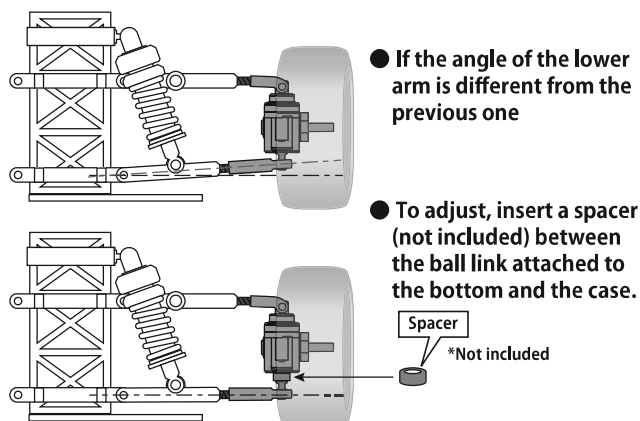

12. Install the front wheel.

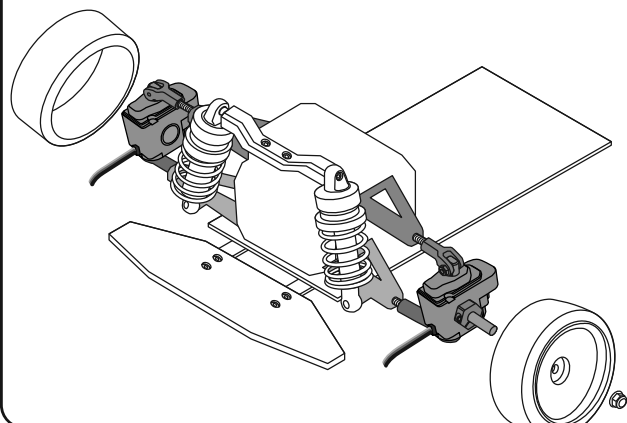

Steering Alignment

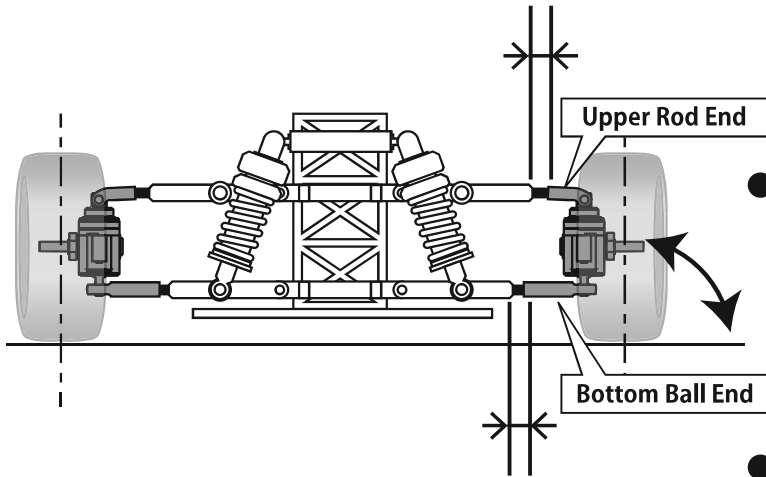

● Camber angle and wheel width is adjusted by changing the length of the upper rod end and the bottom ball end.

● Toe angle and Ackermann can be easily set using the transmitter.

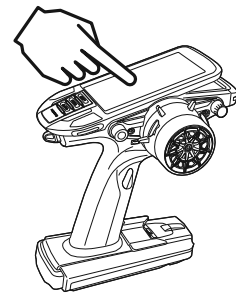
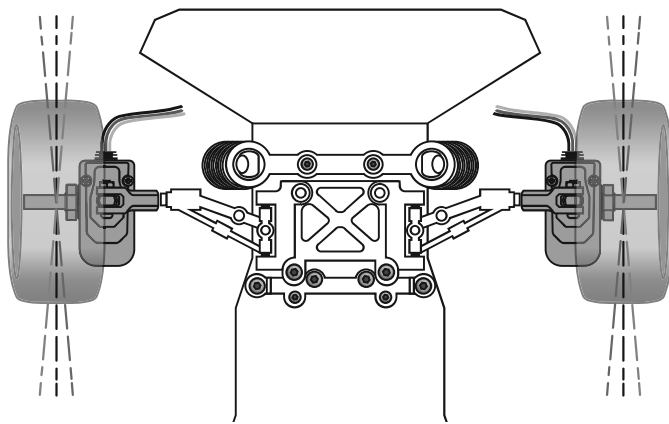

*Update transmitter and gyro to the latest version.

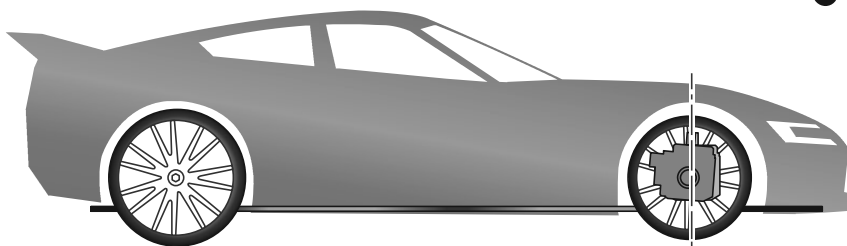

Trail direction plus

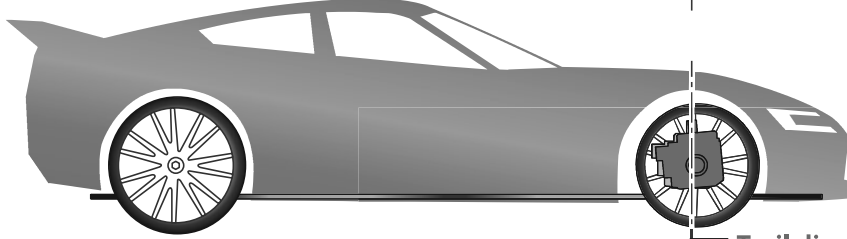
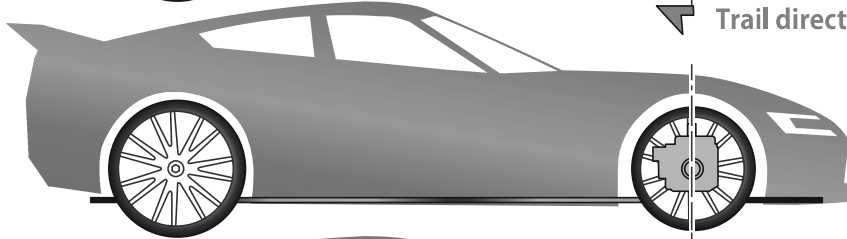

Trail direction minus



● T10PX(R),T10XCR Setting

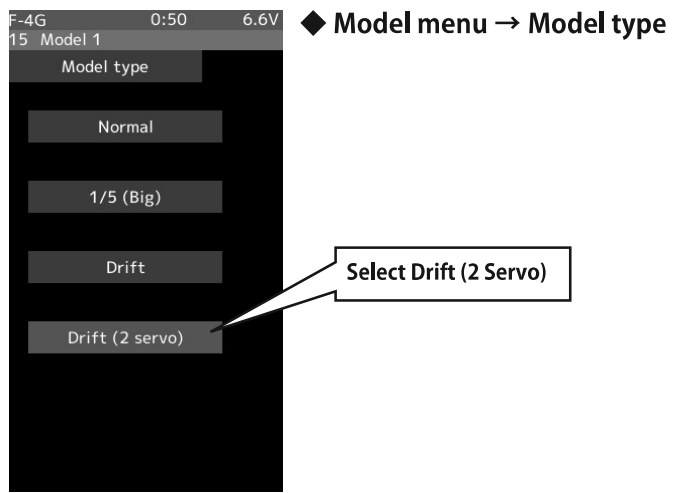

● Knuckle servo mixing settings

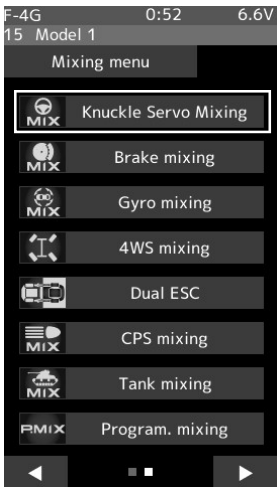

The following mixing can be set here:
 1/2: Mixing from brake operation to steering
 2/2: Mixing from accelerator operation to steering

Toe : A mode in which the amount of steering servo movement changes depending on the brake operation, regardless of steering operation.
Steer : A mode in which the amount of steering servo movement changes according to the steering direction when braking.

1/2 Brake to steering mixing settings

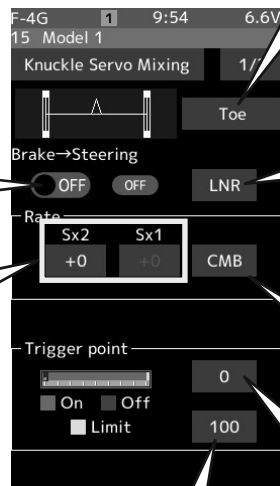

Mixing ON/OFF

Mixing rate setting
 In CMB mode, the same rate is set for both left and right. In SEP mode, the rate can be set independently for both left and right.

LNR (Linear) : Mode in which the mixing amount changes according to brake operation.
OFS (Offset) : A fixed offset is added.

CMB (Combination Mode) : Mode to set the mixing amount of the left and right servos simultaneously.
SEP (Separate Mode) : A mode in which the mixing amount for the left and right servos can be set individually.

Set the trigger position at which mixing turns ON
 0% → Neutral position
 100% → Maximum brake position

Sets the point at which the mixing amount stops increasing in LNR mode.
 The mixing amount will not increase beyond this trigger position.

2/2 Throttle to steering mixing settings

Toe : A mode in which the amount of steering servo movement changes depending on the throttle operation, regardless of steering operation.
Steer : A mode in which the amount of steering servo movement changes according to the steering direction when throttle operation.

LNR (Linear) : Mode in which the mixing amount changes according to throttle operation.
OFS (Offset) : A fixed offset is added.

CMB (Combination Mode) : Mode to set the mixing amount of the left and right servos simultaneously.
SEP (Separate Mode) : A mode in which the mixing amount for the left and right servos can be set individually.

Set the trigger position at which mixing turns ON
0% → Neutral position
100% → Maximum brake position

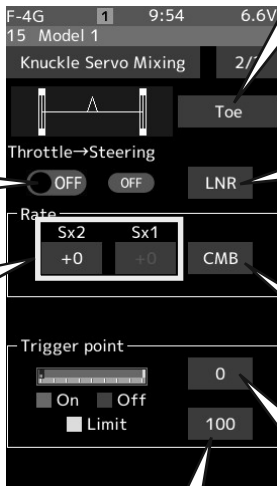

Mixing ON/OFF

Mixing rate setting
In CMB mode, the same rate is set for both left and right. In SEP mode, the rate can be set independently for both left and right.

Sets the point at which the mixing amount stops increasing in LNR mode.
The mixing amount will not increase beyond this trigger position.

● GYD560 Setting

◆ Accessory menu → Gyro link



To setting the gyro, select Gyro link.

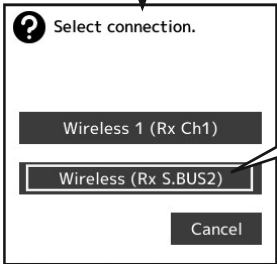

Select this when using a knuckle servo.

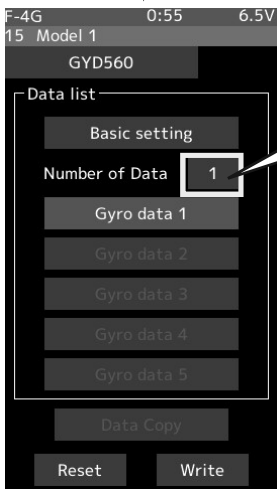

Set the number of gyro data to use.

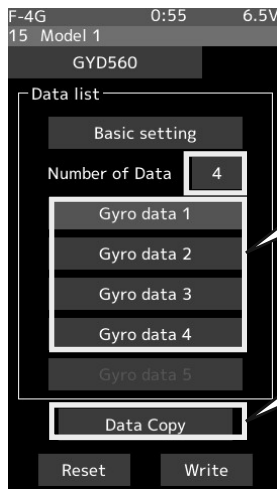

The setting button will be enabled according to the number of data you have set.

The copy function is useful when there are multiple pieces of data.

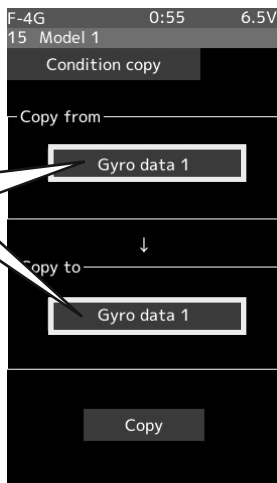

Set the copy source and copy destination.

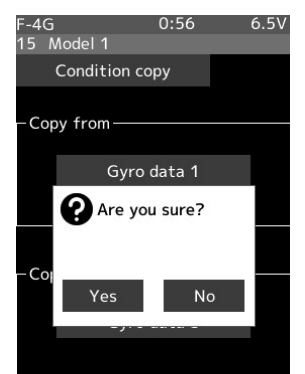
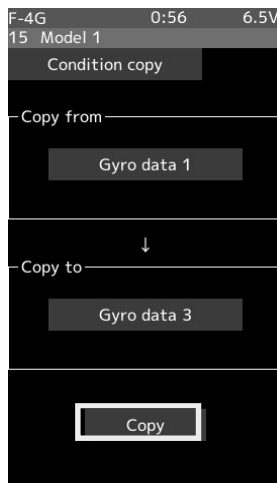

Touch [Yes] to execute the copy.
Touch [No] to cancel.

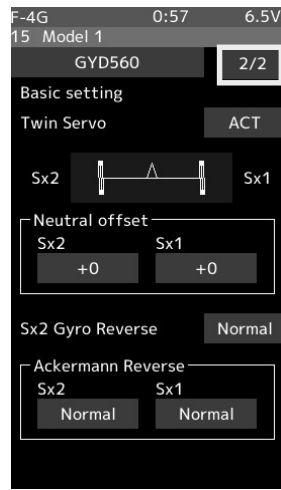
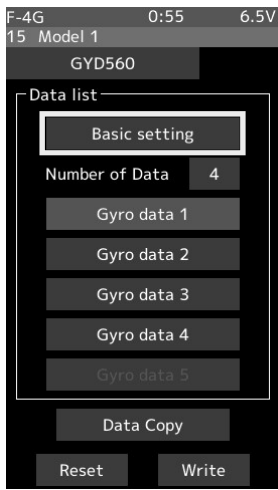

ACT: Knuckle servo
INH: Conventional single servo

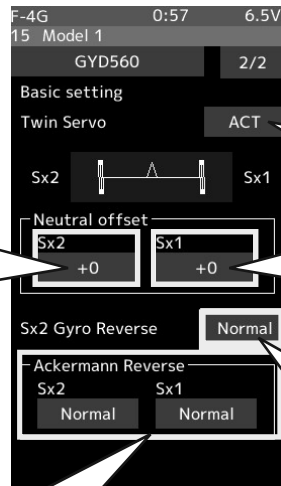

When [ACT] is selected, the setting items for the 2nd servo are displayed. Change this setting, power cycle the gyro. The function will be enabled after rebooting.

Neutral adjustment of 2nd servo (Sx2)

Neutral adjustment of 1st servo (Sx1)

This sets the gyro direction for the 2nd servo (Sx2). The gyro direction for the 1st servo (Sx1) is set in Reverse on page 1/2.

Sets the direction of movement for Rate A and Rate B of the Ackermann rate in the gyro data settings. Normally, use Normal.

● Gyro Link

Page 1/4

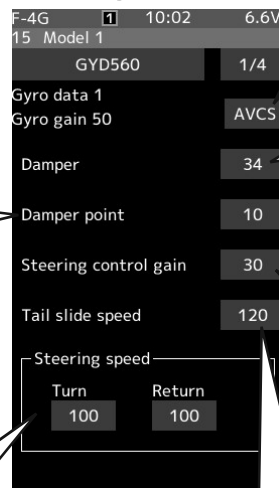

Setting data for AVCS and normal can be set separately. Use this button to switch between AVCS and normal.

Damper point
Adjust the servo response due to the effect of the damper against the gyro effect.
* The smaller the value, the stronger the influence of the Damper and the slower the servo speed.
* The higher the value, the slower the Damper will operate and the better the response, but the more likely it is that hunting will occur.

Damper
Hunting suppression
The higher the value, the stronger the hunting suppression. However, it will feel like the servo response has worsened.

Steering control gain
Adjustment of intervention ratio of steering operation to gyro control.
When the numerical value is increased, the steering operation of the driver is largely reflected.
* The steering response feels fast.

Steering speed
The function to adjust servo speed for steering operation (same the function as servo speed of the transmitter).
* The smaller the value, the slower the servo speed.

Tail slide speed
Adjust the speed of the tail slide (shake the tail) when driving.
* Decreasing the numerical value decreases the speed of the tail slide, and increasing the numerical value increases the speed.
* Effective for adjusting the tail slide amount during steering operation.

Page 2/4

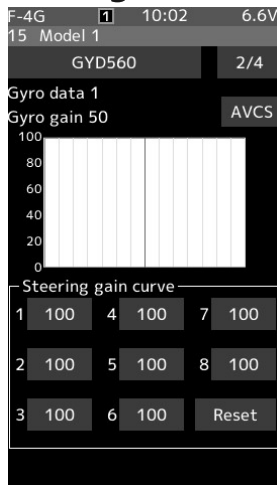

Setting data for AVCS and normal can be set separately. Use this button to switch between AVCS and normal.

Steering gain curve

Eight points of gain can be set up to the endpoint based on neutral.

* It is set in conjunction with left-right symmetry.

Page 3/4

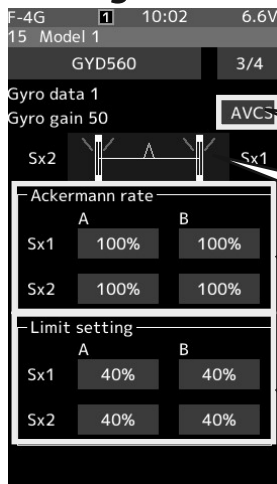

Setting data for AVCS and normal can be set separately. Use this button to switch between AVCS and normal.

The red line reflects the limit setting.

Ackermann movement can be set by creating a difference between the movement amounts of Rate A and Rate B.

Set the maximum movement amount of the 1st and 2nd servos. This can be set for each gyro data.

Page 4/4

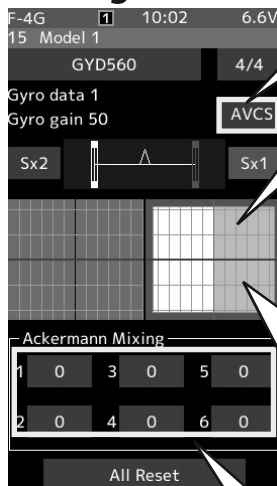

Setting data for AVCS and normal can be set separately. Use this button to switch between AVCS and normal.

12-point curve can be added to the Ackermann movement. The final movement amount is determined by the rate value obtained by adding the rate from the curve and the Ackermann rate on page 3/4.

Tapping the graph will switch the servo being set between Sx1 and Sx2. The background color of the graph in the direction of the setting point will be shown in white. Operating the steering wheel will switch the direction of the setting target and change the background color of the graph.

Turning the steering wheel will switch the curve setting target between right and left rotation.

(The setting point on the white side of the graph background is displayed.)